

MetPurl[®]



PURLINS & RAILS

TECHNICAL MANUAL



Construction Metal Forming

Version 1.4 | 02/23



Construction Metal Forming Limited (CMF) was established in 2005, operating out of a state-of-the-art manufacturing facility located in South Wales.



The facility was designed to include three dedicated production lines for the manufacture of **MetFloor** metal decking. Due to its success, **CMF** expanded in 2015 by adding the UK's only Shear Stud manufacturing production line, leading to the development of the **Composite Shear Connector (CSC)**.

In addition, **CMF** procured a fully CNC roll forming line which has a capacity to roll sections up to 500mm deep and in gauges from 1.2 to 3.5mm thick. This allowed **CMF** to develop the **MetPurl** purlin system which offers the largest range available in the UK. The **MetPurl** system has been fully tested by the Building Research establishment (BRE) and ratified by the Steel Construction Institute (SCI).

In recent years, **CMF** has undergone significant expansion and investment including a second manufacturing facility, specifically for our **MetPurl** product range. This allows for increased production capacity and improved efficiency. Additionally, the company has purchased another state-of-the-art roll forming Bradbury line, along with a Samesor line, designed for smaller / lighter sections.

With this investment, **CMF** can now produce a range from 0.7mm up to 4.0mm thus bolstering the variety of sections on offer. **CMF** has enhanced its product offerings and improved its manufacturing capabilities, positioning the company as a leader in the metal forming industry.

CMF offer a fully comprehensive Z and C section Purlin and Side Rail system.

Our purlins and side rails have been fully tested at the Building Research Establishment (BRE) and ratified by the Steel Construction Institute (SCI). Industry Members of the British Construction Steel Association (BCSA).



Introduction	02	Side Rail Systems	44
Component Overview	06	Vertical Cladding Restraint Layouts	46
Component Dimensions and Properties	08	Side Rail Support & Tie Wire Details	47
Z-Section Dimensions & Properties	08	Typical Layouts Horizontal Cladding	48
Z-Section Purlins / Side Rails	10	Column Joint Rail (CoJR)	49
C-Section Dimensions & Properties	12	Cladding Support Rail (CSR)	50
C-Section Side Rails	14	Cladding Joint Rail (CJR)	51
Wide Flange Z-Section Dimensions & Properties	16	Window Trimmers, Door Posts & Brick Channels	52
Wide Flange C-Section Dimensions & Properties	17	MetPurl Design Software	53
Flat Back Eaves Beam Dimensions & Properties	18	Case Study	54
Sigma Eaves Beam Dimensions & Properties	20	Load Span Tables	55
System Layouts – Purlins and Rails	22	Load Span Tables – Z-Sections	56
Z & C Purlin & Side Rail System Layouts	22	Single Span Butted	56
Butted Purlin & Rail System	23	Double Span Butted	58
Sleeved Purlin & Rail System	24	Single/Double Span Sleeved	60
Cleats	26	Heavy End Bay Single/Double Span – End Bay	62
Bolt On Cleats	26	Heavy End Bay Single Span – Inner Bay	64
Weld On Cleats	27	Heavy End Bay Double Span – Inner Bay	66
Profiled Cleats	28	Load Span Tables – C-Sections	68
Case Study	29	Single Span Butted	68
Purlin Systems	30	Double Span Butted	70
Purlin Systems	30	Side Rail System – Single/Double Span Sleeved	72
Anti Sag & Strutting Requirements	32	Side Rail System – Heavy End Bay Single Span	74
Apex Tying	33	Case Study	75
Rafters/ Column stays	34	Appendix A	
Roof Slopes	35	Example Component Drawings	77
Barrel Roof	36	CMF Purlin / Rails	78
Cantilevers	37	CMF Sleeves	82
Cleaver Rails	38	CMF Cleats	86
Cladding Restraint	39	CMF Accessories	98
Tiled Roofs	40		
Eaves Beams	41		
Eaves Beam Details	42		
Gutter Details	43		



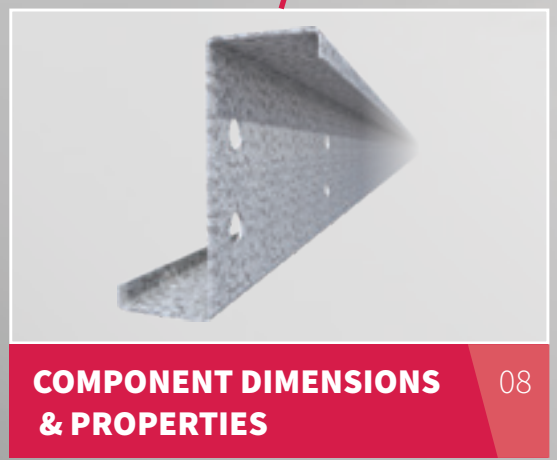
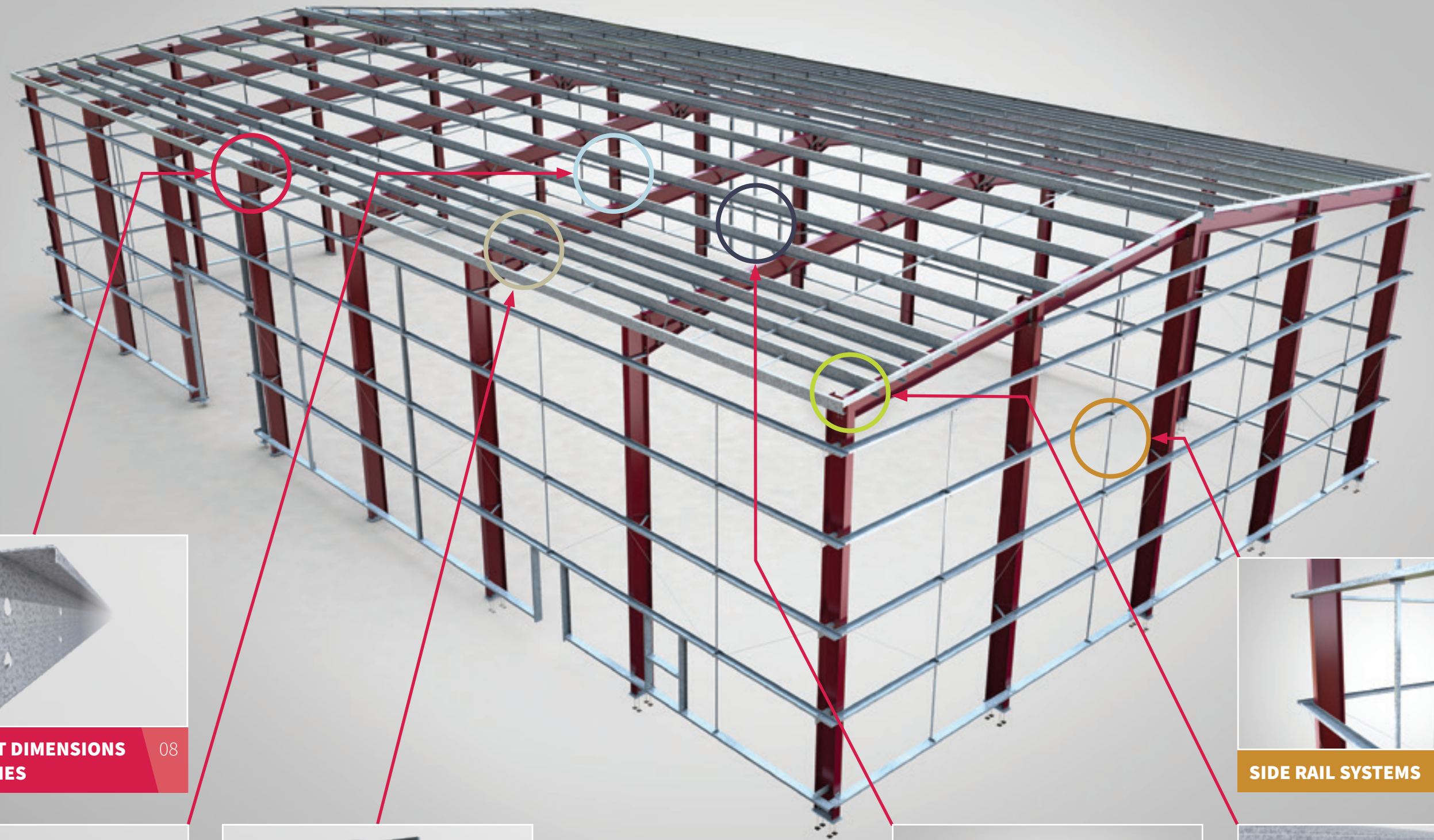

COMPONENT DIMENSIONS & PROPERTIES 08

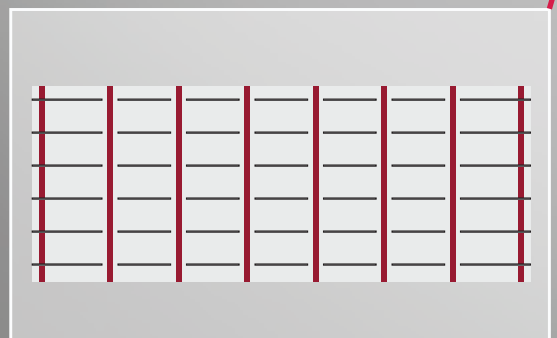

SYSTEM LAYOUTS 22



CLEATS 26



PURLIN SYSTEMS 30



SIDE RAIL SYSTEMS 44

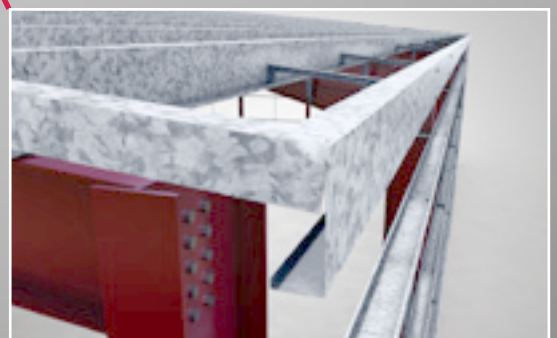

EAVES BEAMS 41

Z-SECTION DIMENSIONS & PROPERTIES

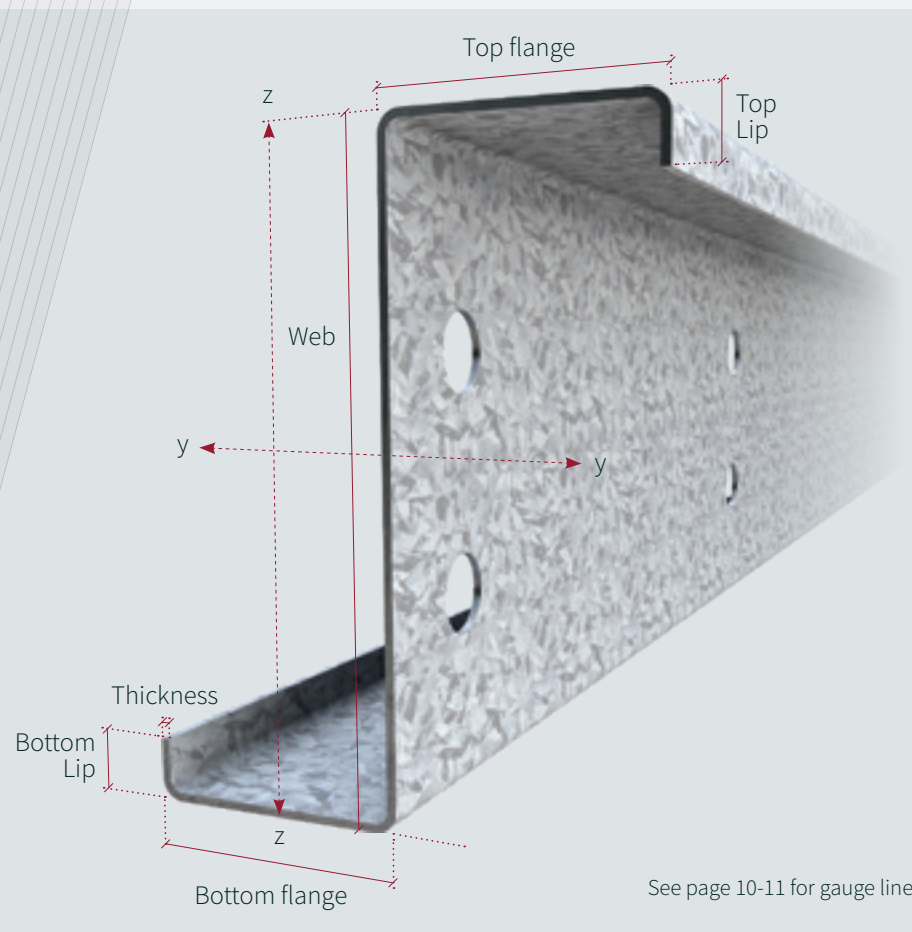

Our Zed profiles are fully symmetrical profiles with both flanges being the same dimension. The Z in the reference **Z12315** refers to the profile shape; the next three digits are the section depth, ie. 123 = 123mm deep; the final two digits equate to the section thickness, so 15 = 1.5mm thickness.

Material
All our sections are cold-formed from hot dipped Z275 galvanized S450GD steel to BS EN 10346:2015 and BS EN 10143:2006, with a minimum yield strength of 450N/mm². Z275 provides an average coating of 20 microns each side. Please contact CMF for advice on other coatings such as Magnelis / Z600.

Sleeves
The complimenting sleeves to suit our Zed range are asymmetric to allow a snug fit and maximum support. The letter references identify the type of sleeves required, ie. **ZS14314** - **ZS** = Standard Sleeve; **ZHS20315** - **ZHS** = Zed Heavy End Bay Sleeve. The number references match those of the above sections.

Section Reference	Section thickness (mm)	Top flange width (mm)	Bottom flange width (mm)	Web depth (mm)	Top lip length (mm)	Bottom lip length (mm)	Weight (kg/m)
Z12315	1.50	50	50	123	14	14	2.79
Z12316	1.60	50	50	123	14	14	2.96
Z14313	1.30	58	58	143	14	14	2.79
Z14314	1.40	58	58	143	14	14	3.00
Z14315	1.50	58	58	143	14	14	3.21
Z14316	1.60	58	58	143	14	14	3.42
Z14318	1.80	58	58	143	14	14	3.83
Z14320	2.00	58	58	143	14	14	4.23
Z17313	1.30	63	63	173	14	14	3.20
Z17314	1.40	63	63	173	14	14	3.44
Z17315	1.50	63	63	173	14	14	3.68
Z17316	1.60	63	63	173	14	14	3.92
Z17318	1.80	63	63	173	14	14	4.39
Z17320	2.00	63	63	173	14	14	4.86
Z17323	2.30	63	63	173	14	14	5.56
Z17325	2.50	63	63	173	14	14	6.01

I_y (cm ⁴)	I_z (cm ⁴)	i_y (cm)	i_z (cm)	$W_{eff,y}$ (cm ³)	$W_{eff,z}$ (cm ³)	W_{ely} (cm ³)
87.8	19.5	4.81	2.34	13.04	4.03	13.61
93.3	20.7	4.81	2.33	14.13	4.28	14.47
119.2	25.6	5.63	2.68	12.91	4.50	15.97
127.9	27.4	5.62	2.67	14.54	4.84	17.15
136.7	29.2	5.62	2.66	16.24	5.16	18.33
145.3	30.9	5.61	2.66	18.00	5.48	19.51
162.5	34.3	5.60	2.65	21.12	6.11	21.83
179.4	37.7	5.60	2.63	24.06	6.73	24.14
194.9	32.1	6.75	2.80	16.16	5.11	21.70
209.3	34.4	6.74	2.79	18.22	5.58	23.31
223.7	36.6	6.74	2.79	20.37	5.95	24.92
237.9	38.8	6.73	2.78	22.59	6.32	26.53
266.2	43.2	6.72	2.77	27.25	7.05	29.71
294.2	47.4	6.71	2.76	32.03	7.77	32.87
335.6	53.5	6.70	2.74	37.56	8.82	37.55
362.9	57.5	6.69	2.73	40.64	9.51	40.64

Section Reference	Section thickness (mm)	Top flange width (mm)	Bottom flange width (mm)	Web depth (mm)	Top lip length (mm)	Bottom lip length (mm)	Weight (kg/m)
Z20313	1.30	63	63	203	14	14	3.51
Z20314	1.40	63	63	203	14	14	3.77
Z20315	1.50	63	63	203	14	14	4.04
Z20316	1.60	63	63	203	14	14	4.30
Z20318	1.80	63	63	203	14	14	4.82
Z20320	2.00	63	63	203	14	14	5.33
Z20323	2.30	63	63	203	14	14	6.10
Z20325	2.50	63	63	203	14	14	6.60
Z20327	2.70	63	63	203	14	14	7.10
Z23314	1.40	63	63	233	14	14	4.10
Z23315	1.50	63	63	233	14	14	4.39
Z23316	1.60	63	63	233	14	14	4.67
Z23318	1.80	63	63	233	14	14	5.24
Z23320	2.00	63	63	233	14	14	5.80
Z23323	2.30	63	63	233	14	14	6.64
Z23325	2.50	63	63	233	14	14	7.19
Z23327	2.70	63	63	233	14	14	7.74
Z26316	1.60	63	63	263	14	14	5.05
Z26318	1.80	63	63	263	14	14	5.66
Z26320	2.00	63	63	263	14	14	6.27
Z26323	2.30	63	63	263	14	14	7.18
Z26325	2.50	63	63	263	14	14	7.78
Z26330	3.00	63	63	263	14	14	9.27
Z30318	1.80	75	75	303	20	20	6.74
Z30320	2.00	75	75	303	20	20	7.47
Z30323	2.30	75	75	303	20	20	8.56
Z30325	2.50	75	75	303	20	20	9.28
Z30330	3.00	75	75	303	20	20	11.06
Z35318	1.80	100	100	353	25	25	8.30
Z35320	2.00	100	100	353	25	25	9.20
Z35323	2.30	100	100	353	25	25	10.54
Z35325	2.50	100	100	353	25	25	11.44
Z35330	3.00	100	100	353	25	25	13.65
Z40320	2.00	100	100	403	30	30	10.14
Z40323	2.30	100	100	403	30	30	11.63
Z40325	2.50	100	100	403	30	30	12.62
Z40330	3.00	100	100	403	30	30	15.07
Z40332	3.20	100	100	403	30	30	16.04

I_y (cm ⁴)	I_z (cm ⁴)	i_y (cm)	i_z (cm)	$W_{eff,y}$ (cm ³)	$W_{eff,z}$ (cm ³)	W_{ely} (cm ³)
282.9	32.2	7.78	2.68	19.21	5.13	26.92
303.9	34.5	7.78	2.68	21.67	5.60	28.93
324.8	36.7	7.77	2.67	24.22	5.98	30.93
345.6	39.0	7.77	2.66	26.86	6.35	32.93
386.9	43.3	7.76	2.65	32.37	7.08	36.90
427.8	47.6	7.75	2.64	38.18	7.80	40.83
488.4	53.8	7.73	2.62	46.67	8.86	46.67
528.2	57.8	7.72	2.61	50.52	9.55	50.52
567.6	61.7	7.71	2.60	54.34	10.23	54.34
420.6	34.6	8.79	2.57	25.15	5.62	34.98
449.7	36.9	8.79	2.56	28.11	6.00	37.40
478.6	39.1	8.78	2.56	31.17	6.37	39.82
535.9	43.5	8.77	2.55	37.57	7.11	44.63
592.8	47.8	8.76	2.53	44.30	7.83	49.40
677.1	54.0	8.74	2.52	54.21	8.89	56.49
732.6	58.0	8.73	2.50	60.21	9.59	61.17
787.6	61.9	8.72	2.49	65.81	10.27	65.81
638.9	39.2	9.77	2.46	35.54	6.39	47.20
715.7	43.6	9.76	2.45	42.83	7.13	52.91
791.9	47.9	9.75	2.44	50.49	7.85	58.58
904.9	54.1	9.73	2.42	61.79	8.92	67.01
979.4	58.1	9.72	2.41	68.63	9.62	72.57
1162.8	67.7	9.69	2.38	86.31	11.30	86.30
1144.6	81.5	11.36	3.07	54.57	11.03	73.80
1267.2	89.7	11.35	3.06	64.47	12.29	81.75
1449.6	101.7	11.33	3.05	80.17	13.99	93.60
1570.0	109.5	11.32	3.03	91.11	15.11	101.44
1867.2	128.3	11.29	3.00	115.91	17.83	120.82
1972.3	192.7	13.48	4.26	68.48	17.65	109.68
2185.2	212.6	13.47	4.25	82.37	20.56	121.57
2502.1	241.9	13.45	4.23	104.32	24.64	139.32
2711.8	261.0	13.44	4.22	119.18	26.78	151.07
3230.7	307.7	13.42	4.19	158.80	31.73	180.22
3052.7	231.8	15.18	4.23	95.42	21.59	149.00
3496.8	263.9	15.17	4.21	121.62	25.93	170.79
3790.9	284.9	15.16	4.20	140.24	28.51	185.24
4519.2	336.0	15.13	4.17	187.56	34.65	221.09
4807.7	356.0	15.12	4.16	207.07	36.79	235.31

The properties shown are based on gross thicknesses beyond the scope of BS EN 1993-1-3 and are for reference only; design for construction must be based upon the use of the MetPurl span tables or software.

Z-SECTION PURLINS /SIDE RAILS

The configurations below represent those of a sleeved system. Butted systems do not require the second pair of holes towards the centre of the part. Our standard hole details are as follows:

Default

All holes 18mm diameter to suit M16 (grade 8.8) bolts. All incoming accessories to be 18mm diameter.

Z123 SERIES

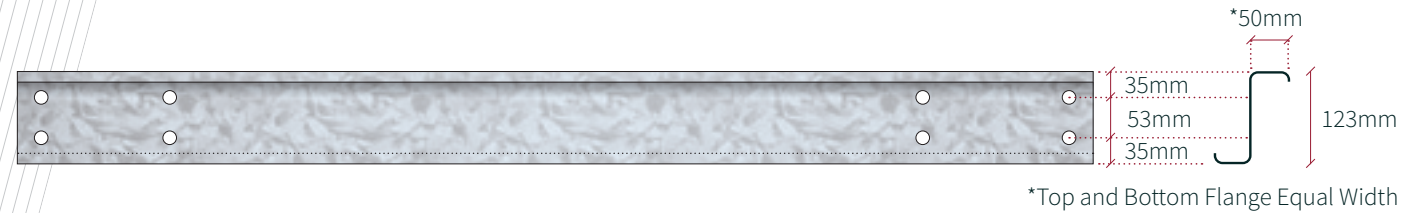

Z143 SERIES



Z173 SERIES



Z203 SERIES

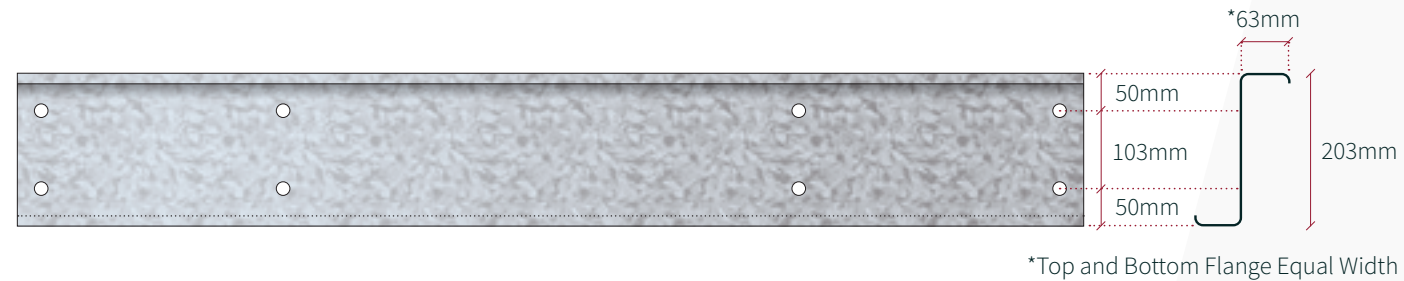

Z233 SERIES

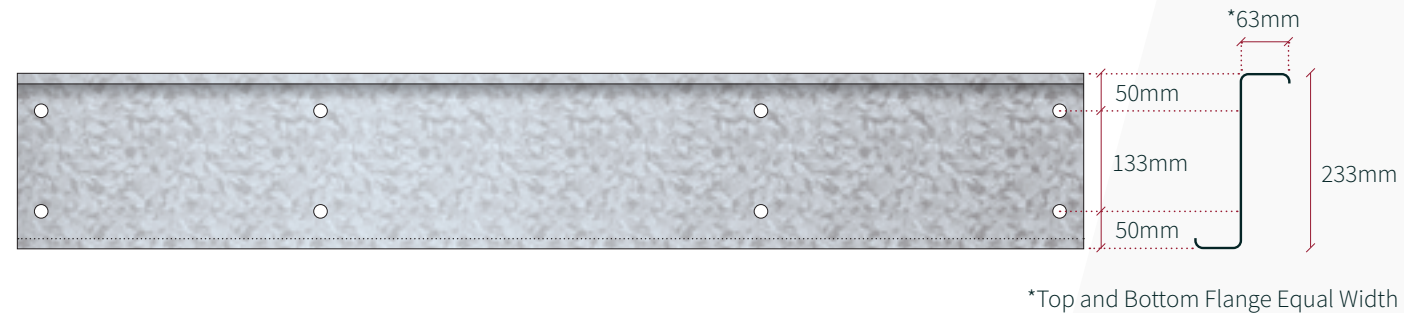

Z263 SERIES

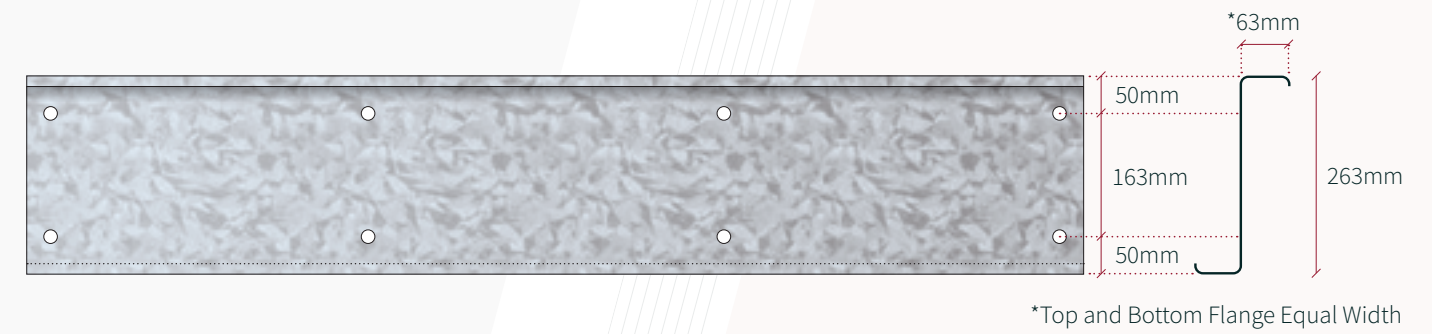

Z303 SERIES

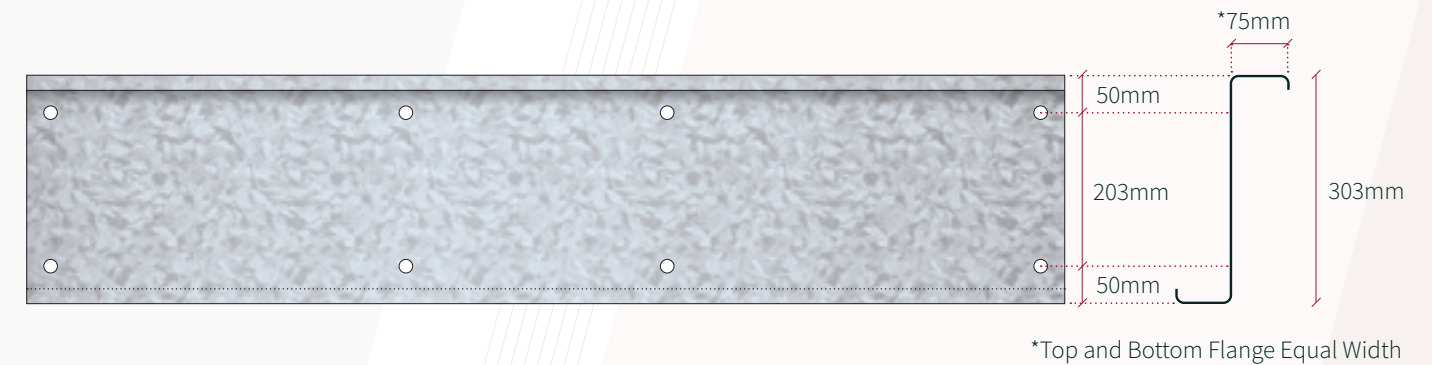

Z353 SERIES

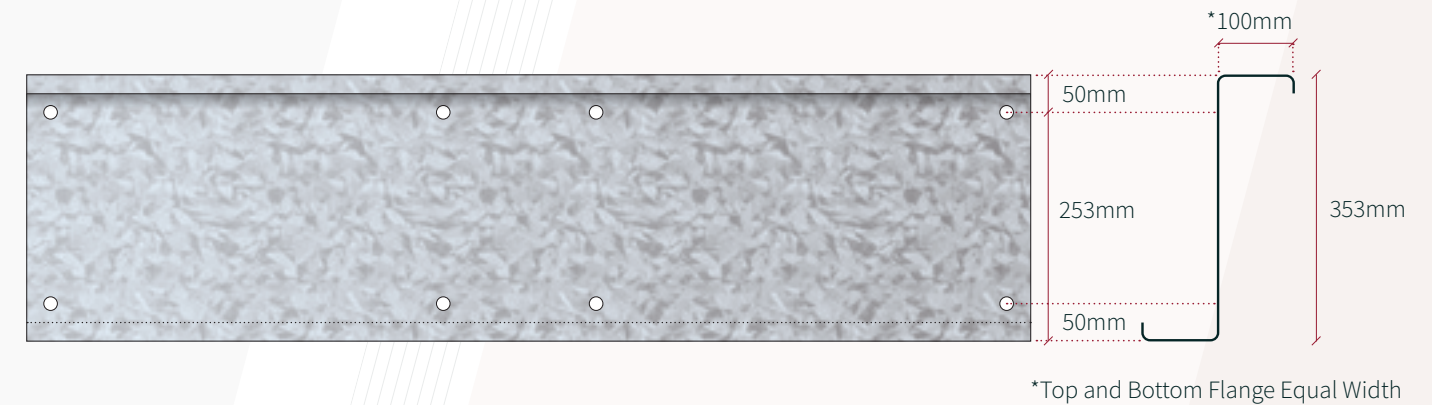

Z403 SERIES

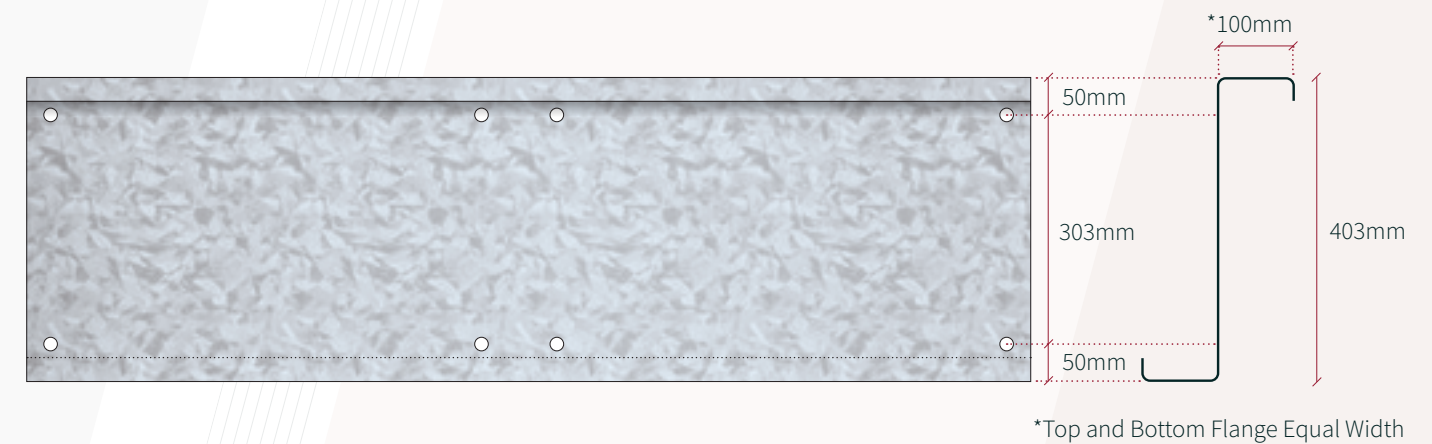

C-SECTION DIMENSIONS & PROPERTIES

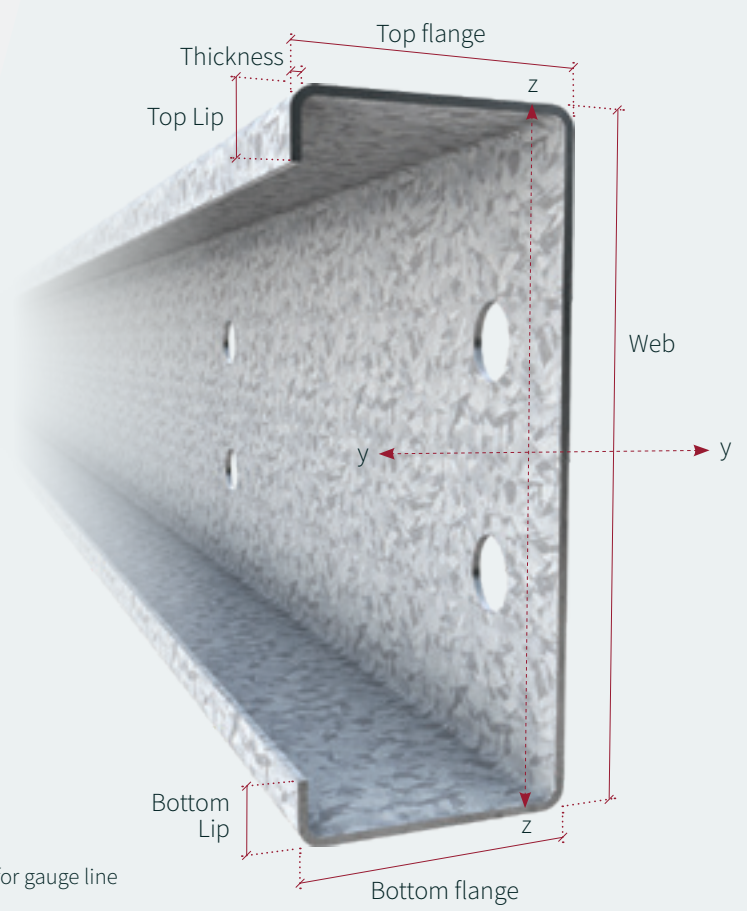

Our Cee profiles references work in the same way as the Zed profiles; the C refers to the profile shape; the next three digits are the section depth, ie. 123 = 123mm deep; the final two digits equate to the section thickness, so 15 = 1.5mm thickness.

Material

All our sections are cold-formed from hot dipped Z275 galvanized S450GD steel to BS EN 10346:2015 and BS EN 10143:2006, with a minimum yield strength of 450N/mm². Z275 provides an average coating of 20 microns each side. Please contact CMF for advice on other coatings such as Magnelis / Z600.

Sleeves

The Cee profile sleeves are a non-lipped C profile allowing the side rails to fit into the sleeve with maximum support. The references follow those of the Zed. The letter references identify the type of sleeves required, ie. **CS14314 - CS** = Cee Sleeve; **CHS20315 - CHS** = Cee Heavy End Bay Sleeve. The number references match those of the above sections.

See page 14 - 15 for gauge line

Section Reference	Section thickness (mm)	Top flange width (mm)	Bottom flange width (mm)	Web depth (mm)	Top lip length (mm)	Bottom lip length (mm)	Weight (kg/m)	I _y (cm ⁴)	I _z (cm ⁴)	i _y (cm)	i _z (cm)	W _{eff,y} (cm ³)	W _{eff,z} (cm ³)	W _{ely} (cm ³)
C12315	1.50	50	50	123	14	14	2.79	87.8	11.9	4.81	1.83	13.04	3.54	13.61
C12316	1.60	50	50	123	14	14	2.96	93.3	12.6	4.81	1.82	14.13	3.76	14.47
C14313	1.30	58	58	143	14	14	2.79	119.2	15.8	5.63	2.10	12.92	3.94	15.97
C14314	1.40	58	58	143	14	14	3.00	127.9	16.9	5.62	2.10	14.55	4.24	17.15
C14315	1.50	58	58	143	14	14	3.21	136.7	18.0	5.62	2.09	16.25	4.53	18.33
C14316	1.60	58	58	143	14	14	3.42	145.3	19.1	5.61	2.09	18.00	4.81	19.51
C14318	1.80	58	58	143	14	14	3.83	162.5	21.3	5.60	2.08	21.12	5.36	21.83
C14320	2.00	58	58	143	14	14	4.23	179.4	23.3	5.60	2.07	24.06	5.91	24.14
C17313	1.30	63	63	173	14	14	3.20	194.9	20.6	6.75	2.24	16.17	4.58	21.70
C17314	1.40	63	63	173	14	14	3.44	209.3	22.1	6.74	2.24	18.23	4.94	23.31
C17315	1.50	63	63	173	14	14	3.68	223.7	23.5	6.74	2.23	20.37	5.27	24.92
C17316	1.60	63	63	173	14	14	3.92	237.9	24.9	6.73	2.23	22.59	5.60	26.53
C17318	1.80	63	63	173	14	14	4.39	266.2	27.8	6.72	2.22	27.25	6.25	29.71
C17320	2.00	63	63	173	14	14	4.86	294.2	30.5	6.71	2.21	32.03	6.88	32.87
C17323	2.30	63	63	173	14	14	5.56	335.6	34.5	6.70	2.20	37.56	7.82	37.55
C17325	2.50	63	63	173	14	14	6.01	362.9	37.1	6.69	2.19	40.64	8.43	40.64

Section Reference	Section thickness (mm)	Top flange width (mm)	Bottom flange width (mm)	Web depth (mm)	Top lip length (mm)	Bottom lip length (mm)	Weight (kg/m)	I _y (cm ⁴)	I _z (cm ⁴)	i _y (cm)	i _z (cm)	W _{eff,y} (cm ³)	W _{eff,z} (cm ³)	W _{ely} (cm ³)
C20313	1.30	63	63	203	14	14	3.51	282.9	21.7	7.78	2.20	19.23	4.67	26.92
C20314	1.40	63	63	203	14	14	3.77	303.9	23.2	7.78	2.19	21.67	5.03	28.93
C20315	1.50	63	63	203	14	14	4.04	324.8	24.7	7.77	2.19	24.22	5.37	30.93
C20316	1.60	63	63	203	14	14	4.30	345.6	26.2	7.77	2.19	26.86	5.70	32.93
C20318	1.80	63	63	203	14	14	4.82	386.9	29.2	7.76	2.18	32.37	6.36	36.90
C20320	2.00	63	63	203	14	14	5.33	427.8	32.1	7.75	2.17	38.18	7.01	40.83
C20323	2.30	63	63	203	14	14	6.10	488.4	36.3	7.73	2.15	46.67	7.97	46.67
C20325	2.50	63	63	203	14	14	6.60	528.2	39.1	7.72	2.14	50.52	8.59	50.52
C20327	2.70	63	63	203	14	14	7.10	567.6	41.7	7.71	2.14	54.34	9.20	54.34
C23314	1.40	63	63	233	14	14	4.10	420.6	24.2	8.79	2.15	25.16	5.11	34.98
C23315	1.50	63	63	233	14	14	4.39	449.7	25.8	8.79	2.14	28.11	5.45	37.40
C23316	1.60	63	63	233	14	14	4.67	478.6	27.3	8.78	2.14	31.17	5.79	39.82
C23318	1.80	63	63	233	14	14	5.24	535.9	30.4	8.77	2.13	37.57	6.46	44.63
C23320	2.00	63	63	233	14	14	5.80	592.8	33.4	8.76	2.12	44.30	7.12	49.40
C23323	2.30	63	63	233	14	14	6.64	677.1	37.8	8.74	2.11	54.22	8.09	56.49
C23325	2.50	63	63	233	14	14	7.19	732.6	40.7	8.73	2.10	60.23	8.72	61.17
C23327	2.70	63	63	233	14	14	7.74	787.6	43.5	8.72	2.09	65.81	9.34	65.81
C26316	1.60	63	63	263	14	14	5.05	638.9	28.3	9.77	2.09	35.54	5.86	47.20
C26318	1.80	63	63	263	14	14	5.66	715.7	31.5	9.76	2.08	42.83	6.54	52.91
C26320	2.00	63	63	263	14	14	6.27	791.9	34.6	9.75	2.07	50.49	7.21	58.58
C26323	2.30	63	63	263	14	14	7.18	904.9	39.1	9.73	2.06	61.80	8.19	67.01
C26325	2.50	63	63	263	14	14	7.78	979.4	42.1	9.72	2.05	68.65	8.83	72.57
C26330	3.00	63	63	263	14	14	9.27	1162.8	49.1	9.69	2.03	86.31	10.38	86.30
C30318	1.80	75	75	303	20	20	6.74	1144.6	57.6	11.36	2.58	54.58	10.05	73.80
C30320	2.00	75	75	303	20	20	7.47	1267.2	63.4	11.35	2.58	64.47	11.27	81.75
C30323	2.30	75	75	303	20	20	8.56	1449.6	72.0	11.33	2.56	80.17	12.83	93.60
C30325	2.50	75	75	303	20	20	9.28	1570.0	77.5	11.32	2.55	91.11	13.86	101.44
C30330	3.00	75	75	303	20	20	11.06	1867.2	91.0	11.29	2.53	115.94	16.36	120.82
C35318	1.80	100	100	353	25	25	8.30	1972.3	131.7	13.48	3.52	68.58	16.36	109.68
C35320	2.00	100	100	353	25	25	9.20	2185.2	145.4	13.47	3.52	82.45	18.68	121.57
C35323	2.30	100	100	353	25	25	10.54	2502.1	165.5	13.45	3.50	104.36	22.26	139.32
C35325	2.50	100	100	353	25	25	11.44	2711.8	178.8	13.44	3.49	119.19	24.28	151.07
C35330	3.00	100	100	353	25	25	13.65	3230.7	211.0	13.42	3.47	158.80	28.77	180.22
C40320	2.00	100	100	403	30	30	10.14	3052.7	162.0	15.18	3.54	95.54	19.27	149.00
C40323	2.30	100	100	403	30	30	11.63	3496.8	184.5	15.17	3.52	121.70	23.08	170.79
C40325	2.50	100	100	403	30	30	12.62	3790.9	199.3	15.16	3.51	140.30	25.70	185.24
C40330	3.00	100	100	403	30	30	15.07	4519.2	235.4	15.13	3.49	187.56	31.80	221.09
C40332	3.20	100	100	403	30	30	16.04	4807.7	249.5	15.12	3.48	207.07	33.76	235.31

The properties shown are based on gross thicknesses beyond the scope of BS EN 1993-1-3 and are for reference only; design for construction must be based upon the use of the MetPurl span tables or software.

C-SECTION SIDE RAILS

The configurations below represent those of a sleeved system, a butted system would be without the second pair of holes towards the centre of the part. Our standard hole details are as follows:

Default

All holes 18mm diameter to suit M16 (grade 8.8) bolts. All incoming accessories to be 18mm diameter.

C123 SERIES

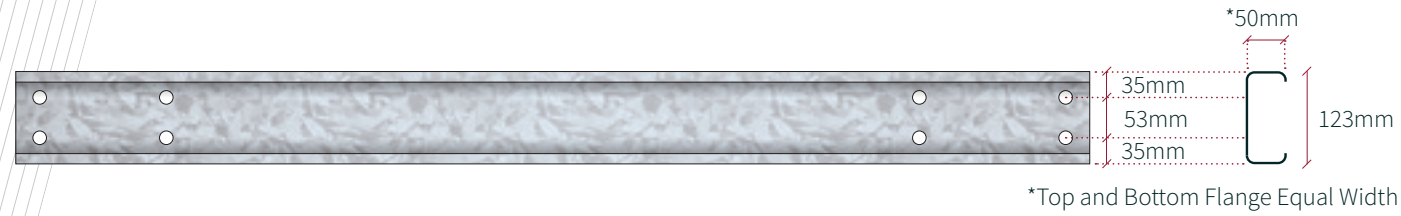

C143 SERIES

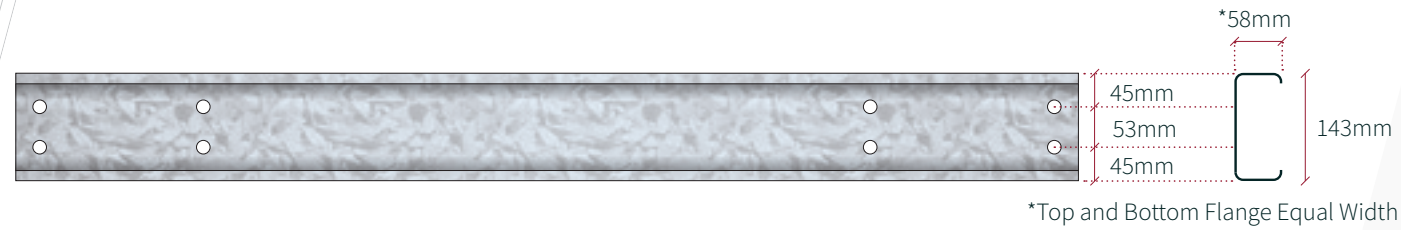

C173 SERIES

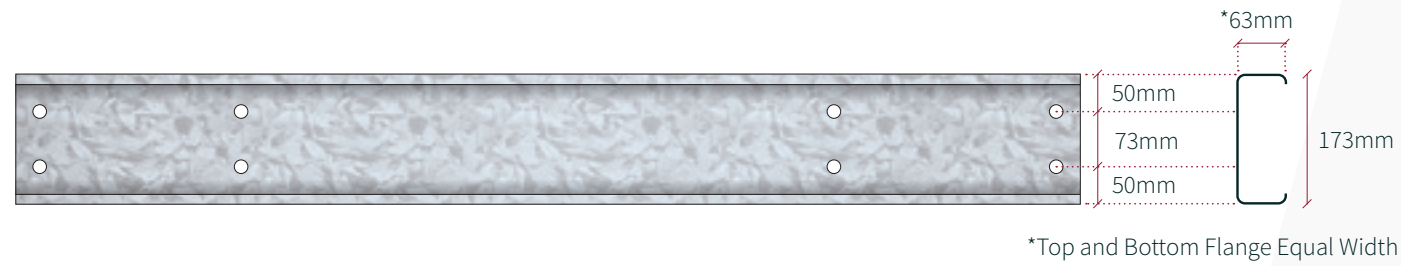

C203 SERIES

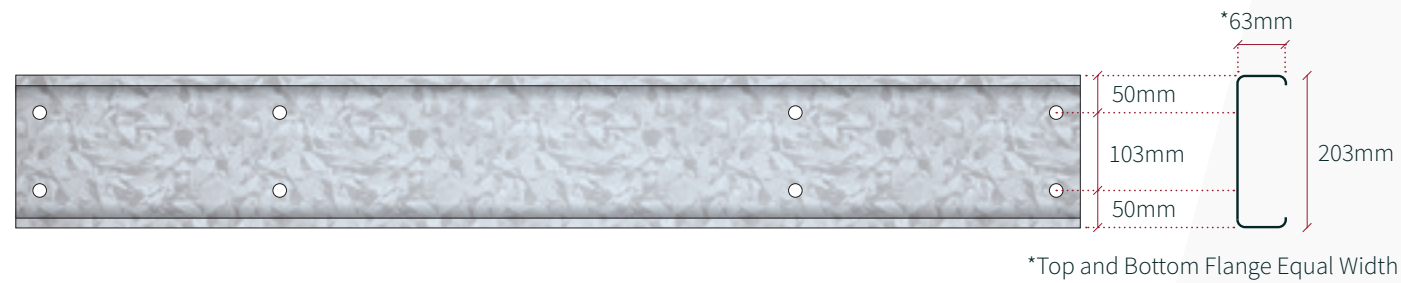

C233 SERIES

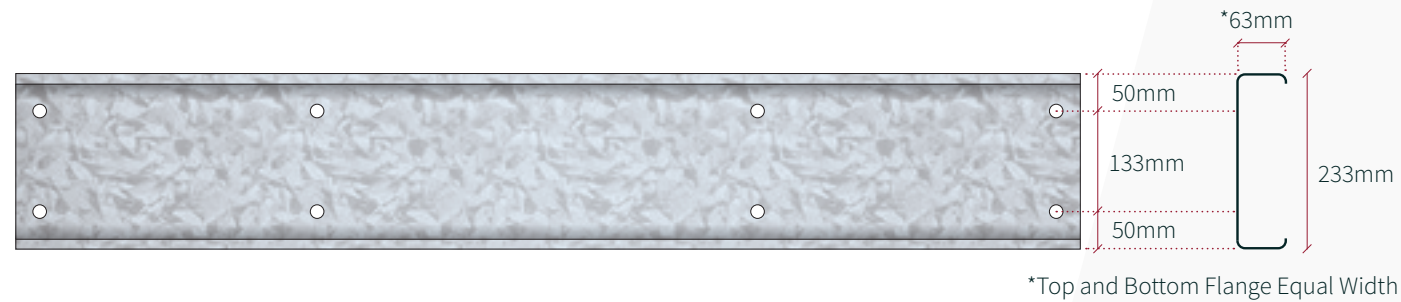

C263 SERIES

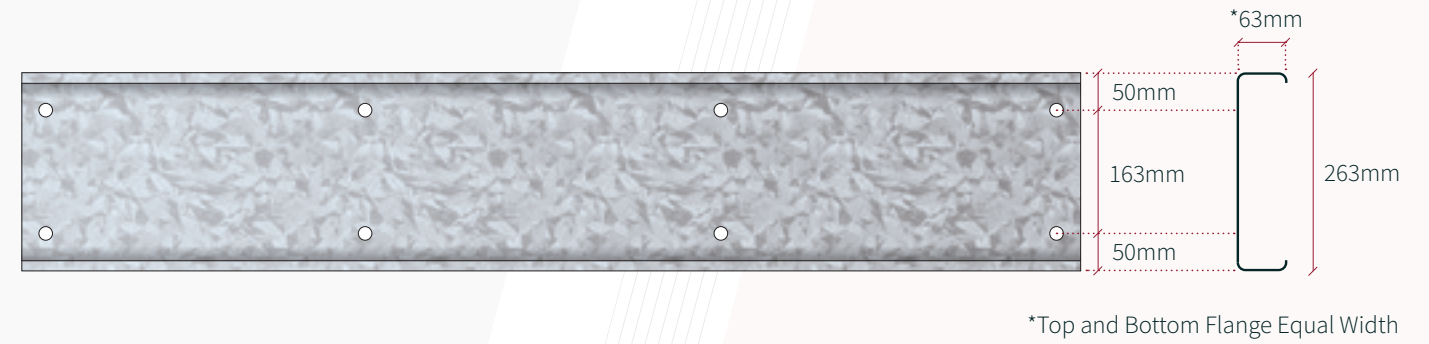

C303 SERIES

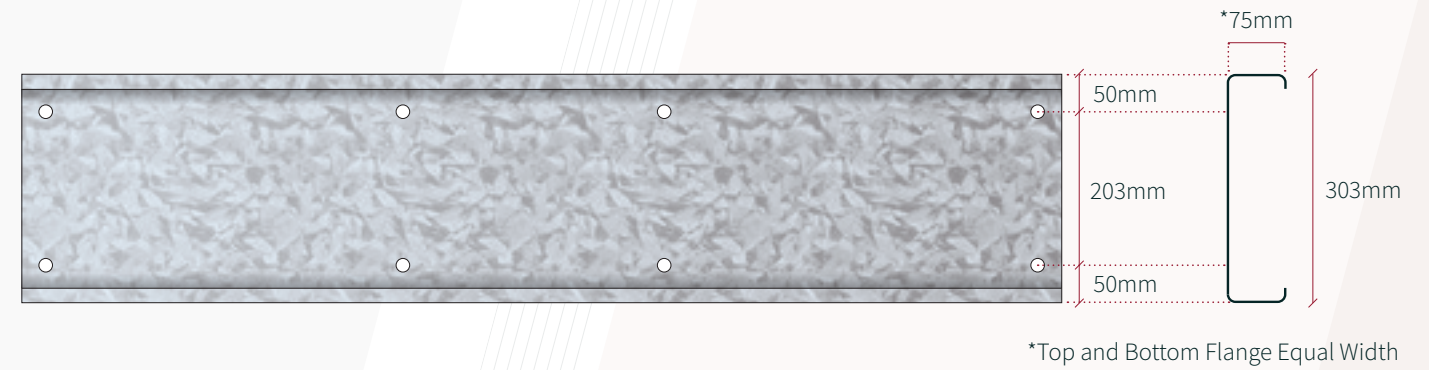

C353 SERIES

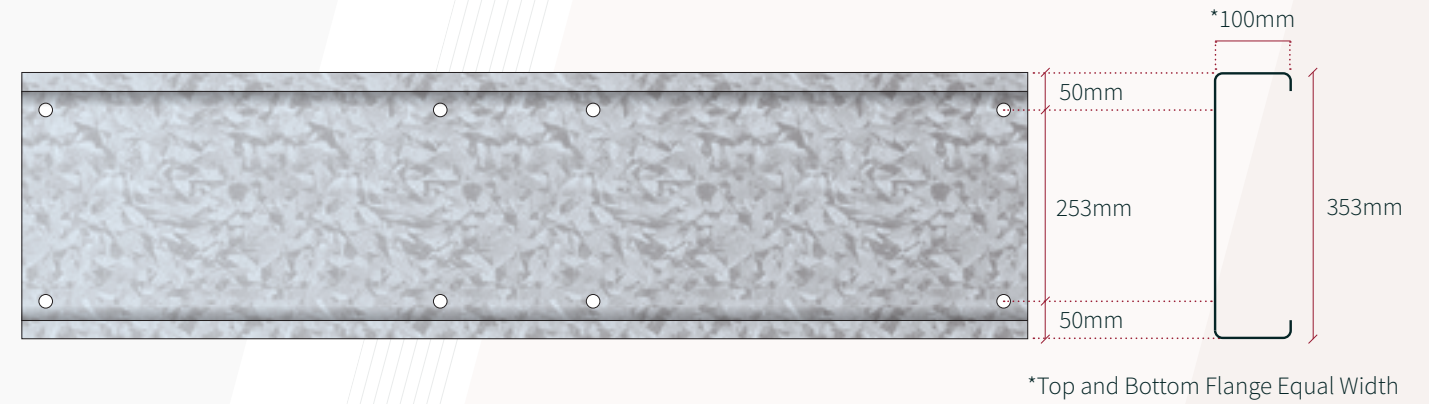

C403 SERIES



WIDE FLANGE Z-SECTION DIMENSIONS & PROPERTIES

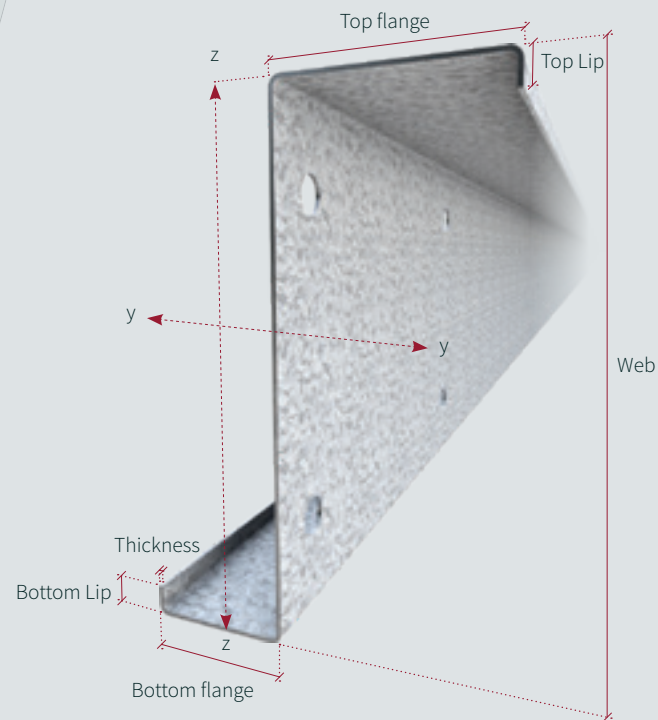

See page 10 - 11 for gauge line information only. Please note the difference in flange widths.

We have developed a Wide Top Flange Zed to accommodate the change in cladding types. There is a minimum thickness of 1.6mm for these sections due to the effectiveness of the longer flange. Reference for this product is; **Wide Zed = WZ17320**.

Material

All our sections are cold-formed from hot dipped Z275 galvanized S450GD steel to BS EN 10346:2015 and BS EN 10143:2006, with a minimum yield strength of 450N/mm². Z275 provides an average coating of 20 microns each side. Please contact CMF for advice on other coatings such as Magnelis / Z600.

Sleeves

The complimenting sleeves to suit our WZ range are asymmetric to allow a snug fit and maximum support. The letter references identify the type of sleeves required ie, **WZS14314** - **WS** = Wide Sleeve; **WHS20315** - **WHS** = Wide Heavy End Bay Sleeve. The number references match those of the above sections.

WIDE FLANGE C-SECTION DIMENSIONS & PROPERTIES

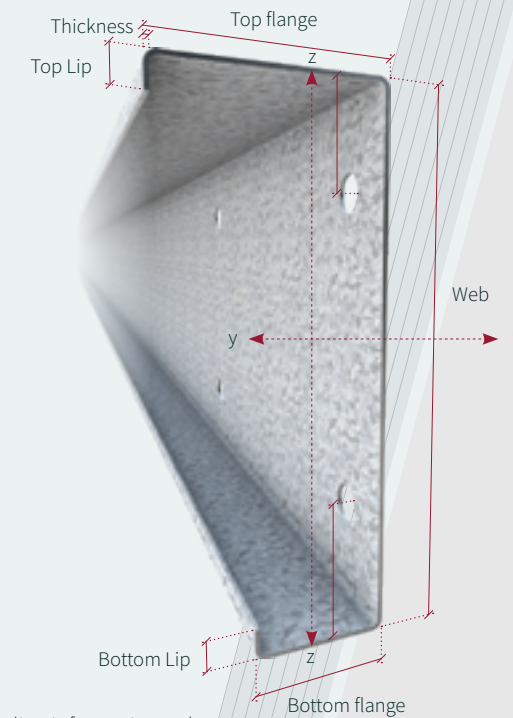

See page 14 - 15 for gauge line information only. Please note the difference in flange widths.

As with the Wide Top Flange Zed we have adopted the same principles to accommodate the change in cladding types on the walls of a building. There is a minimum thickness of 1.6mm for these sections due to the effectiveness of the longer flange. Reference for this product is; **Wide Cee = WC2039315**.

Material

All our sections are cold-formed from hot dipped Z275 galvanized S450GD steel to BS EN 10346:2015 and BS EN 10143:2006, with a minimum yield strength of 450N/mm². Z275 provides an average coating of 20 microns each side. Please contact CMF for advice on other coatings such as Magnelis / Z600.

Sleeves

The complimenting sleeves to suit our WC range are the same as those used on the standard Cee sleeve systems. Refer to page 12 for dimensions.

Section Reference	Section thickness (mm)	Top flange width (mm)	Bottom flange width (mm)	Web depth (mm)	Top lip length (mm)	Bottom lip length (mm)	Weight (kg/m)
WZ2039316	1.60	93	63	203	14	14	4.67
WZ2039318	1.80	93	63	203	14	14	5.24
WZ2039320	2.00	93	63	203	14	14	5.80
WZ2039323	2.30	93	63	203	14	14	6.64
WZ2039325	2.50	93	63	203	14	14	7.19
WZ2039327	2.70	93	63	203	14	14	7.74
WZ2339316	1.60	93	63	233	14	14	5.05
WZ2339318	1.80	93	63	233	14	14	5.66
WZ2339320	2.00	93	63	233	14	14	6.27
WZ2339323	2.30	93	63	233	14	14	7.18
WZ2339325	2.50	93	63	233	14	14	7.78
WZ2639316	1.60	93	63	263	14	14	5.43
WZ2639318	1.80	93	63	263	14	14	6.09
WZ2639320	2.00	93	63	263	14	14	6.75
WZ2639323	2.30	93	63	263	14	14	7.72
WZ2639325	2.50	93	63	263	14	14	8.37
WZ2639330	3.00	93	63	263	14	14	9.97

I_y (cm ⁴)	I_z (cm ⁴)	i_y (cm)	i_z (cm)	$W_{eff,y}$ (cm ³)	$W_{eff,z}$ (cm ³)	$W_{el,y}$ (cm ³)
390.5	72.8	7.93	3.49	28.41	7.98	40.52
437.3	81.2	7.92	3.48	34.58	9.38	45.43
483.6	89.3	7.91	3.47	41.20	10.64	50.30
552.3	101.3	7.90	3.45	47.86	12.11	57.54
597.6	109.1	7.89	3.43	52.16	13.07	62.32
642.4	116.7	7.88	3.42	56.45	14.01	67.06
538.1	73.2	8.97	3.37	32.93	7.97	48.45
602.8	81.6	8.96	3.36	40.06	9.37	54.32
667.0	89.9	8.95	3.34	47.71	10.64	60.16
762.1	101.9	8.93	3.33	57.90	12.11	68.84
824.9	109.7	8.92	3.31	63.13	13.07	74.57
715.3	73.6	9.99	3.26	37.49	7.96	56.85
801.6	82.0	9.98	3.25	45.61	9.35	63.75
887.1	90.3	9.97	3.23	54.29	10.64	70.61
1014.1	102.4	9.95	3.22	68.27	12.11	80.82
1097.9	110.3	9.94	3.20	74.85	13.07	87.57
1304.4	129.3	9.91	3.17	90.32	15.40	104.25

The properties shown are based on gross thicknesses beyond the scope of BS EN 1993-1-3 and are for reference only; design for construction must be based upon the use of the MetPurl span tables or software.

Section Reference	Section thickness (mm)	Top flange width (mm)	Bottom flange width (mm)	Web depth (mm)	Top lip length (mm)	Bottom lip length (mm)	Weight (kg/m)
WC2039316	1.60	93	63	203	14	14	4.67
WC2039318	1.80	93	63	203	14	14	5.24
WC2039320	2.00	93	63	203	14	14	5.80
WC2039323	2.30	93	63	203	14	14	6.64
WC2039325	2.50	93	63	203	14	14	7.19
WC2039327	2.70	93	63	203	14	14	7.74
WC2339316	1.60	93	63	233	14	14	5.05
WC2339318	1.80	93	63	233	14	14	5.66
WC2339320	2.00	93	63	233	14	14	6.27
WC2339323	2.30	93	63	233	14	14	7.18
WC2339325	2.50	93	63	233	14	14	7.78
WC2639316	1.60	93	63	263	14	14	5.43
WC2639318	1.80	93	63	263	14	14	6.09
WC2639320	2.00	93	63	263	14	14	6.75
WC2639323	2.30	93	63	263	14	14	7.72
WC2639325	2.50	93	63	263	14	14	8.37
WC2639330	3.00	93	63	263	14	14	9.97

I_y (cm ⁴)	I_z (cm ⁴)	i_y (cm)	i_z (cm)	$W_{eff,y}$ (cm ³)	$W_{eff,z}$ (cm ³)	$W_{el,y}$ (cm ³)
390.5	49.3	7.93	2.87	28.43	6.92	34.60
437.3	55.0	7.92	2.86	34.60	7.86	38.78
483.6	60.6	7.91	2.86	41.20	8.67	42.92
552.3	68.9	7.90	2.84	47.86	9.87	49.07
597.6	74.2	7.89	2.83	52.16	10.66	53.13
642.4	79.5	7.88	2.82	56.45	11.43	57.16
538.1	51.4	8.97	2.82	32.95	7.00	41.85
602.8	57.4	8.96	2.81	40.08	8.01	46.91
667.0	63.2	8.95	2.80	47.71	8.84	51.94
762.1	71.8	8.93	2.79	57.91	10.06	59.40
824.9	77.3	8.92	2.78	63.13	10.87	64.33
715.3	53.2	9.99	2.77	37.51	7.07	49.60
801.6	59.4	9.98	2.76	45.62	8.14	55.61
887.1	65.4	9.97	2.75	54.29	8.98	61.58
1014.1	74.3	9.95	2.74	68.24	10.23	70.46
1097.9	80.1	9.94	2.73	74.85	11.04	76.32
1304.4	94.1	9.91	2.71	90.32	13.03	90.80

The properties shown are based on gross thicknesses beyond the scope of BS EN 1993-1-3 and are for reference only; design for construction must be based upon the use of the MetPurl span tables or software.

FLAT BACK EAVES BEAM DIMENSIONS & PROPERTIES

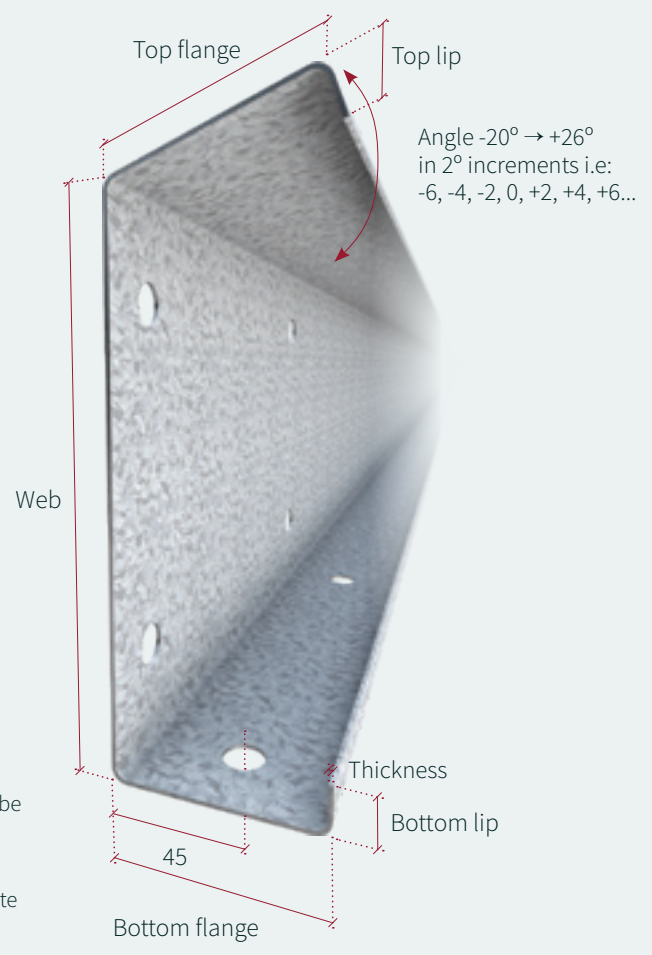

All holes 18mm diameter to suit M16 (grade 8.8) bolts.
All incoming accessories to be 18mm diameter.
Holes can be round or counterformed. Packing plate supplied by others.

To compliment our Purlin and Rail systems CMF have developed two different Eaves Beam profiles. Our first being a Flat Back Eaves Beam with standard 18mm diameter or counter-formed holes to suit M16 (8.8) bolts.

We have the ability to roll the top flange to a positive 26 degrees upwards to follow the angle of the roof pitch and -20 degrees typically used in mono pitched buildings. The variation of these can be achieved in 2° increments.

Eaves Beams are designed to perform as simply supported single span components with single spans of up to 16m. Reference for this product is: Eaves beam = E17320.

Material

All our sections are cold-formed from hot dipped Z275 galvanized S450GD steel to BS EN 10346:2015 and BS EN 10143:2006, with a minimum yield strength of 450N/mm^2 . Z275 provides an average coating of 20 microns each side. Please contact CMF for advice on other coatings such as Magnelis / Z600.

Section Reference	Section thickness (mm)	Top flange width (mm)	Bottom flange width (mm)	Web depth (mm)	Top lip length (mm)	Bottom lip length (mm)	Weight (kg/m)	I_y (cm ⁴)	I_z (cm ⁴)	i_y (cm)	i_z (cm)	$W_{eff,y}$ (cm ³)	$W_{eff,z}$ (cm ³)	W_{ely} (cm ³)
EB17315	1.50	85	85	173	22	22	4.39	283.5	56.9	6.98	3.18	22.30	9.18	31.83
EB17320	2.00	85	85	173	22	22	5.80	373.6	74.4	6.95	3.16	36.70	13.22	42.06
EB17323	2.30	85	85	173	22	22	6.64	426.6	84.6	6.94	3.15	44.43	15.25	48.11
EB20318	1.80	85	85	203	22	22	5.66	487.2	71.3	8.06	3.14	36.53	11.81	46.75
EB20320	2.00	85	85	203	22	22	6.27	539.0	78.6	8.05	3.13	43.63	13.48	51.78
EB20325	2.50	85	85	203	22	22	7.78	666.7	96.4	8.02	3.11	61.08	16.82	64.18
EB20330	3.00	85	85	203	22	22	9.27	791.5	113.5	8.00	3.08	76.38	19.89	76.37
EB23318	1.80	85	85	233	22	22	6.09	669.7	74.7	9.12	3.10	42.41	12.00	56.08
EB23320	2.00	85	85	233	22	22	6.75	741.3	82.3	9.11	3.09	50.63	13.70	62.11
EB23325	2.50	85	85	233	22	22	8.37	917.5	101.0	9.09	3.06	72.04	17.09	77.03
EB23330	3.00	85	85	233	22	22	9.97	1090.2	118.8	9.06	3.04	91.72	20.21	91.71
EB26320	2.00	90	90	263	25	25	7.47	1031.1	103.1	10.23	3.28	58.82	15.41	76.71
EB26325	2.50	90	90	263	25	25	9.28	1277.5	126.5	10.21	3.26	84.68	20.08	95.21
EB26330	3.00	90	90	263	25	25	11.06	1519.4	149.1	10.18	3.24	112.12	23.77	113.44
EB33325	2.50	105	105	333	30	30	11.44	2479.8	212.0	12.86	3.80	115.42	27.17	146.51
EB33330	3.00	105	105	333	30	30	13.65	2954.4	250.5	12.83	3.78	154.69	33.61	174.79

The properties shown are based on gross thicknesses beyond the scope of BS EN 1993-1-3 and are for reference only; design for construction must be based upon the use of the MetPurl span tables or software.

173

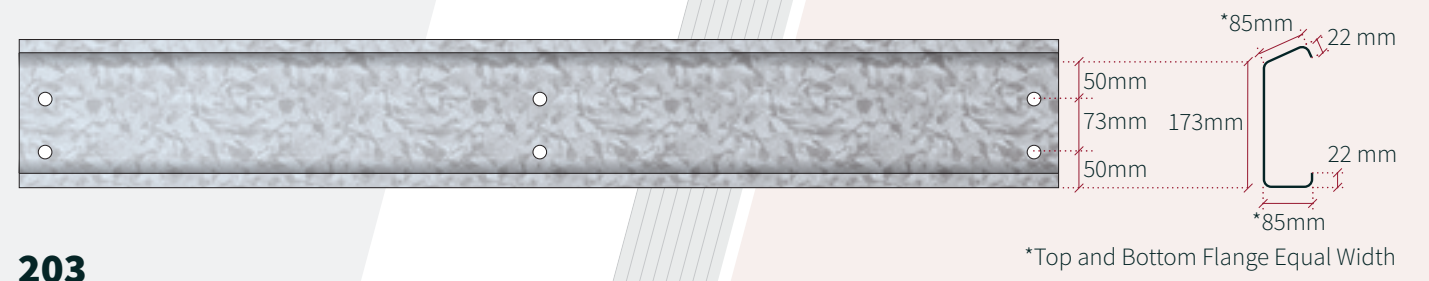

203

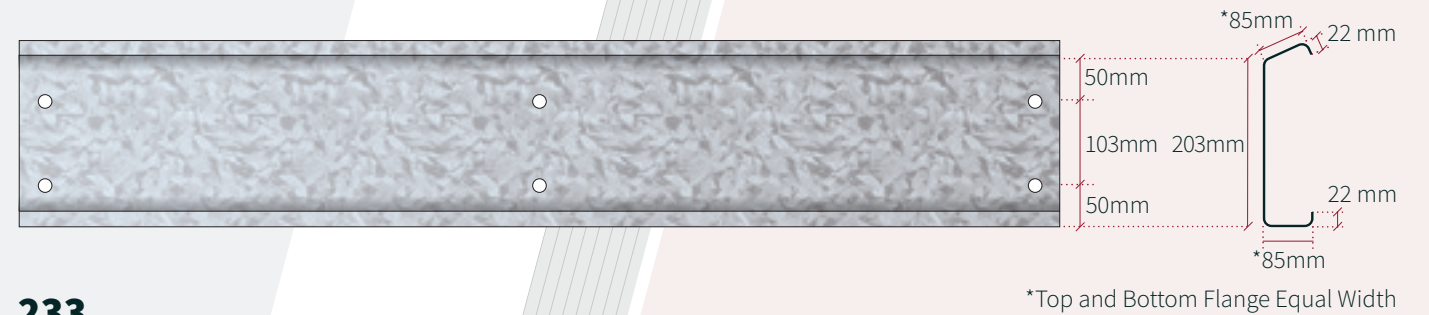

233

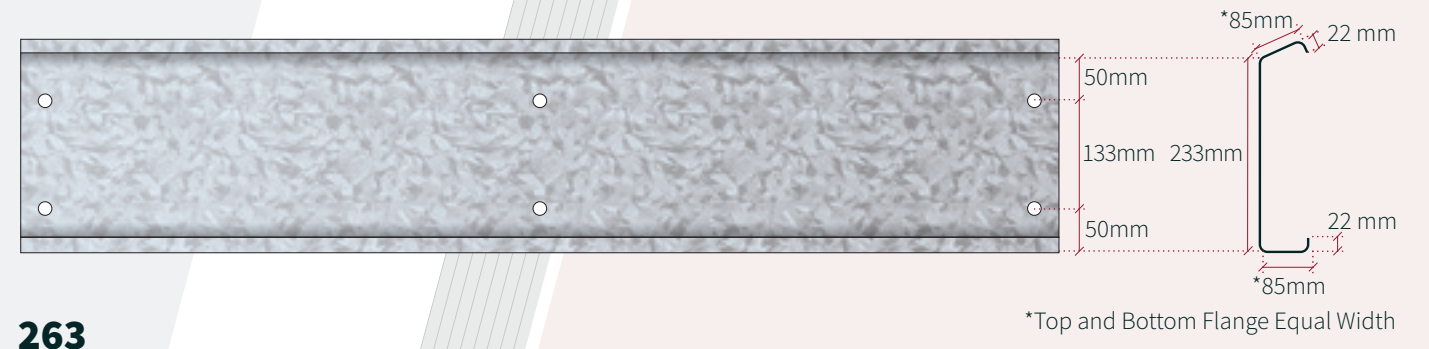

263

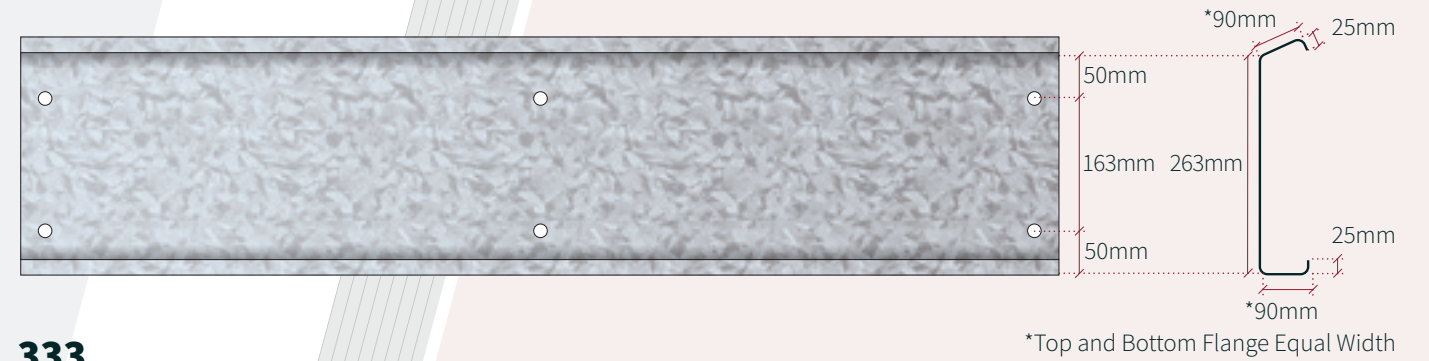

333

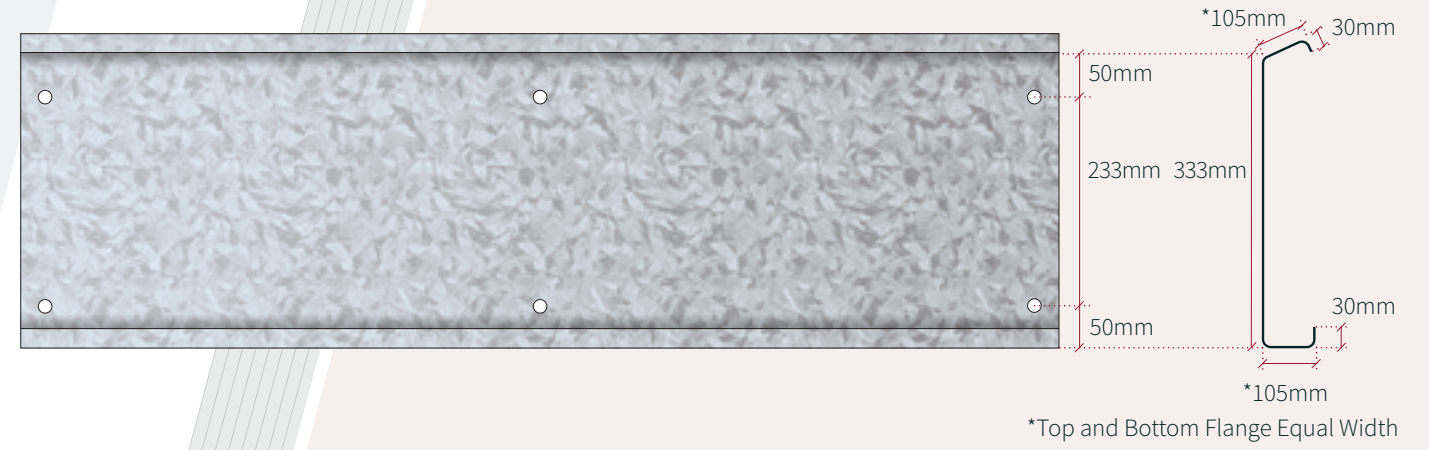

SIGMA EAVES BEAM DIMENSIONS & PROPERTIES

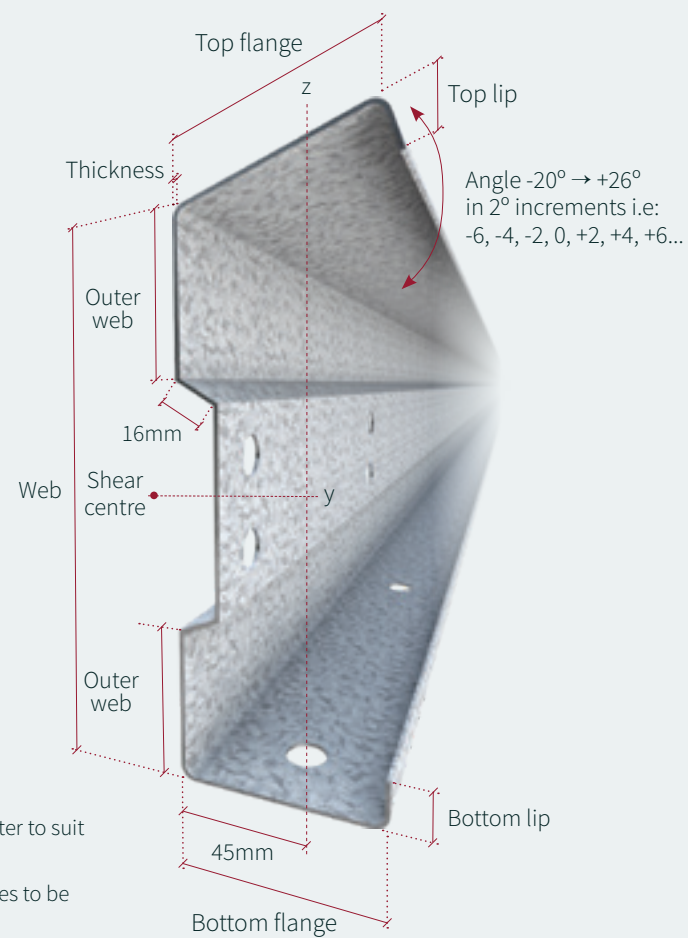

All holes 18mm diameter to suit M16 (grade 8.8) bolts.
All incoming accessories to be 18mm diameter.

As an alternative to the Flat Back Eaves Beam we have developed a Sigma profiled Eaves Beam with standard 18mm diameter holes to suit M16 (8.8) bolts. Due to the holes being in the recess of the web there is no requirement to counter-form the holes.

We can again roll the top flange to a positive 26 degrees upwards to follow the angle of the roof pitch and -20 degrees typically used in mono pitched buildings. The variation of pitches can be achieved in 2° increments.

Eaves Beams are design to perform as simply supported single span components with single spans of up to 16m. Reference for this product is: **Eaves Sigma = ES17320.**

Material

All our sections are cold-formed from hot dipped Z275 galvanized S450GD steel to BS EN 10346:2015 and BS EN 10143:2006, with a minimum yield strength of 450N/mm². Z275 provides an average coating of 20 microns each side. Please contact CMF for advice on other coatings such as Magnelis / Z600.

Section Reference	Section thickness (mm)	Flange width (mm)	Outer web (mm)	Web depth (mm)	Top lip length (mm)	Bottom lip length (mm)	Weight (kg/m)
ES17015	1.50	85	45	170	20	20	4.53
ES17020	2.00	85	45	170	20	20	4.85
ES17023	2.30	85	45	170	20	20	7.04
ES20018	1.80	85	45	200	20	20	5.99
ES20020	2.00	85	45	200	20	20	6.63
ES20025	2.50	85	45	200	20	20	8.21
ES20030	3.00	85	45	200	20	20	9.76
ES23018	1.80	85	65	230	20	20	6.42
ES23020	2.00	85	65	230	20	20	7.11
ES23025	2.50	85	65	230	20	20	8.80
ES23030	3.00	85	65	230	20	20	10.47
ES27018	1.80	85	65	270	24	24	7.10
ES27020	2.00	85	65	270	24	24	7.86
ES27025	2.50	85	65	270	24	24	9.75
ES27029	2.90	85	65	270	24	24	11.23
ES30020	2.00	85	75	300	24	24	8.33
ES30025	2.50	85	75	300	24	24	10.34
ES30030	3.00	85	75	300	24	24	12.31

I_y (cm ⁴)	I_z (cm ⁴)	i_y (cm)	i_z (cm)	$W_{eff,y}$ (cm ³)	$W_{eff,z}$ (cm ³)	W_{ely} (cm ³)
258.0	47.8	6.66	2.87	24.18	8.61	30.63
340.0	62.4	6.64	2.84	35.74	11.23	40.47
388.1	70.8	6.63	2.83	42.82	12.75	46.29
451.0	57.7	7.76	2.77	39.16	10.22	45.51
499.0	63.5	7.75	2.77	44.83	11.26	50.40
617.0	77.8	7.72	2.74	59.54	13.77	62.48
732.5	91.4	7.70	2.72	74.36	16.16	74.36
617.9	62.6	8.77	2.79	46.87	10.68	54.15
683.8	69.0	8.76	2.78	53.62	11.77	59.98
846.2	84.5	8.73	2.76	71.03	14.40	74.39
1005.2	99.3	8.71	2.74	88.57	16.92	88.56
925.9	68.1	10.20	2.77	59.26	11.67	69.05
1025.1	75.1	10.19	2.76	68.74	12.86	76.50
1270.0	92.0	10.17	2.74	91.02	15.76	94.95
1462.7	105.0	10.15	2.72	108.93	17.99	109.52
1314.5	77.9	11.20	2.73	78.64	13.09	88.22
1629.4	95.5	11.18	2.71	105.18	16.04	109.54
1938.8	112.3	11.15	2.68	130.56	18.87	130.56

The properties shown are based on gross thicknesses beyond the scope of BS EN 1993-1-3 and are for reference only; design for construction must be based upon the use of the MetPurl span tables or software.

170

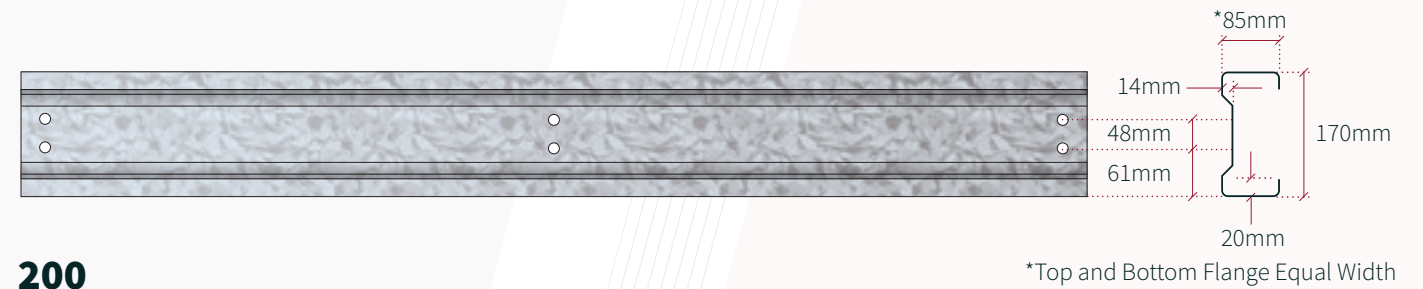

200

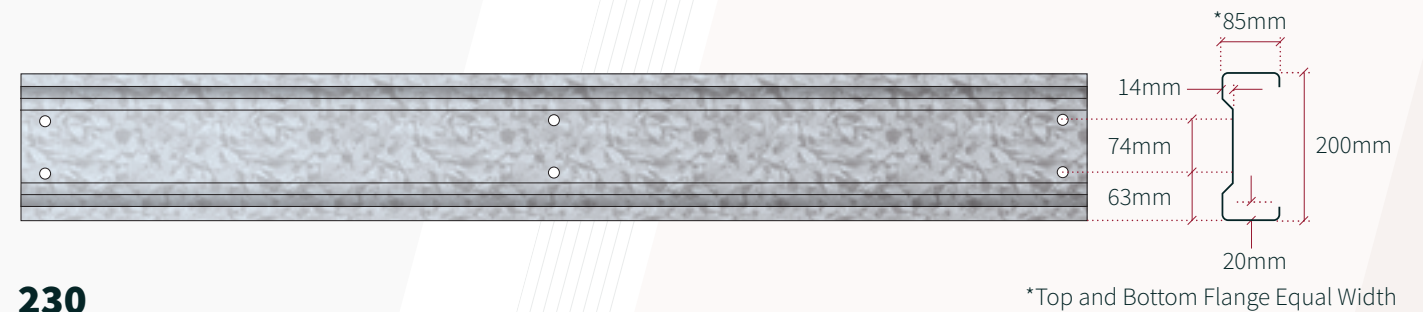

230

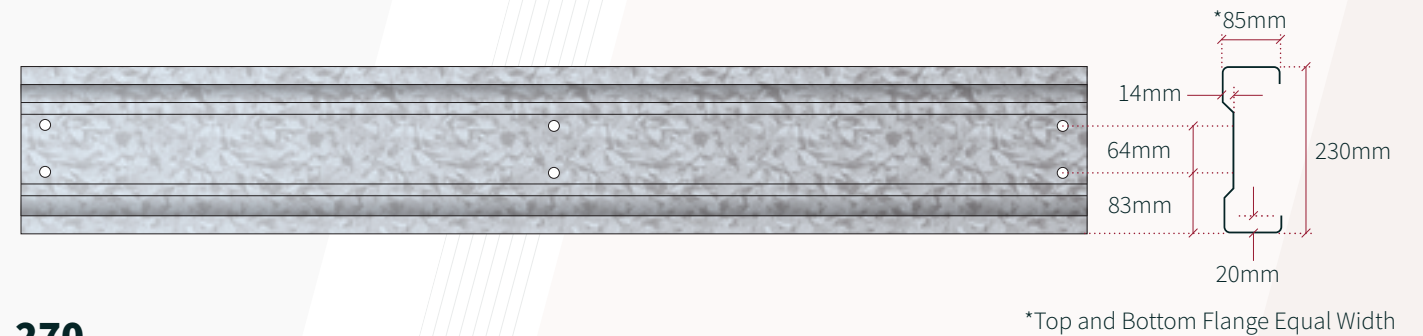

270

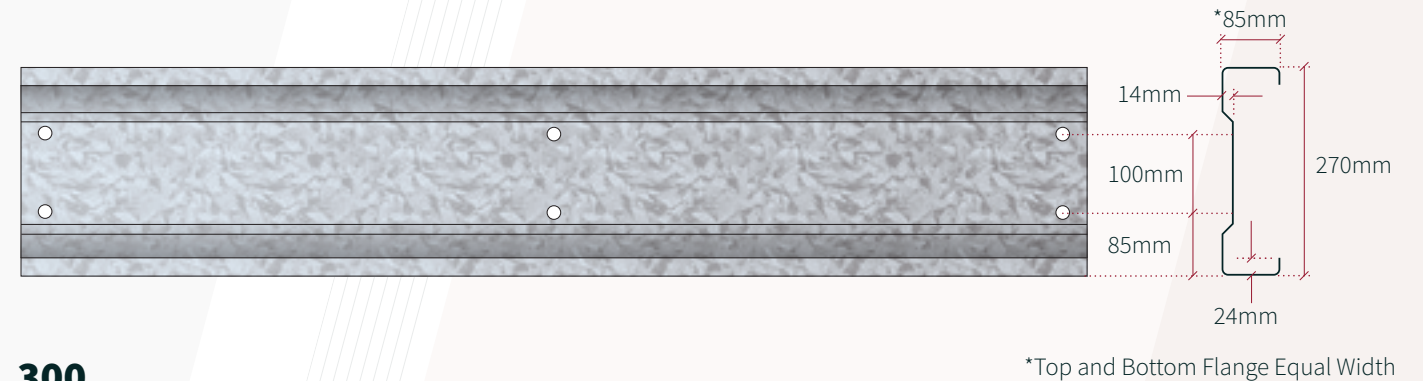

300

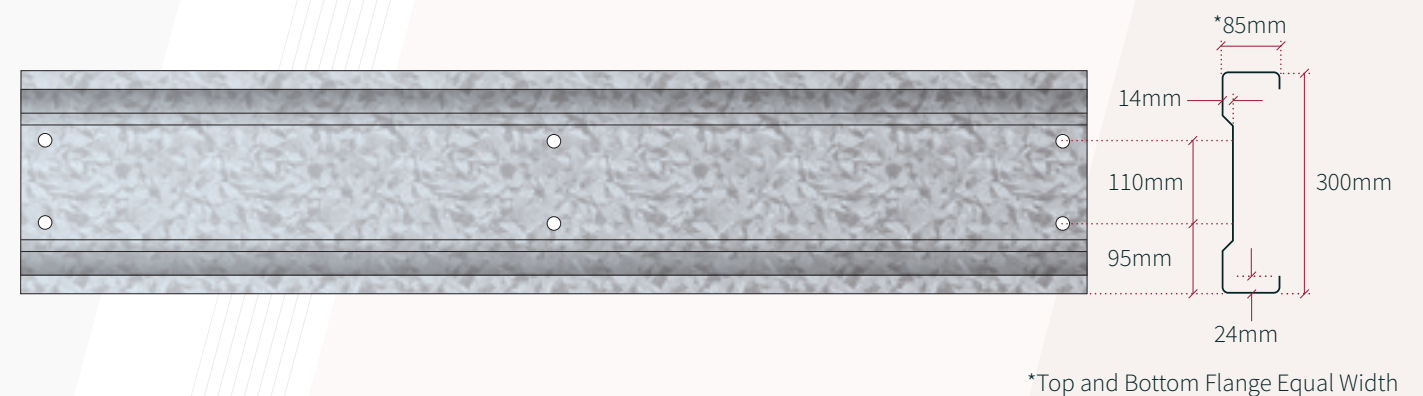

Z & C PURLIN & SIDE RAIL SYSTEM LAYOUTS

BUTTED SYSTEM

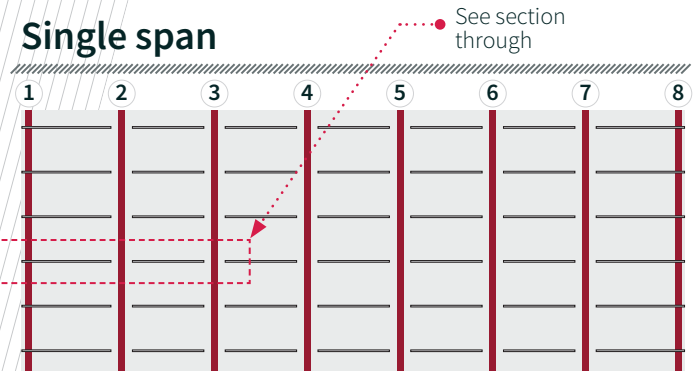

Single spanning butted systems are used when loadings are light. They are particularly useful when depth restrictions apply and can be designed to fit between the rafters/columns.

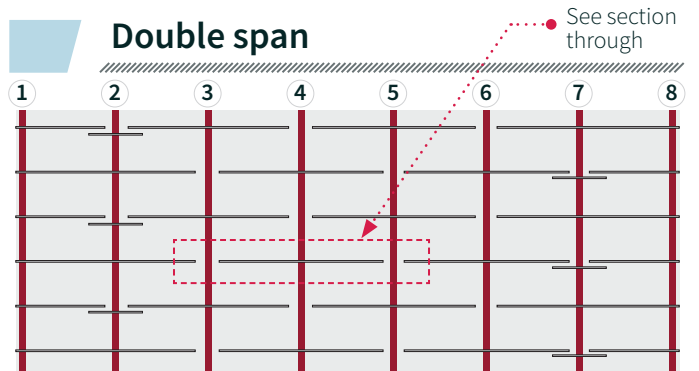

The double span butted system is designed to fit on the outside of the rafters/columns and has greater capacities than the single span butted system. All joints are staggered – in order to do this, the first section in alternate rows are single spanning with a sleeve at these joint positions.

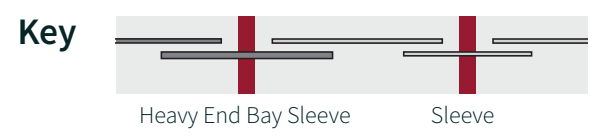

SLEEVED SYSTEM

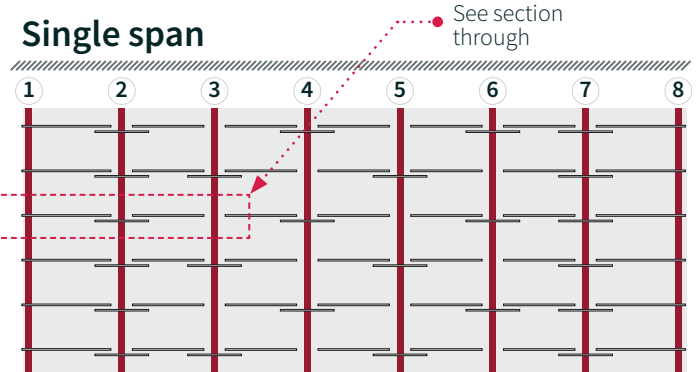

The single span sleeve system is the most widely used system between 2 and 5 bays. The sleeve offers continuity to the sections over the supports. Sleeves are applied to all rows on the penultimate rafter/column then staggered on all adjacent bays, alternating on each rafter back.

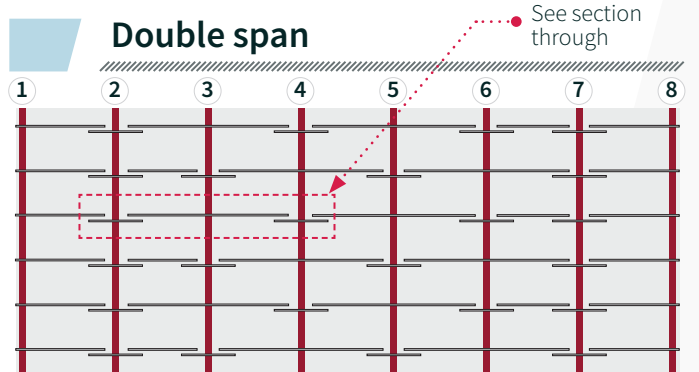

The double spanning sleeved system is a similar layout. Sleeves are applied to all rows on the penultimate rafter / column then staggered as per the diagram above.

Heavy end bay (HEB) – Single span

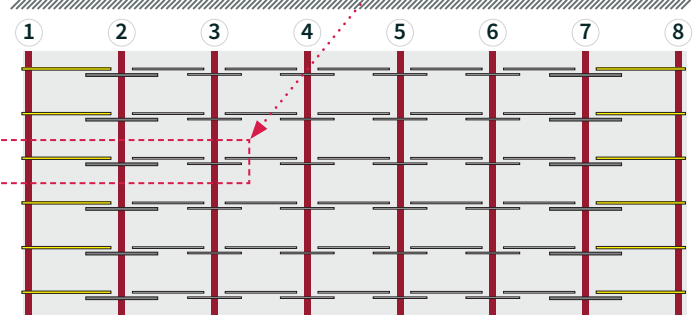

The Heavy End Bay (HEB) single span sleeved system is an economical use of sections for buildings of five or more bays. The use of heavier end sections and longer heavier sleeves allows the use of lighter gauge sections to all the inner bays. Sleeves are applied to all joint positions, with a Heavy End Bay sleeve on each penultimate rafter / column.

Heavy end bay (HEB) – Double span

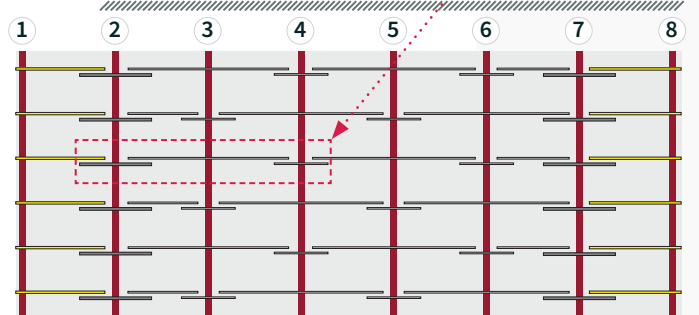

The double spanning Heavy End Bay (HEB) system is similar to the single span in the general layout. HEB sleeves are applied to all rows on the penultimate rafter / column then standard sleeves staggered as per the diagram above. This system gives the opportunity to use fewer component parts for overall on-site efficiency.

BUTTED PURLIN & RAIL SYSTEM



Typical butted system layout below shows hole configurations around the connection.

Our standard hole sizes are:

- All holes 18mm diameter to suit M16 (grade 8.8) bolts.
- All incoming accessories to be 18mm diameter.
- Clearance from top of rafter / column to underside of purlin / rail = 7mm.

Butted system (mm)									
A	123	143	173	203	233	263	303	353	403
B	35	45	50	50	50	50	50	50	50
C	53	53	73	103	133	163	203	253	303
D	42	52	57	57	57	57	57	57	57

Single span layout

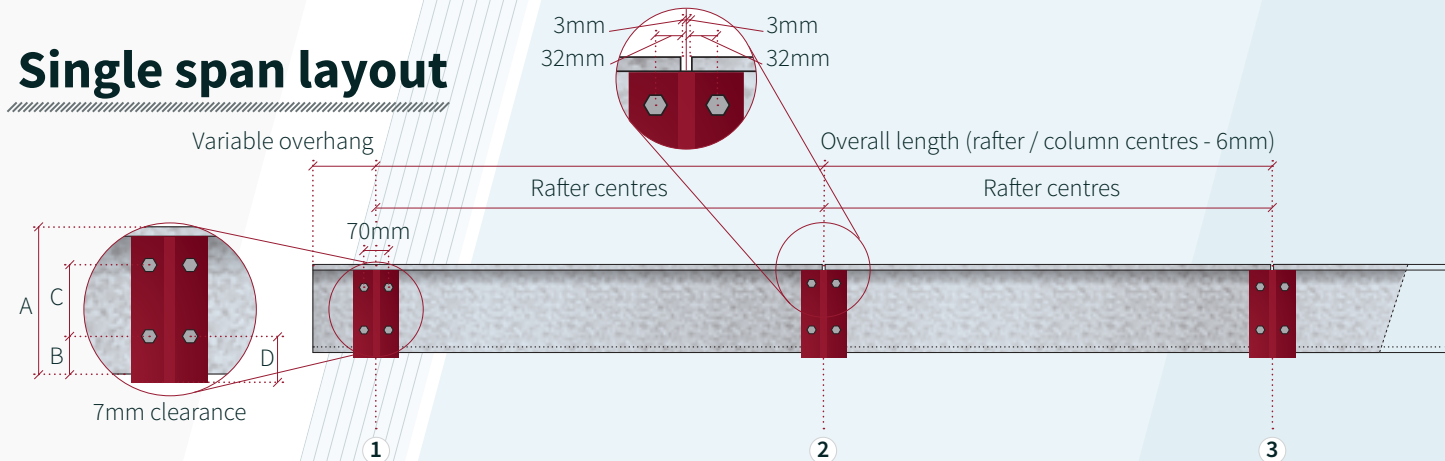

Double span layout

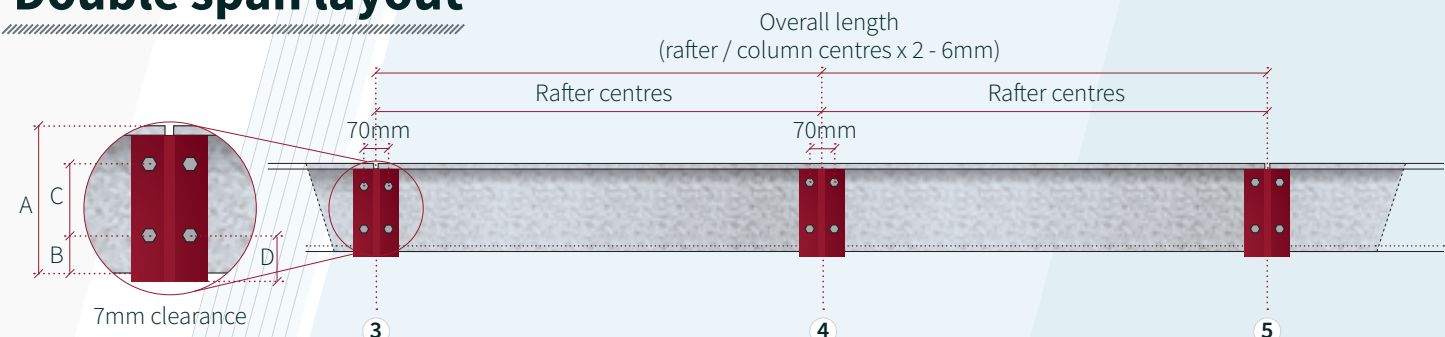

SLEEVED PURLIN & RAIL SYSTEM

For full layouts see page 22

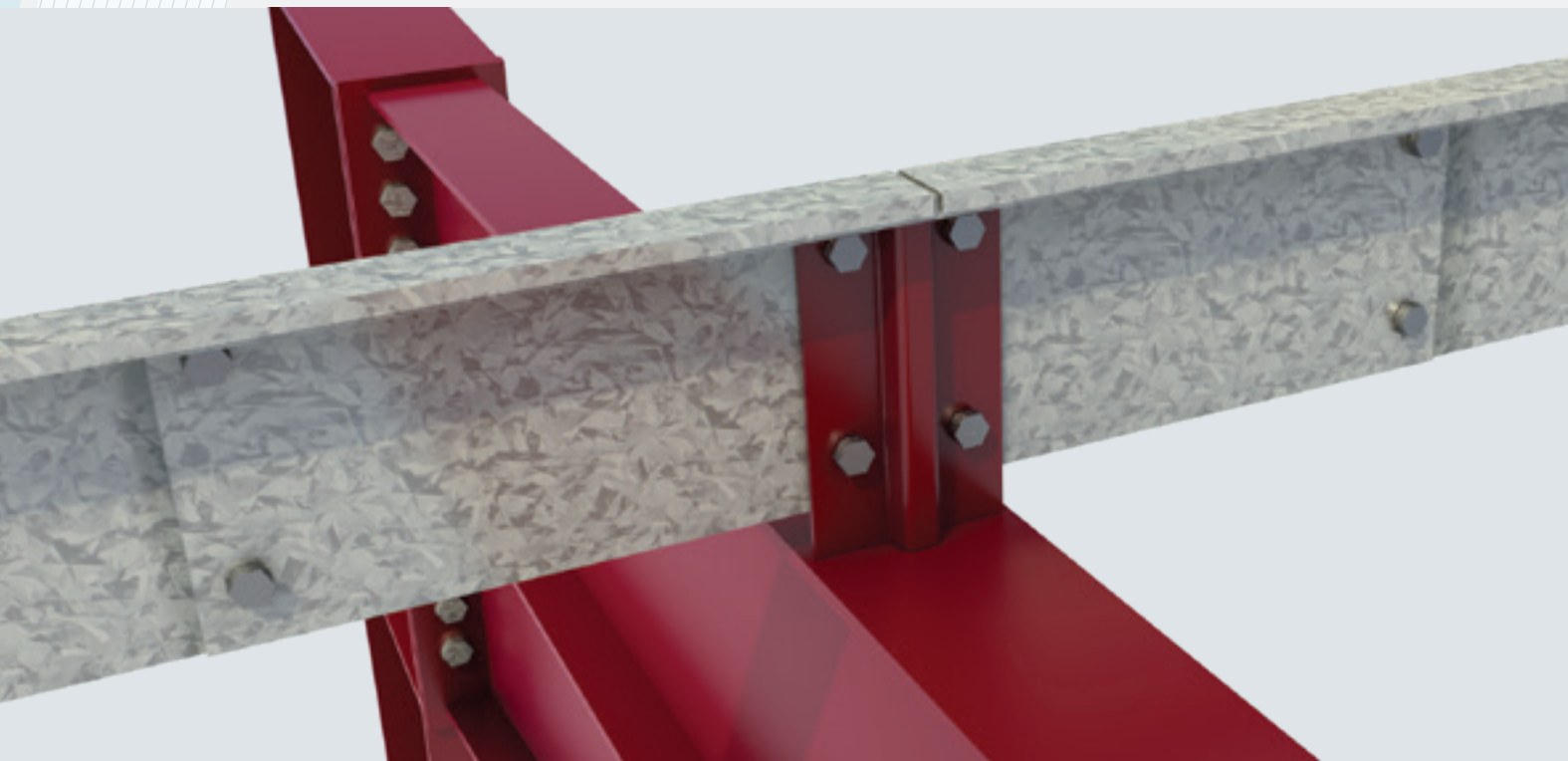

Sleeve system layouts below show hole configurations and sleeve details around the connection.

Our standard hole sizes are:

- All holes 18mm diameter to suit M16 (grade 8.8) bolts.
- All incoming accessories to be 18mm diameter
- Clearance from top of rafter / column to underside of purlin / rail = 7mm.

For the layouts see page 22.

Sleeved system (mm)

A	123	143	173	203	233	263	303	353	403
B	35	45	50	50	50	50	50	50	50
C	53	53	73	103	133	163	203	253	303
D	42	52	57	57	57	57	57	57	57
E	175	245	295	345	395	445	495	545	595
F	38	48	53	53	53	53	53	53	53
G	524	624	724	824	924	1024	1124	1224	1324

Heavy end bay sleeved system (mm)

A	143	173	203	233	263	303	353	403
B	45	50	50	50	50	50	50	50
C	53	73	103	133	163	203	253	303
D	52	57	57	57	57	57	57	57
E	245	295	345	395	445	495	545	595
F	48	53	53	53	53	53	53	53
G	624	724	824	924	1024	1124	1224	1324
H	774	950	1100	1250	1450	1650	1924	2174
J	320	408	483	558	658	758	895	1020

Single span layout

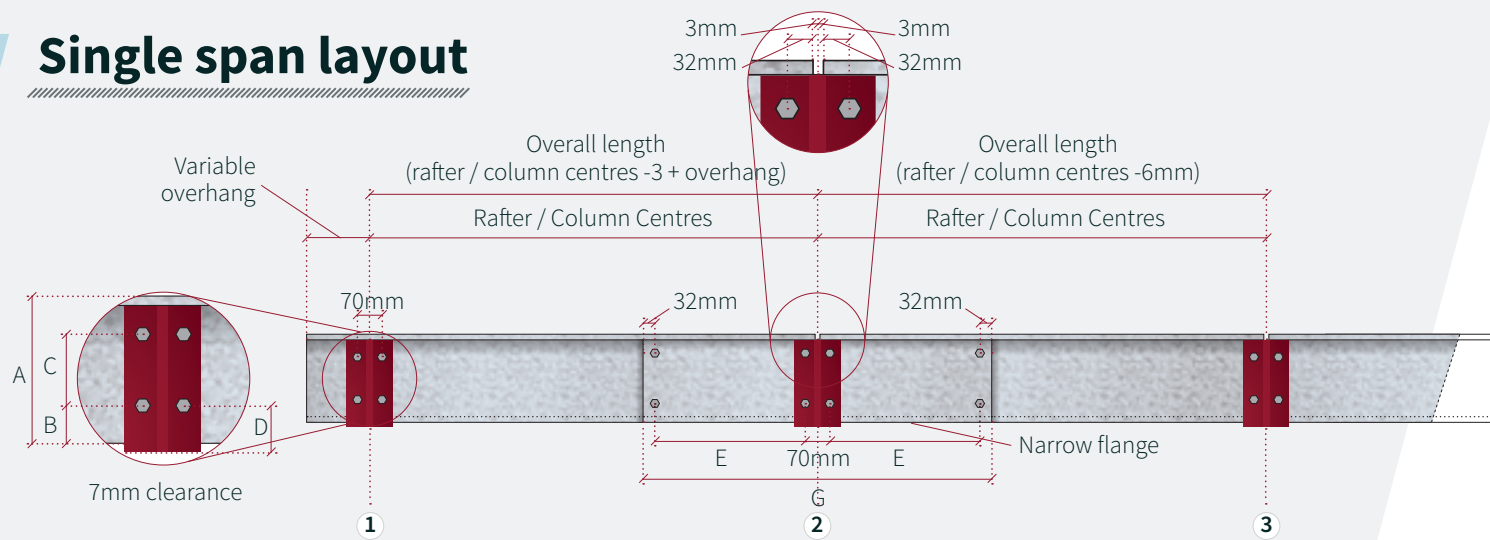

Heavy end bay – single span layout

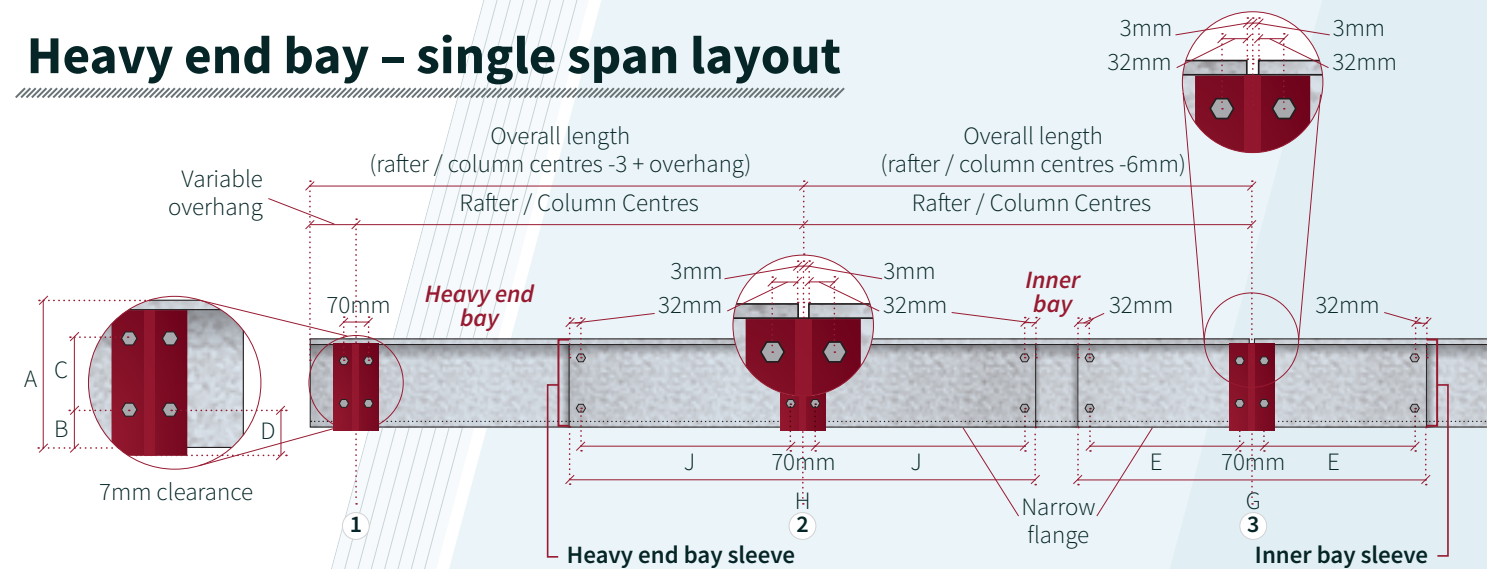

Double span layout

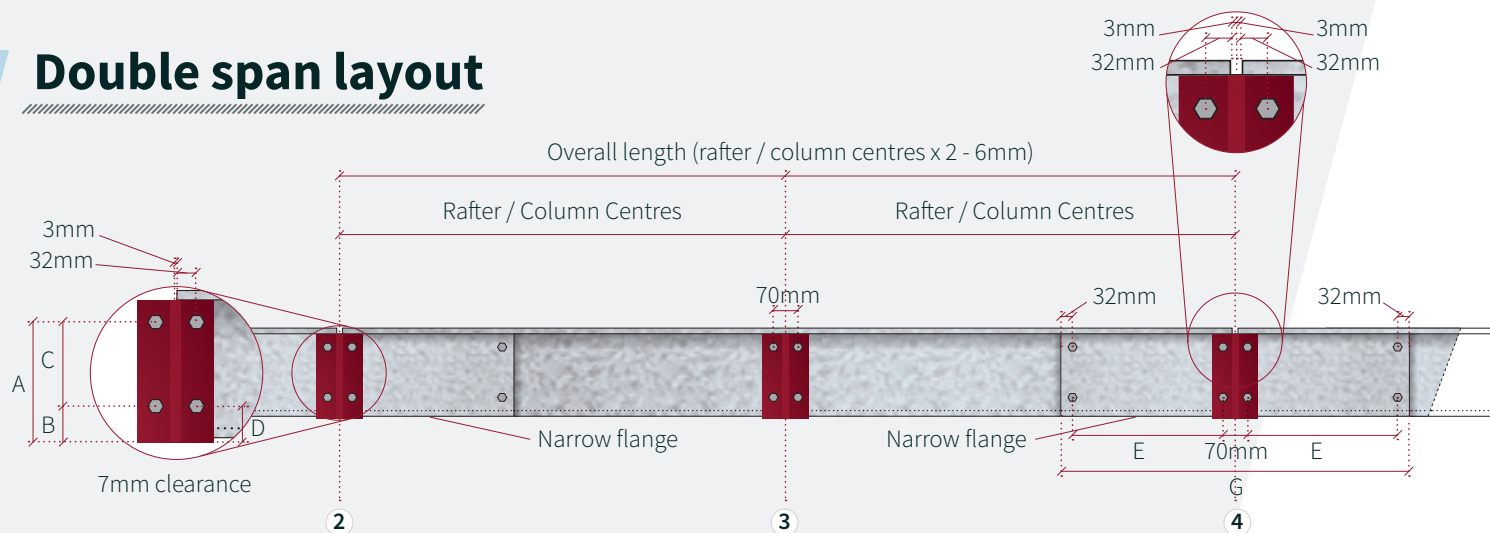

Heavy end bay – double span layout

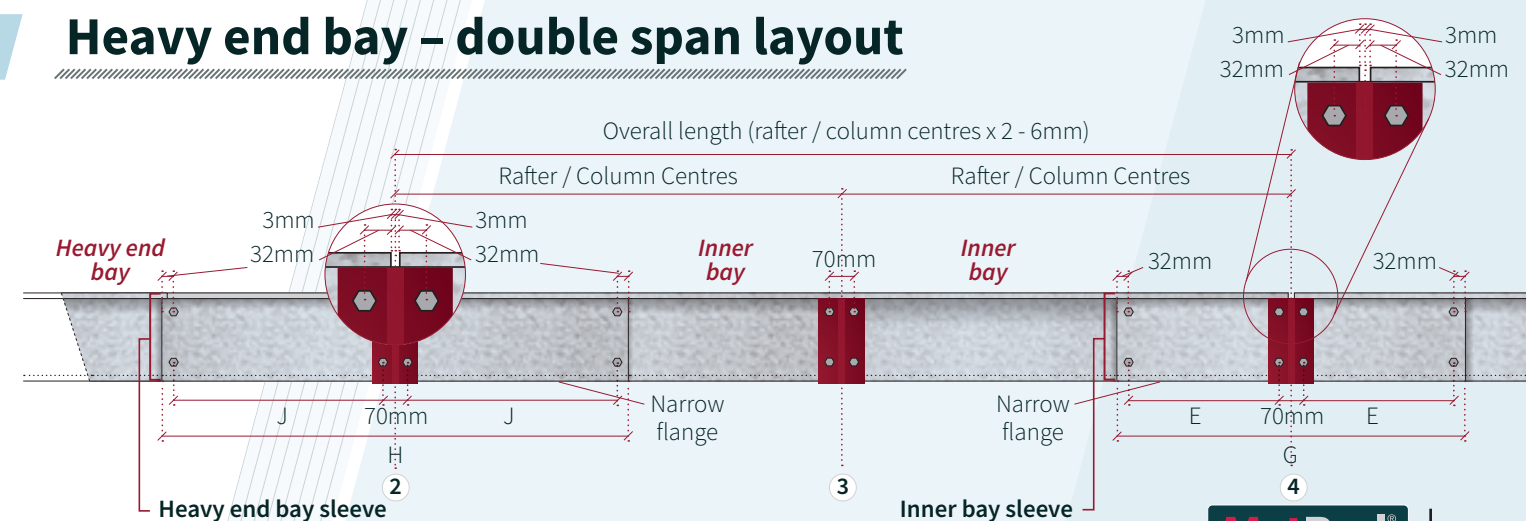

BOLT ON CLEATS

To bolster the full range of Standard Bolt On Cleats (BOC) illustrated below, CMF also offer a multi holed range for 203 – 263 deep sections (MBOC) which enable optimisation of the Purlins or Rails in adjacent bays. All the below are for use with standard loadings, for abnormal loading (steep, tiled and high wind loads) please consult our technical department. **Finish = Post Galvanised, alternatives can be provided upon request. Seek advice from CMF regard finish / lead time on alternatives. All cleats grade S355JR. All bolts grade 8.8 minimum.**

STANDARD BOLT ON (BOC)

Section Ref	A	B	T	Hole ϕ	H
123	53	42	6	18	120
143	53	52	6	18	130
173	73	57	6	18	155
203	103	57	6	18	185
233	133	57	8	18	215
263	163	57	8	18	245
303	203	57	10	18	285
353	253	57	10	18	335
403	303	57	10	18	385

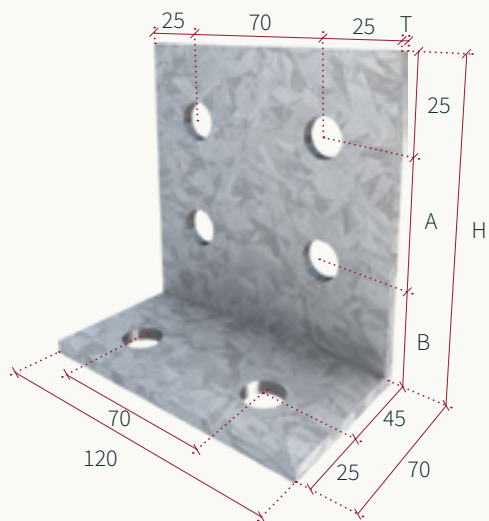

203 MULTI HOLED BOLT ON (MBOC - 203)

18mm diameter holes

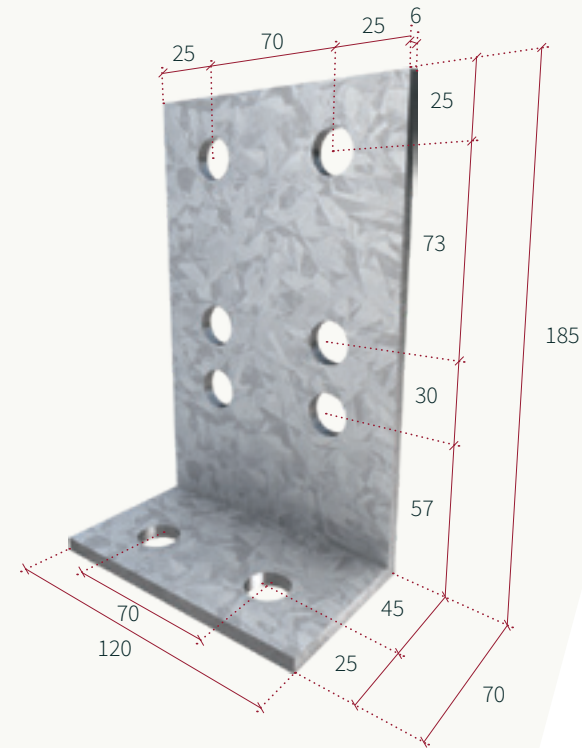

233 MULTI HOLED BOLT ON (MBOC - 233)

18mm diameter holes

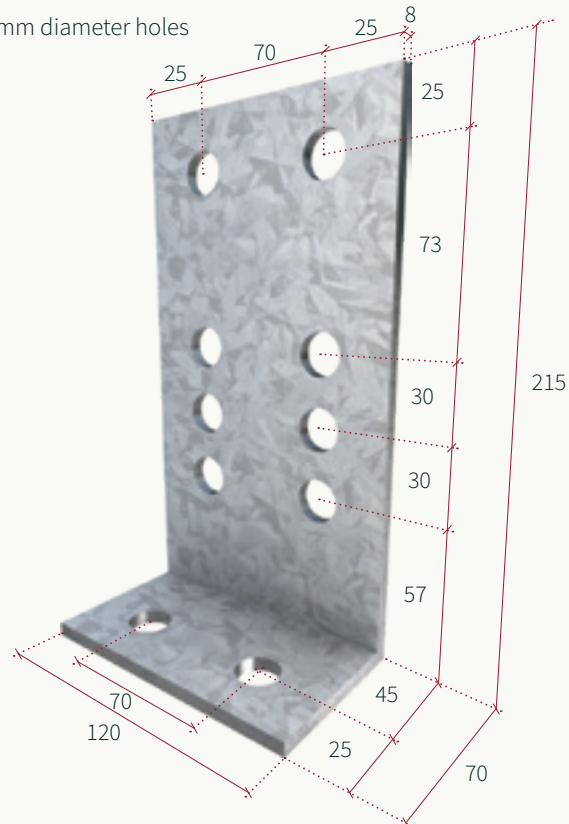

263 MULTI HOLED BOLT ON (MBOC - 263)

18mm diameter holes

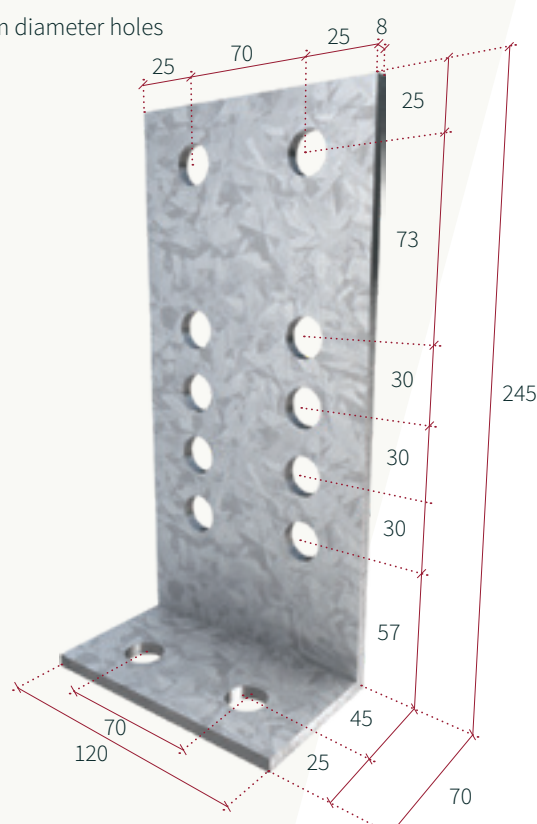

WELD ON CLEATS

As an alternative to our Bolt On Cleats CMF also offer a Weld On Cleat (WOC), mirroring the bolted range. The Multi Holed Weld On Cleat (MWOC) suits 203 – 263 deep sections which enable optimisation of the Purlins or Rails in adjacent bays. All the below are for use with standard loadings; for abnormal loads (steep, tiled and high wind loads) please consult our technical department. **Finish = Black Raw Steel - grade S355JR. All bolts grade 8.8 minimum.**

STANDARD WELD ON

Section Ref	A	B	T	Hole ϕ	H
123	53	42	6	18	120
143	53	52	6	18	130
173	73	57	6	18	155
203	103	57	6	18	185
233	133	57	8	18	215
263	163	57	8	18	245
303	203	57	10	18	285
353	253	57	10	18	335
403	303	57	10	18	385

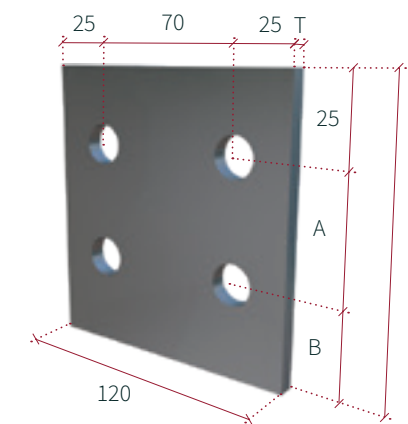

203 MULTI HOLED WELD ON (MWOC - 203)

18mm diameter holes

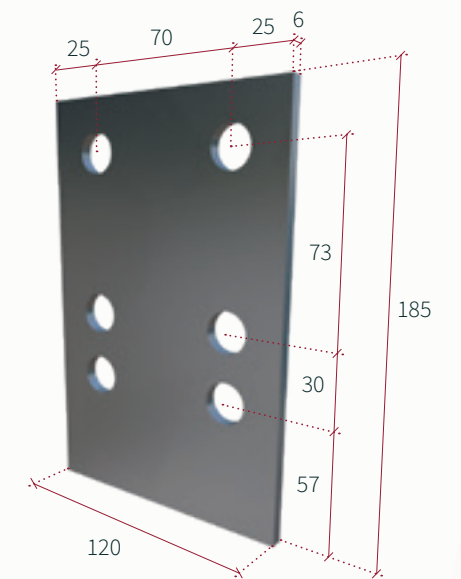

233 MULTI HOLED WELD ON (MWOC - 233)

18mm diameter holes

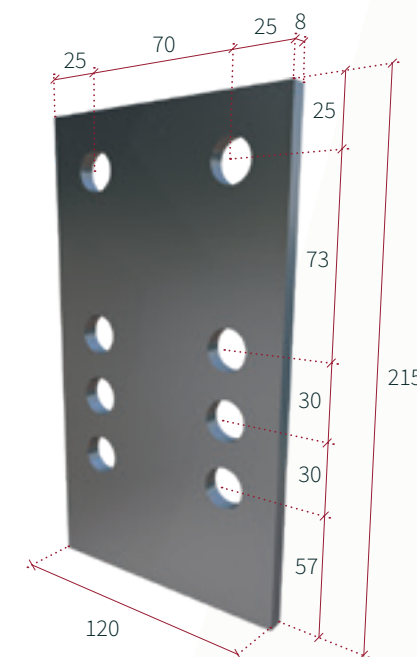

263 MULTI HOLED WELD ON (MWOC - 263)

18mm diameter holes

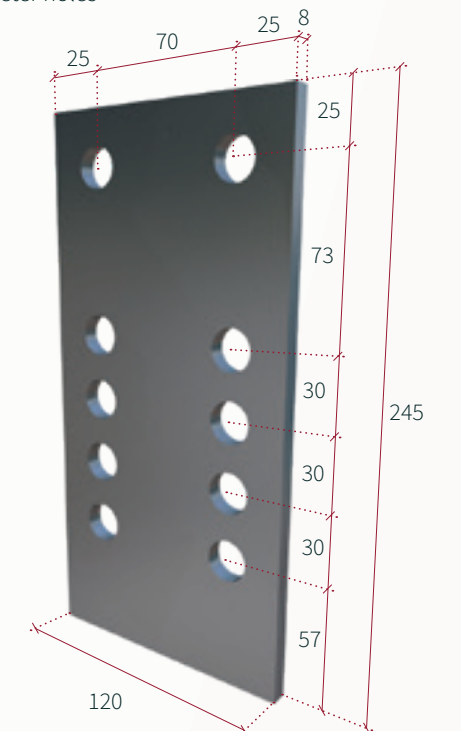

PROFILED CLEATS

CMF have designed and tested a range of 4mm thick profiled cleats (PSC), in conjunction with the Steel Construction Institute (SCI), with the following dimensions and hole arrangements. Fold in plate produces a 22mm overall ridge depth.
Finish = Black Raw Steel - grade S355JR All bolts grade 8.8 minimum.

173 PROFILED CLEAT (PSC-173)

18mm diameter holes - 4mm thick plate (out of 140 wide plate)

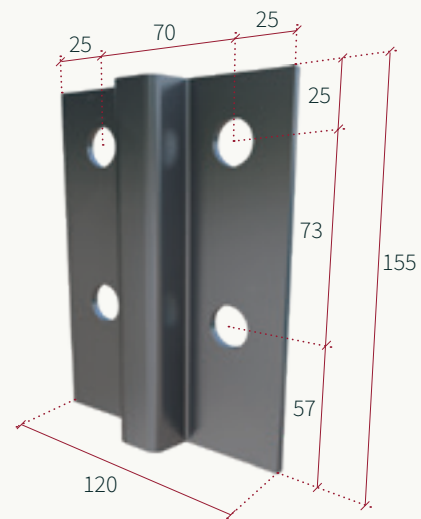

203 PROFILED STOOLED CLEAT (PSC - 203)

18mm diameter holes - 4mm thick plate (out of 140 wide plate)

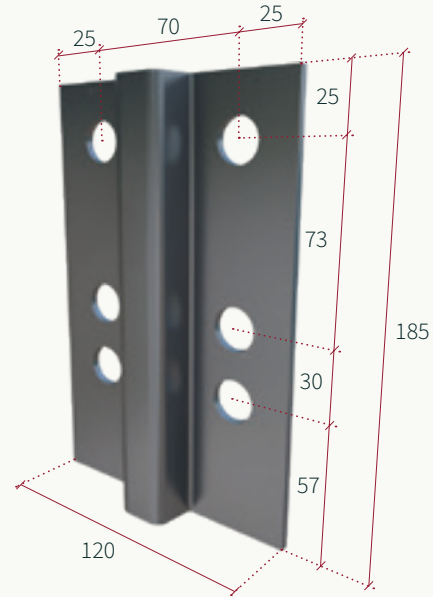

233 PROFILED STOOLED CLEAT (PSC - 233)

18mm diameter holes - 4mm thick plate (out of 140 wide plate)

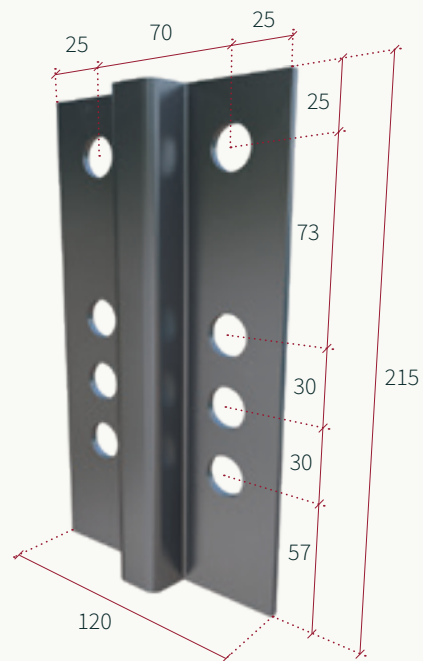

263 PROFILED STOOLED CLEAT (PSC - 263)

18mm diameter holes - 4mm thick plate (out of 140 wide plate)

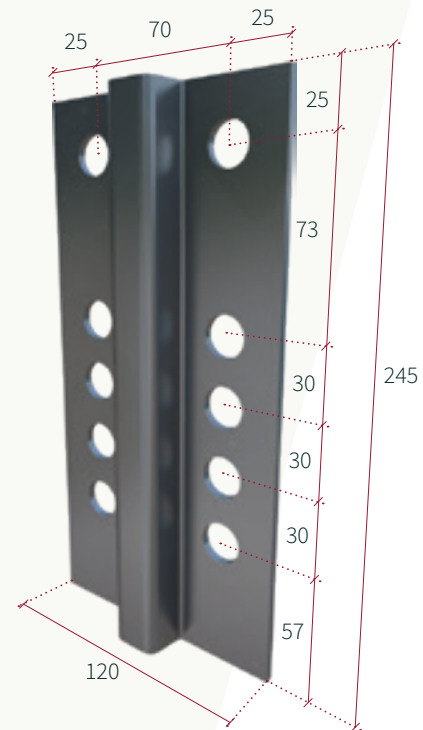

Case Study

PROJECT

Dirft III (Davenport International Rail Freight Terminal).

TONNAGE

112 tonnes including accessories.

PURLIN SYSTEMS

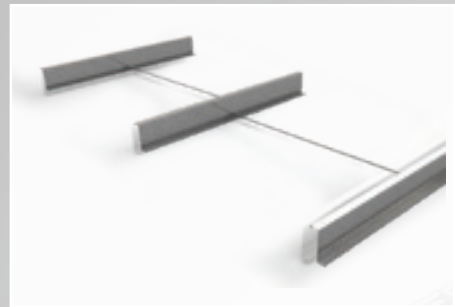

ANTI-SAG & STRUTTING 32

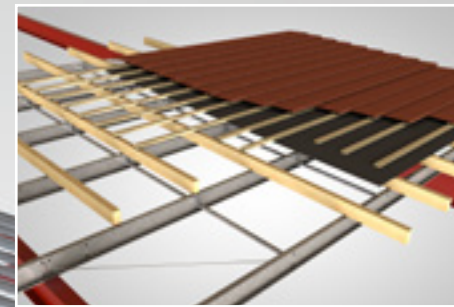

TILED ROOF 40



CLADDING RESTRAINT 39

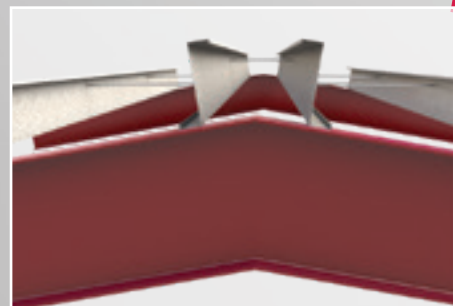
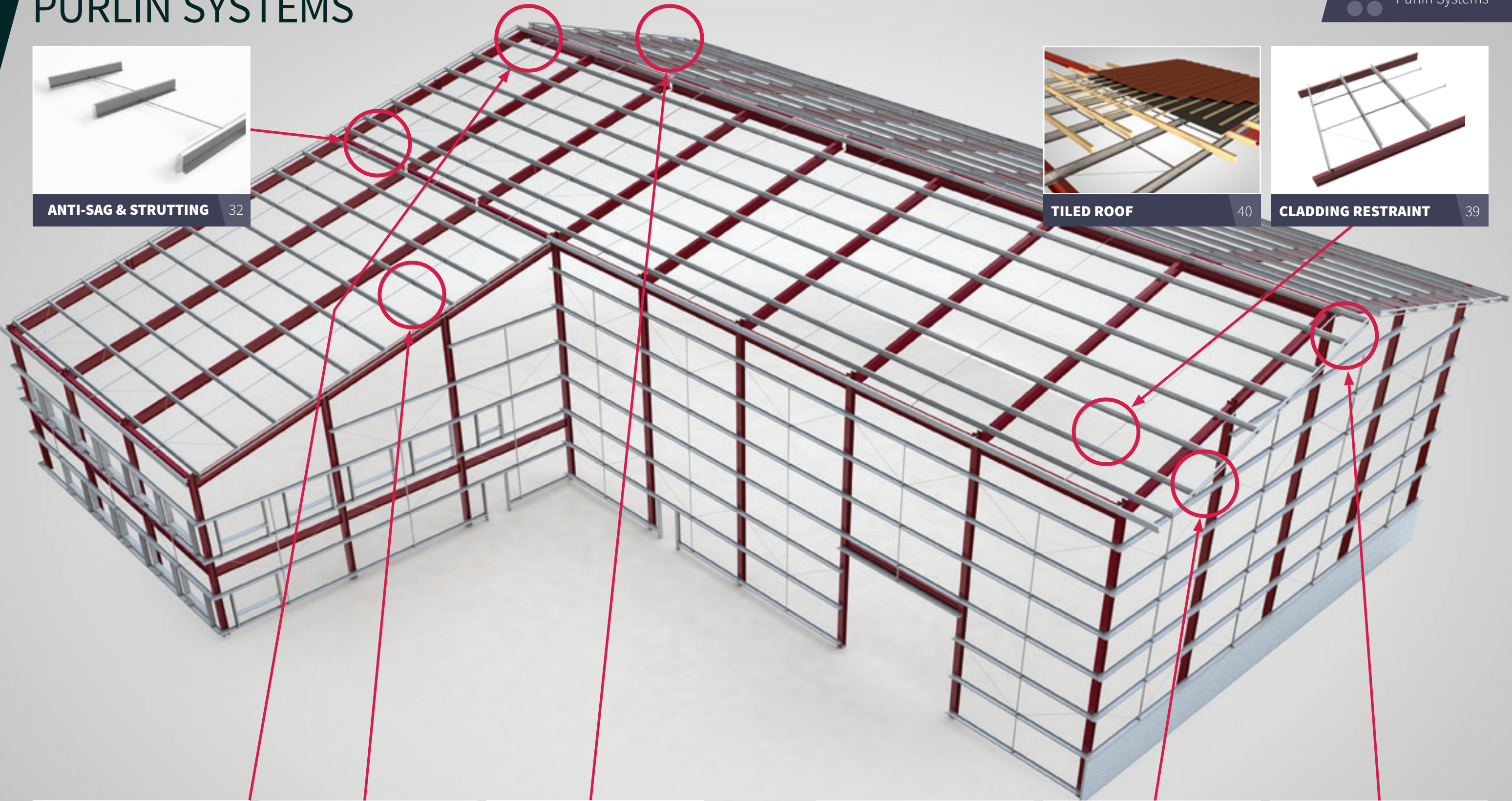

APEX TYING 33

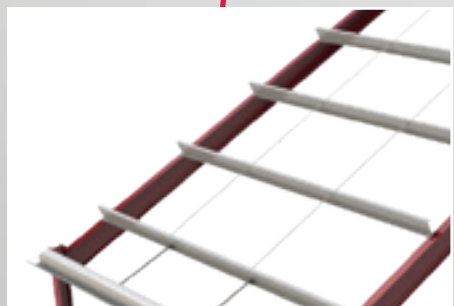

LONG ROOF SLOPES 35

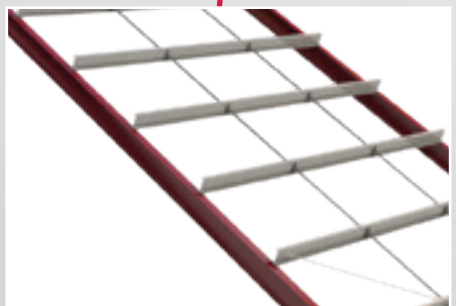

STEEP ROOF SLOPES 35



BARREL ROOF 36

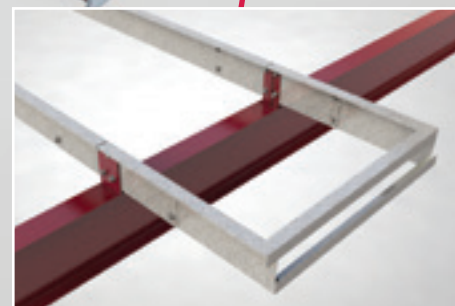

CANTILEVERS 37

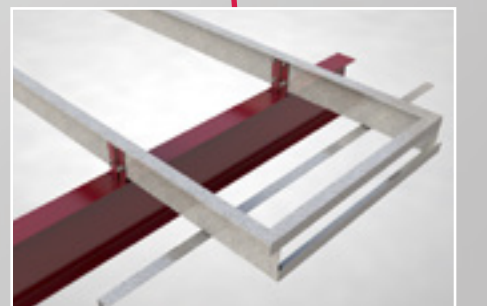

CLEADERS 38

ANTI SAG & STRUTTING REQUIREMENTS

ANTI-SAG PURLIN TIES (SPEED-FIX) - 123 DEPTH TO 263 DEPTH ONLY

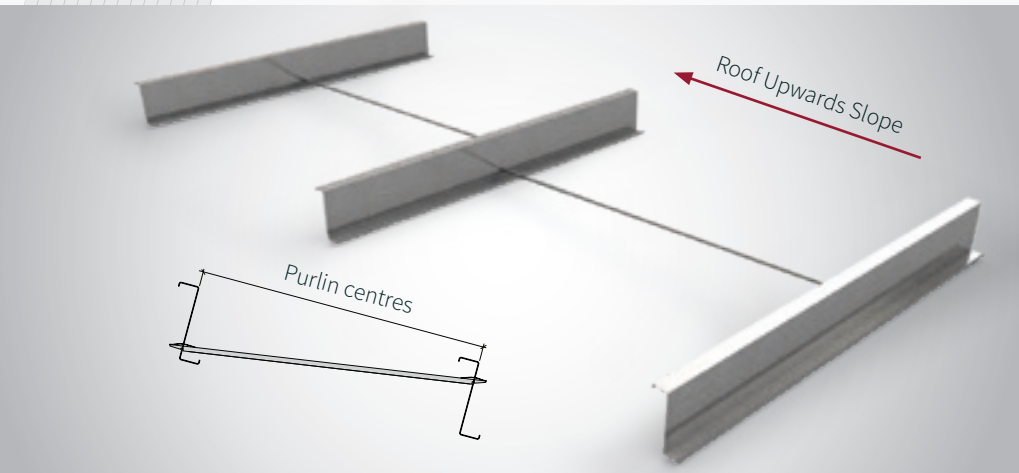

Anti-Sag details are required to provide lateral restraint to purlin members. Most typical spans can be achieved without either the speed-fix ties or struts. However, where spans are large, or loading necessitates (e.g. wind reversal), restraints may be required – for minimum numbers see table below.

Speed-fix type purlin ties shown left may be only used on purlin system depths from 123 to 263. Deeper sections will require the purlin strut restraint detail as shown below.

Additional restraints may also be needed where cladding does not restrain.

ANTI-SAG PURLIN STRUTS

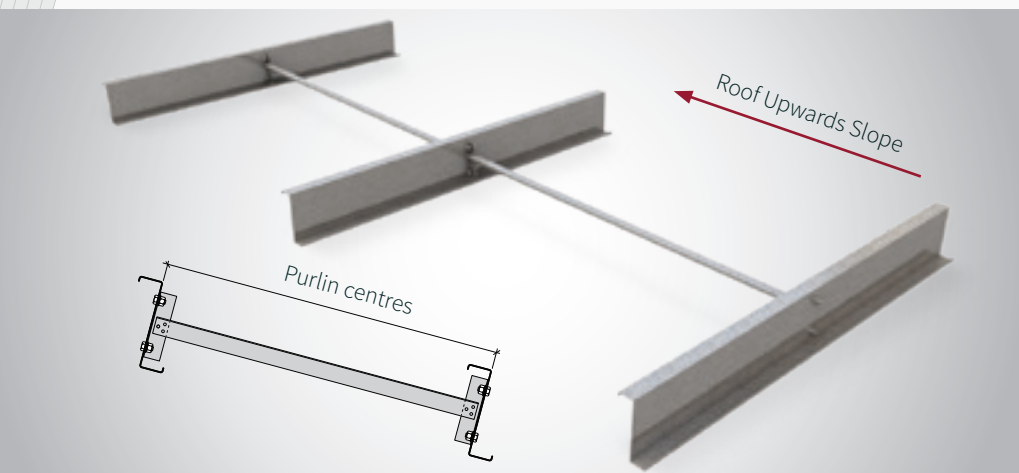

On purlin depths greater than 263mm, the strutting detail supersedes the speed-fix tie. This detail provides additional restraint, beyond that provided by the standard tie.

Additional consideration must be taken on atypical roof geometries such as long roof slopes, steep slopes, tiled roofs and mono-pitches – please refer to the specific requirements highlighted on the relevant pages of this manual.

APEX TYING

Apex tying rules are in line with the standard anti-sagging requirements and provide restraint to the purlin pair at the roof apex position. Where ties or struts are required on the general purlin centres, a minimum of the same detail is to be utilised at the apex location. Additionally, apex ties should be used on all purlin spans greater than 6.1m.

APEX SPEED-FIX TIE

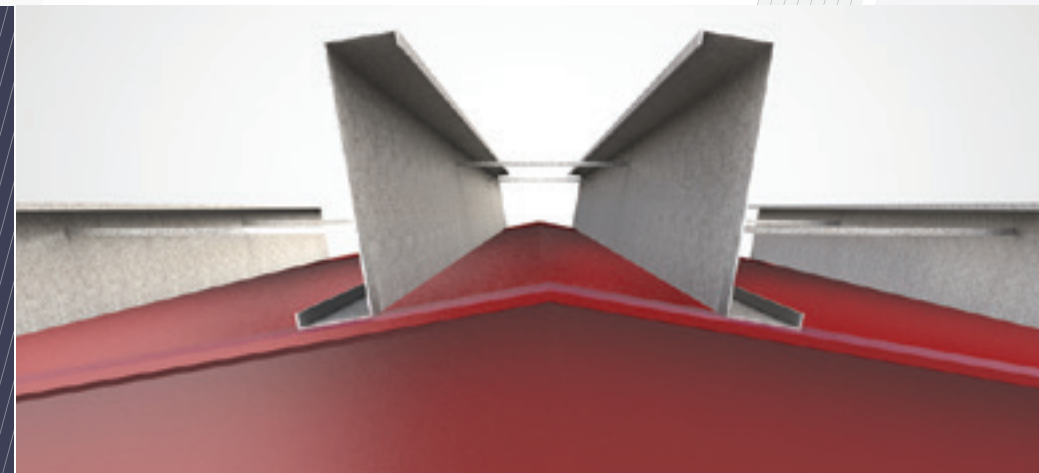

See 'Minimum Apex Tying Requirements' table below.

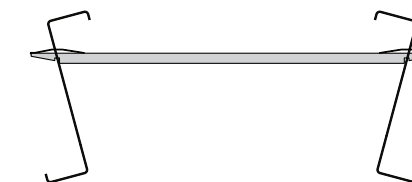

APEX STRUT

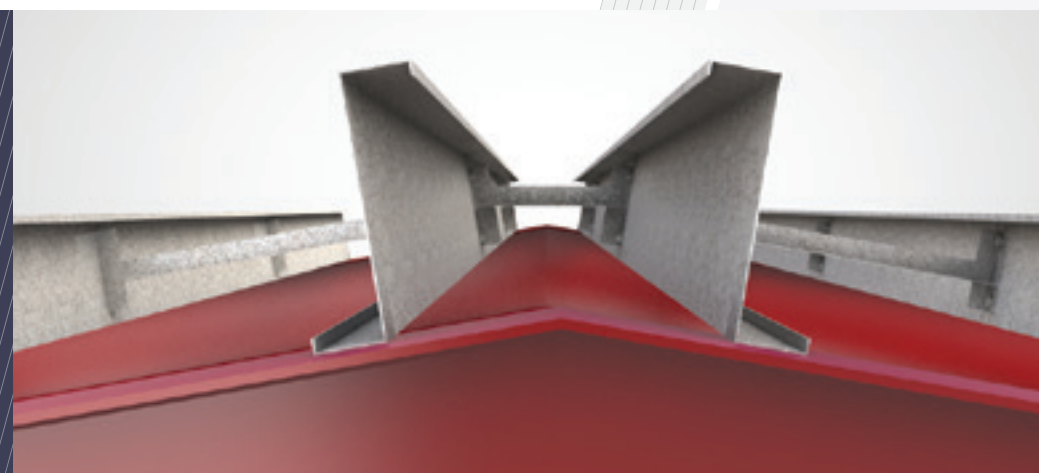

See 'Minimum Apex Tying Requirements' table below.

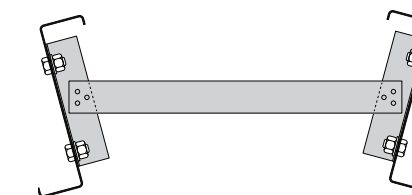

MINIMUM STRUTTING RULES

The following table provides the minimum strutting requirements for the various purlin system sizes. For further information please refer to the MetPurl software, available online, or load span tables enclosed. For clarity, detailers are to adopt the most conservative strutting requirement of the MetPurl software results versus the adjacent table.

Roof Slope	MetPurl Section (mm)	Bay centres for minimum allowable speed fix or strut anti sag quantities	
		0 restraint	1 or more restraints
0° - 25°	123	5.8m	Spans greater than those specified, utilise MetPurl software or load span tables provided
	143	6.2m	
	173	6.7m	
	203	6.9m	
	233	7.2m	
	263	7.6m	
	303	8.2m	
353	8.2m		
403	8.2m		
25° - 60°	For roof slopes within this range, angle struts must be used. MetPurl software should be utilised for quantities		
> 60°	For roof slopes greater than 60°, Purlins are to be designed as a side rail system		

Notes:

- On roof slopes greater or equal to 25°, 2.4m+ purlin spacings or heavy roof systems, anti-sag angle struts must be used on all section depths.
- Temporary propping or spacer bars may be required when no anti-sag solutions are adopted during construction and installation of roof system.
- Detailer to always adopt apex ties and eaves struts.
- Angle eaves brace always required when adopting speed-fix anti-sag.
- Apex ties to align with anti-sag system (i.e. continuous).
- For tiled roofs Anti-sag purlin struts must be used.

MINIMUM APEX TYING REQUIREMENTS

Apex details	Scenario					
	Restraining cladding	Non-restraining cladding	Roof slope <= 25	Roof slope > 25	Purlin system < 300mm	Purlin system ≥ 300mm
Apex Speed-Fix Tie	Y		Y		Y	
Apex bolted strut	Y	Y	Y	Y	Y	Y

Notes:

- Apex restraint details should be installed on all purlin spans greater than 6.1m.
- Detailer to always adopt apex ties and eaves struts.
- Apex ties to align with anti-sag system (i.e. continuous).
- For tiled roofs Apex bolted struts must be used.

Apex restraint details should be installed on all purlin spans greater than 6.1m.

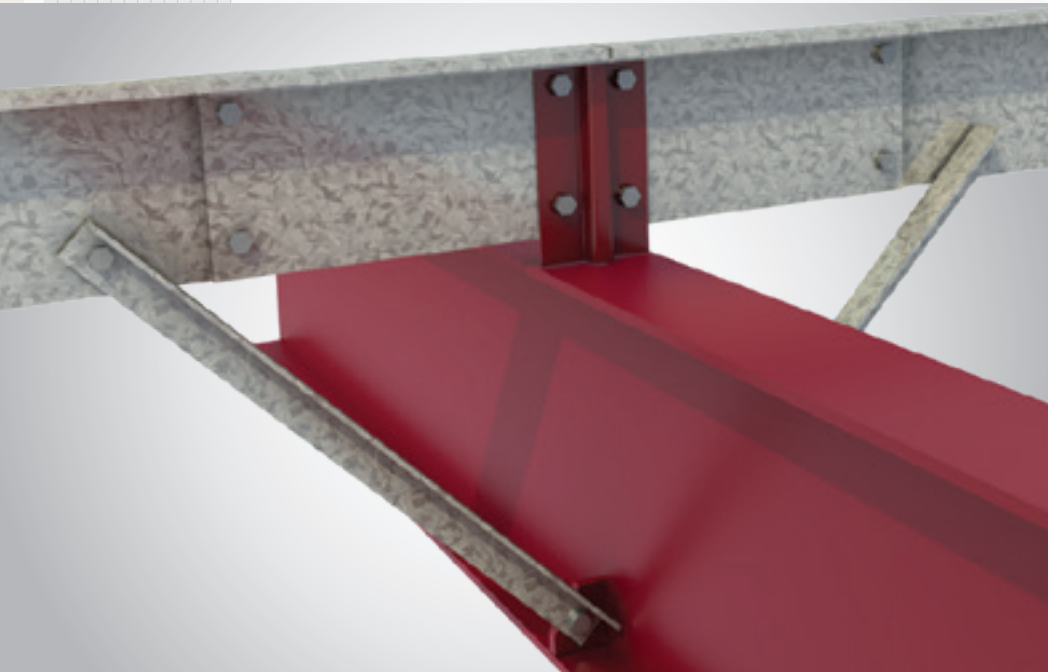

Rafter / Column stays are provided in line with the Structural Engineers' requirements for lateral restraint of the primary rafters or columns.

This is specified in accordance with the relevant clauses from either BS EN 1993-1-1 or BS 5950-1 and provide restraint to the lower flange of the primary rafter or inner flange of the column.

The stay length may vary with the primary section depth to provide the required angle. The stay should be angled at circa 45 degrees as shown in the diagrams below.

RAFTER STAY OPTIONS

Two stay sizes are available from the MetPurl range, where the suitability of each is determined by the primary steelwork designer. Typical sizes are outlined in the following table:

Stays sizes	Leg 1	Leg 2	Gauge
Option 1	45mm	45mm	2mm
Option 2	60mm	60mm	2mm

Suitability of each is designated by the primary steel design engineer based on restraint requirements in BS 5950-1 or BS EN 1993-1-1.

TYPICAL DETAIL

Stay fixed to sleeve

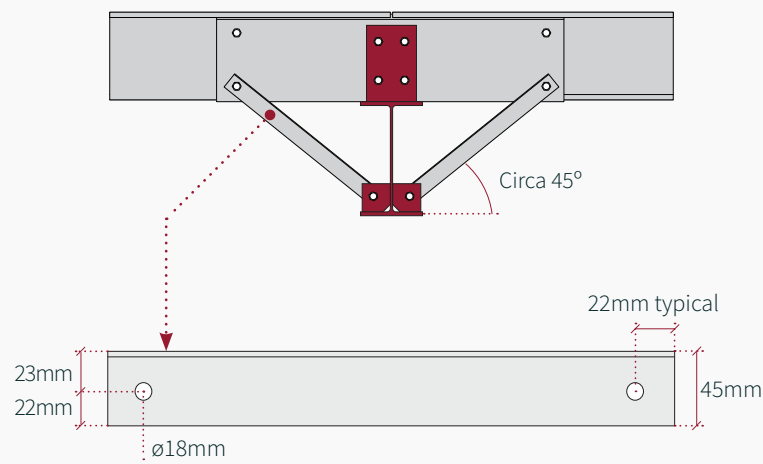

NOTE: Rafter / column stay size for each detail is determined by design.

Deep rafter stay setting out

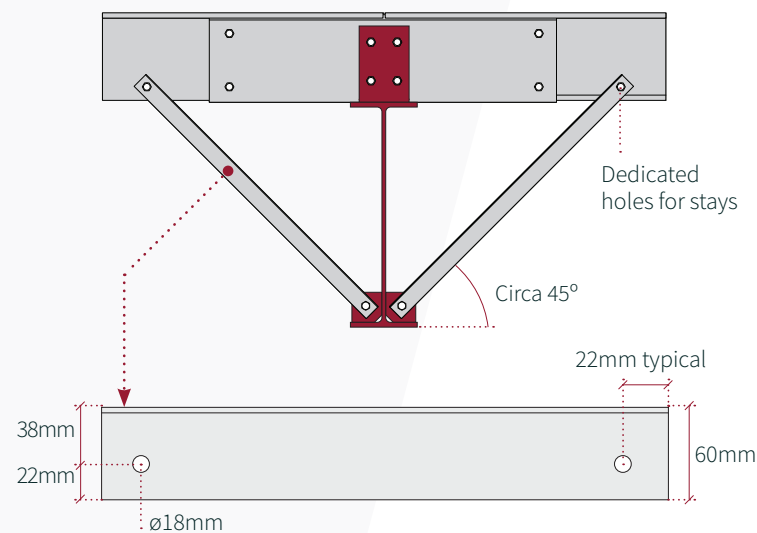

LONG ROOF SLOPES

For long roof slopes greater than 20m, additional diagonal tie wires (DTWs) are required to carry the increased load down the slope. A minimum of one line of lateral restraint is required, evenly spaced across the bay width. Inclusion of apex ties and eaves struts are recommended. Anti-sag purlin strut must be utilised at DTW location. See page 32 and 33 for further guidance.

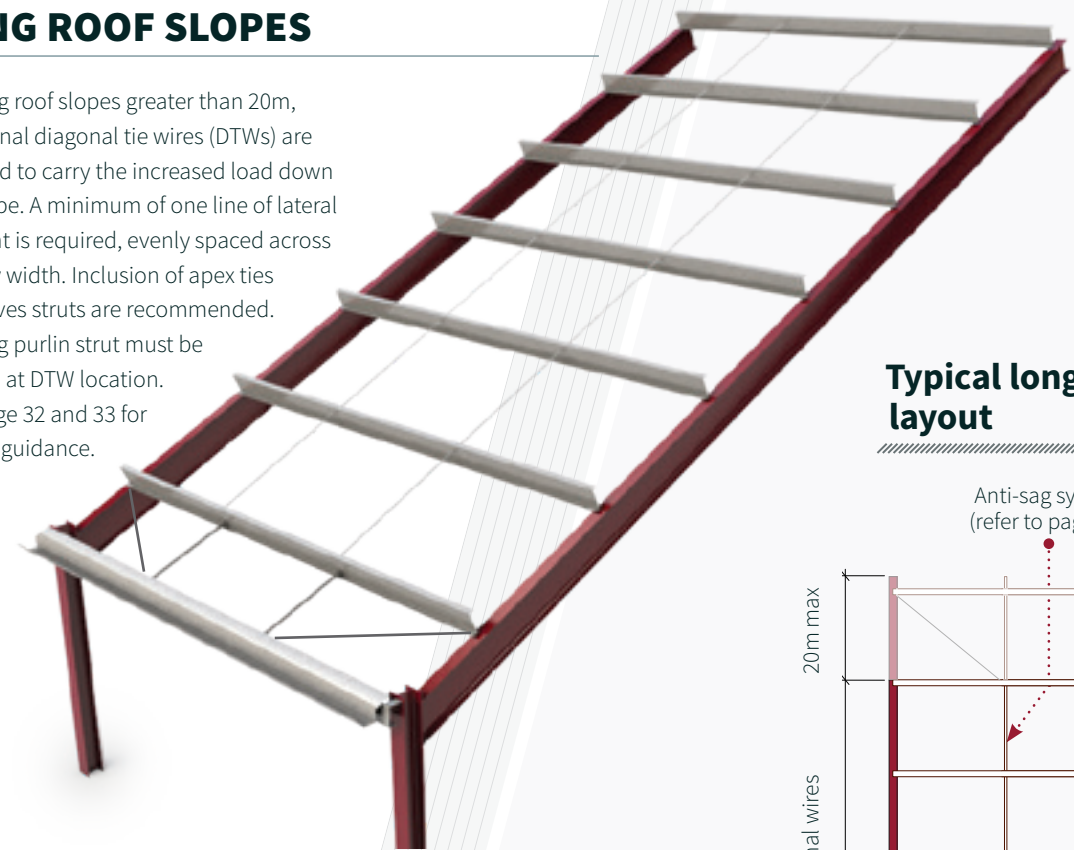

Typical long roof slope layout

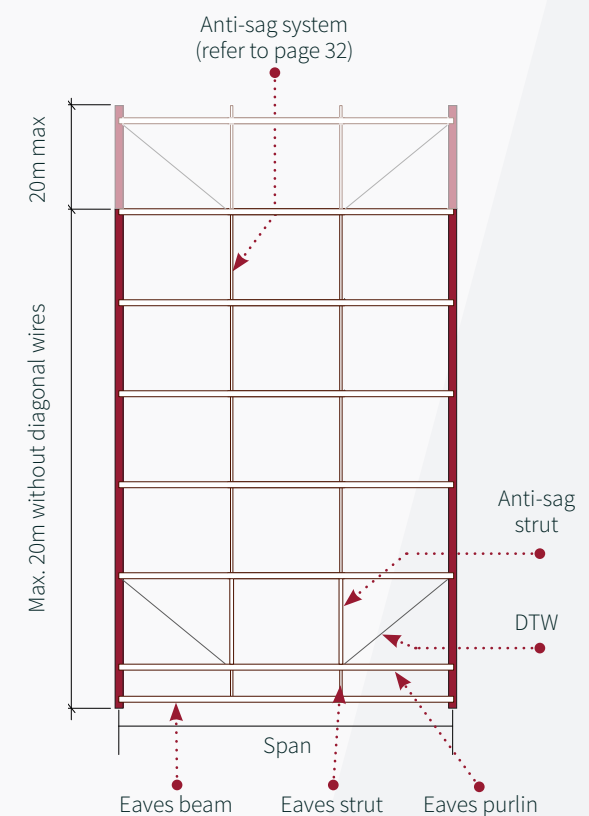

Diagonal Tie Wire (DTW) connection detail

Diagonal tie wire (DTW) connects to the lowest holes in rafter cleats.

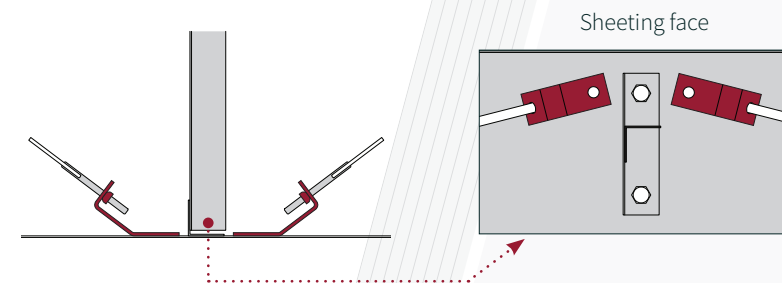

STEEP ROOF SLOPES

For standard design parameters roof slopes are limited to 25 degrees. Once this value has been surpassed additional consideration within the purlin design is required to carry the down-slope load component. The following table outlines typical slope limits and design methodologies.

Roof Slope	Design method
0 to 24.9 degrees	Standard rules*
25 to 59.9 degrees	Consult MetPurl software
60+ degrees	Consult MetPurl Software, considered as a side rail

*For clarity, detailers are to adopt the most conservative strutting requirement of the MetPurl software results versus the brochure guidance (see page 32).



BARREL ROOF

Barrel roofs are another example of one of the more unusual, and aesthetically pleasing roof variations. The MetPurl purlin range and associated ancillaries are a perfect fit for these roof geometries and provide an efficient solution for a barrel roof design.

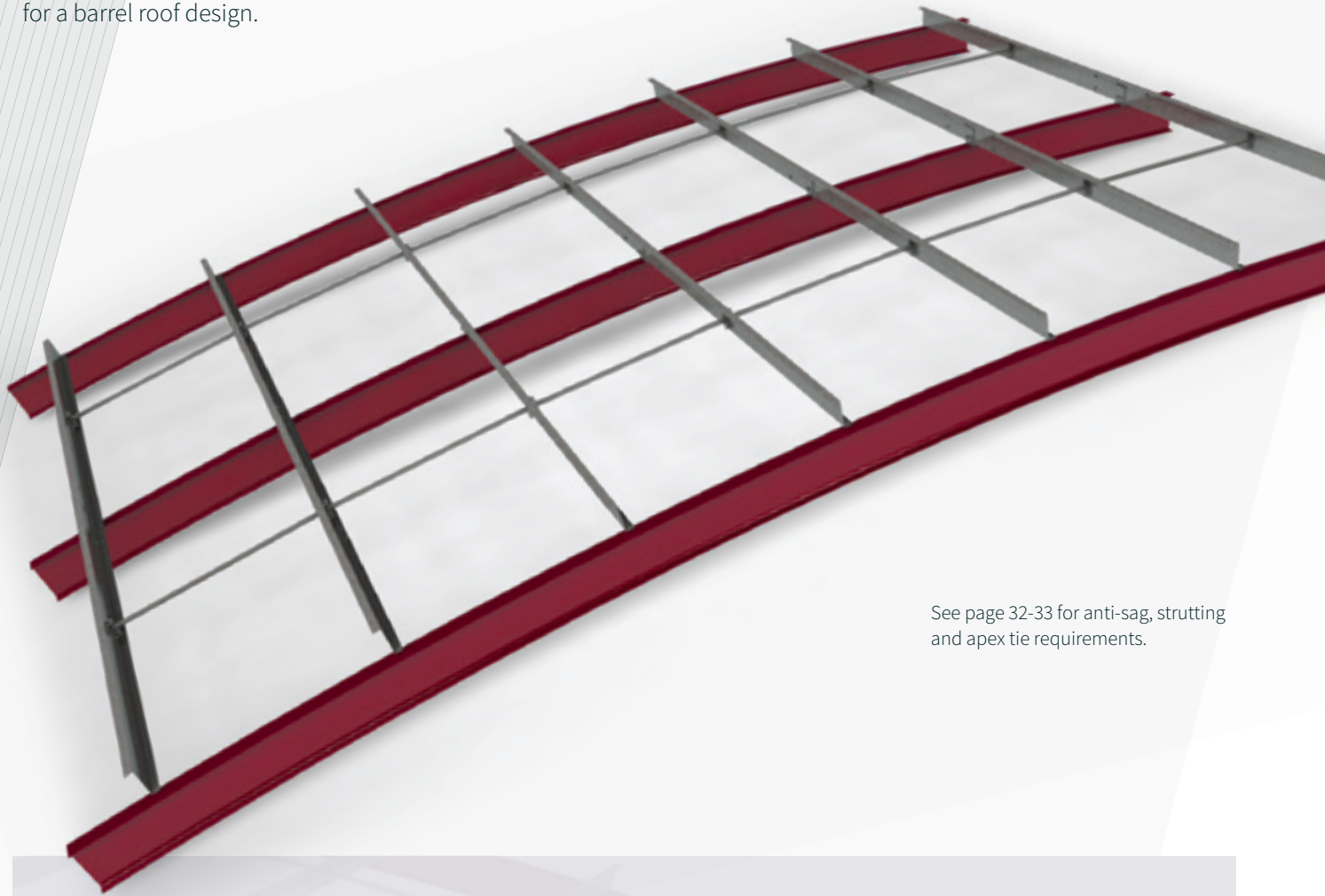

See page 32-33 for anti-sag, strutting and apex tie requirements.

TRIMBLE TEKLA STRUCTURES



To assist with the detailing and modelling of these more complex barrel roof forms, specific barrel roof macros are available for use with the CMF MetPurl range within Trimble's Tekla Structures.

This speeds up the design process and enables efficient application of the MetPurl components.

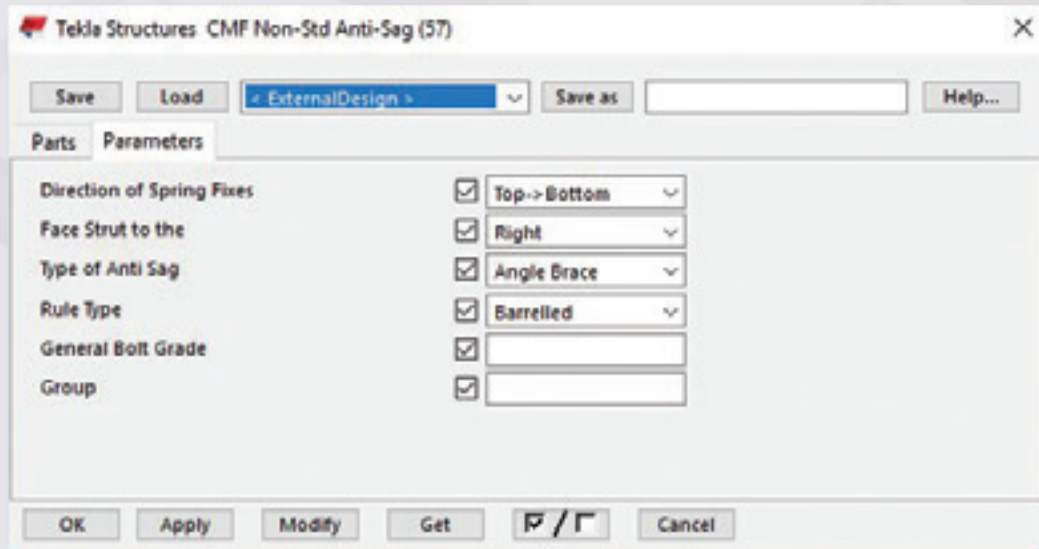

CANTILEVERS

The MetPurl system can be used to form a range of structural features, including roof cantilevers and canopies. These can be achieved via continuous purlin members, or by using the sleeve components to extend purlin lengths, as shown below, over gable ends.



Sleeved purlin cantilever detail with cleader rails

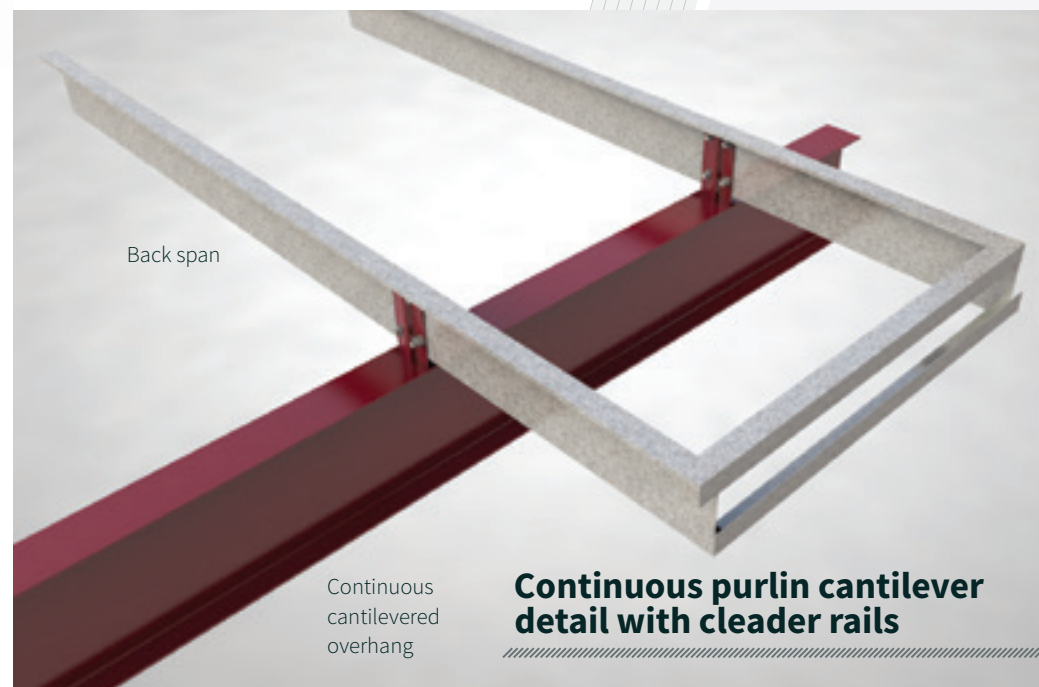

Continuous purlin cantilever detail with cleader rails

Cantilevering purlins, by their nature, require some additional consideration for stability (racking and rotation). Cantilever end of the purlin should be linked by means of cleader angles (see overleaf), and be provided with full lateral support from suitable cladding finishes.

Other more complex roof geometries may require additional restraint by design (struts and DTW system). These include barrel roofs where additional detailing is required at the overhanging ends, and mono-pitch roofs where the overhang may require tie wire bracing to support the component of the load down the slope. Roofs over 25 degrees must include additional strut and DTW systems.

Deflection is another consideration to be made when creating canopies and cantilevers using the purlin system. Span tables utilise standard deflection limits, where typically more stringent limits should be applied to cantilevers – the MetPurl software enables this additional consideration (see below for 30% guidance).

Cantilevers must be formed from a continuous purlin length, typically overhanging a maximum of 30% of the purlin backspan length (subject to design and loading).

Alternatively, the cantilever can be achieved by extending purlins beyond the end rafter bay by using the appropriate sleeve detail.

Cantilevers of various span arrangements can be calculated within the MetPurl software.

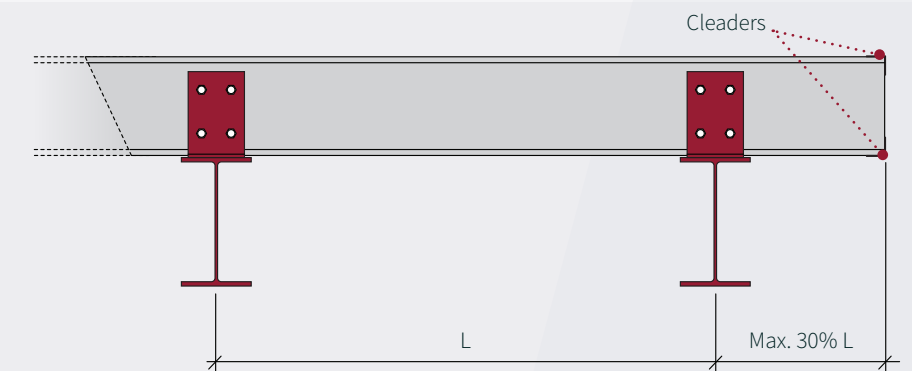

CLEADER RAILS

Where cantilevers and other secondary steel details are required, cleader rails offer additional connection positions where planes do not directly align. One of the more common examples of this is at cantilevers where

the head of the wall cladding abuts the underside of the cantilevering purlins. A cleader may be used in this position to pick up the cladding head where other restraint is not available.

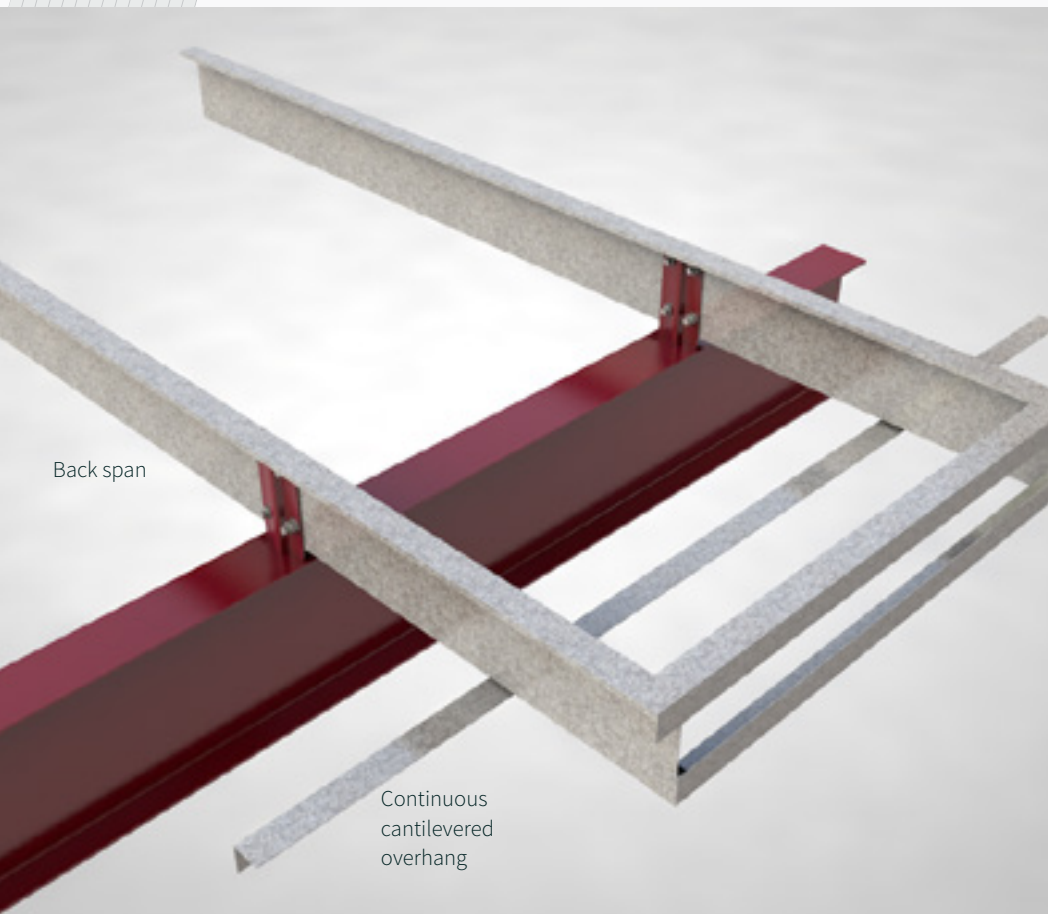

Cleaders may be installed onto the purlin members in a variety of layouts – single, double or multi-spanning between purlin ends. On purlins with smaller flanges, cleaders may need to be overlapped to form a robust joint where a continuous cleader length is required (minimum 56mm lap).

Cleaders are typically fixed to the purlin flanges, either at the cut end of the purlin or along its length to provide cladding restraint as described above.

- 45 x 45 x 2L - Z275 for spacings upto 1.8m.
- 100 x 100 x 2L - Z275 for spacings over 1.8m.
- All supplied without holes, cleader can then fix where required.
- Max length 4m.

EXAMPLE DIAGRAM

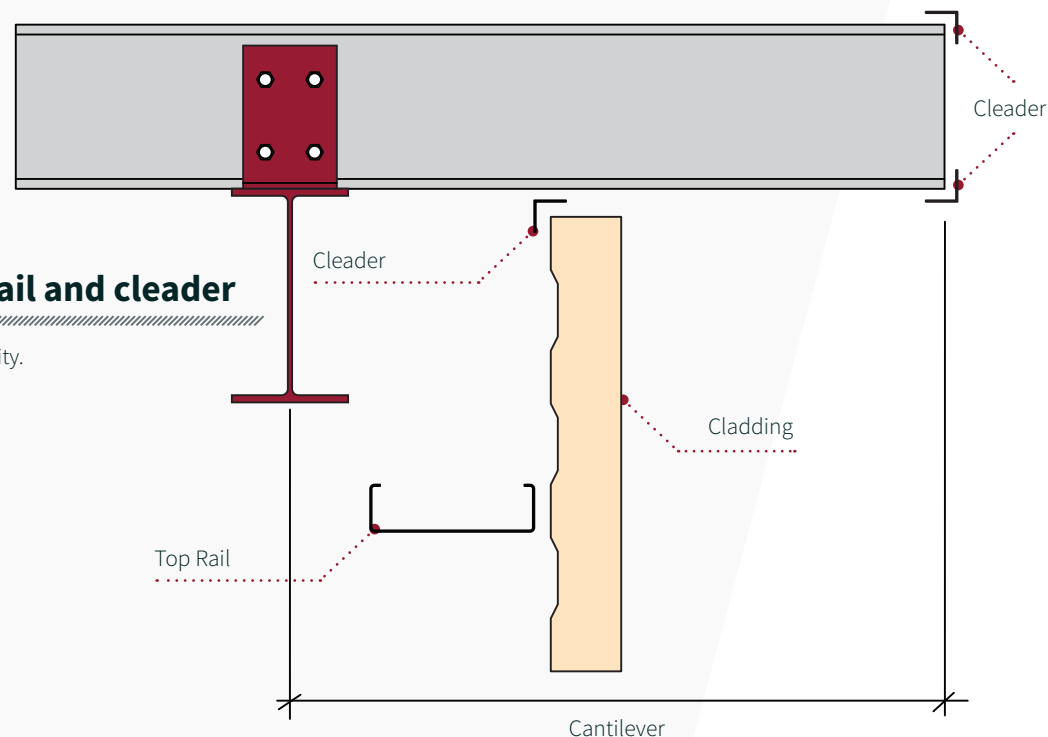

Cladding fixed to top rail and cleader

Roof and Soffit cladding omitted for clarity.

CLADDING RESTRAINT

All typical cladding systems may be used in conjunction with the MetPurl system, and more unusual finishes may also be applied where considered within the design. Typically for the most efficient purlin design, cladding should supply lateral restraint to the purlins. Not all cladding is able to supply this restraint and its capabilities should be reviewed prior to the completion of the purlin design to ensure correct restraint conditions are applied.

MetPurl's design software enables purlin design for both restraining and non-restraining cladding types.

For indicative guidance, please see the below table where typical restraint conditions are outlined. These are not exhaustive, but form initial guidance which should be confirmed against the cladding manufacturers technical information.

CLADDING TYPE	LATERALLY RESTRAINS	
Trapezoidal profiled sheet	Yes	
Insulated twin skin sheeting through fixed	Yes	
Insulated panel through fixed	Yes	
Composite standing seam cladding panels	Yes; where steel liner is fixed to purlins	
Built up flat roof	Yes; where profiled deck is through fixed	
Twin skin standing seam built up cladding with through fixed liner	Yes	
Tiled roof finishes (see overleaf)	No	

Notes:

- See MCRMA Technical Paper 12 and SCI P346 for more guidance for cladding manufacturers regarding fixing spacings and levels of restraint these provide.
- CMF recommend through fixing spacings of 350-500mm (dependant of trough spacings) to provide adequate restraint to the purlin / rails from the cladding / liner tray.
- Areas of local high wind loading should be checked by cladder as additional fixings could be required.

Horizontal Cladding Guidance:

- Built up cladding systems - utilising vertical spanning liner trays (min 0.4mm thick, min 20mm profile depth) with horizontal spanning outer sheets, only provide lateral restraint if the liner tray is positively through fixed to the purlin / rail at centres no greater than 500mm.
- Horizontal composite panels - these do not fix to the purlin / rail directly and are there for non-restraining.

TILED ROOFS

Tiled roofs are an example of cladding systems which do not typically provide lateral restraint to purlins. Tiled roofing finishes are usually a heavier dead load – MetPurl purlins are an ideal solution for carrying these loads and only require a more robust anti-sag system.

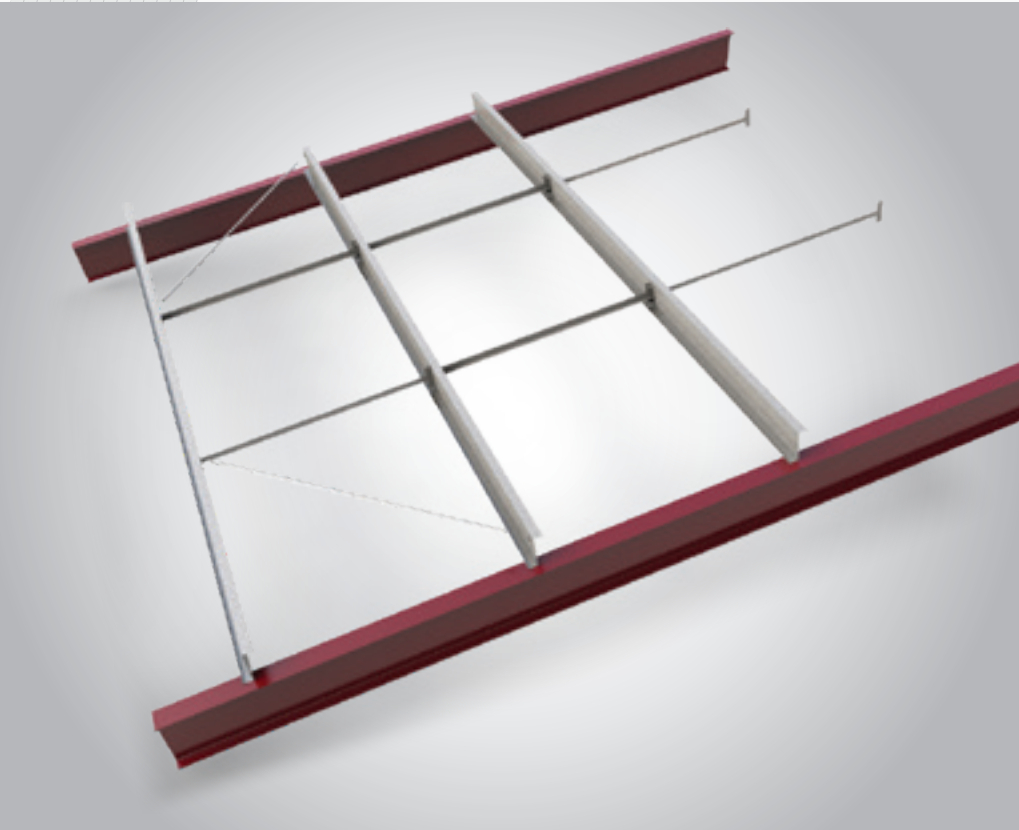

Where tiled roof finishes are present, bolted strut type purlin restraints must be utilised to ensure purlins are sufficiently laterally supported.

Timber battens or similar should be provided at regular centres perpendicular to the purlin span, evenly distributing the applied loads across purlin members.

The MetPurl design software can be used to design purlins with tiled and other similarly heavy finishes, giving requirements for purlin restraint and member specifications.

See page 32-33 for anti-sag, strutting and apex tie requirements.

DTW must be adopted on tiled roofs every 6m of roof slope.

Profiled stooled cleats (PSC) or stiffened cleats out of mild steel flat (provided by others) must be used.

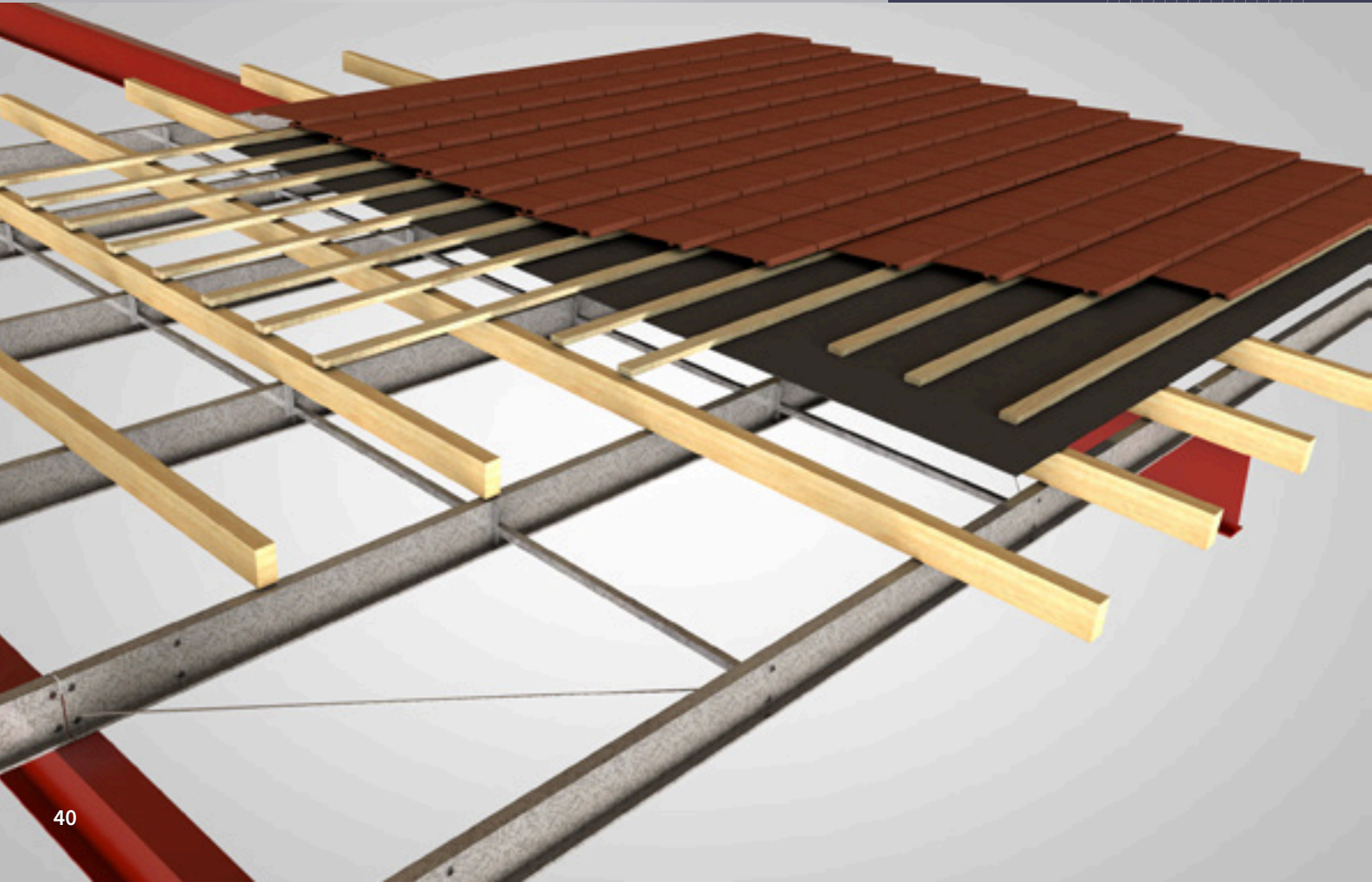

EAVES BEAMS

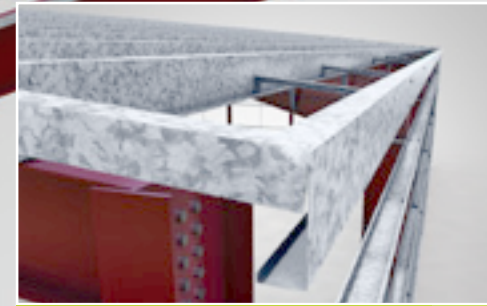

EAVES BEAMS DETAILS 42

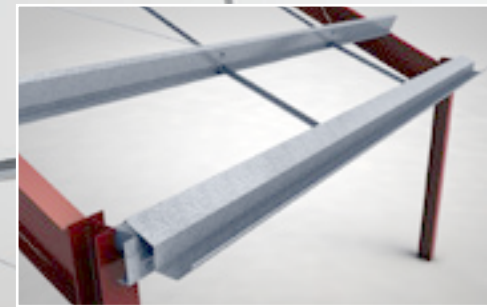

EXPOSED GUTTER DETAIL 43

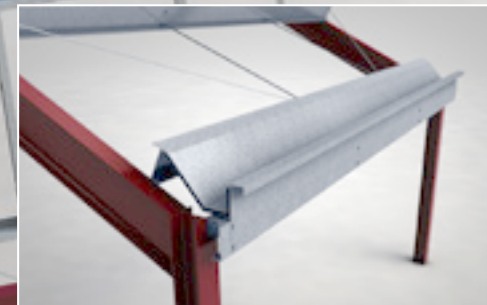

ENCLOSED GUTTER DETAIL 43

Eaves beams are utilised at the junction between the roof and wall cladding panels (traditional internal / external gutters) and are suitable for a wide range of roof slopes and building geometries.



MetPurl eaves beams are available as either a flat back C, or a Sigma profile and both can be fabricated with angled upper flanges to follow the roof slope.

As per purlins and side-rails, eaves beams have their own minimum strutting requirements (see table below). Spans up to 6.2m require a single restraint; for further eaves beam design requirements please refer to the MetPurl software.

- All holes 18mm diameter to suit M16 (grade 8.8) bolts.
- All incoming accessories to be 18mm diameter.
- Underslung eaves strut option available.

Eaves Beams	No. restraints
0.000m to 6.200m	1
6.201m to 9.500m	2
9.501m+	3

DETAILING

Eaves beam connection back to column detail

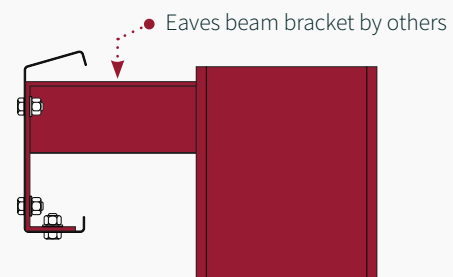

Eaves strut

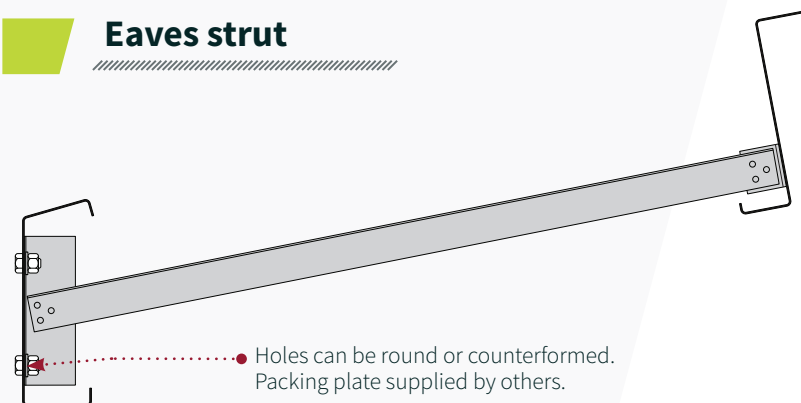

Sigma eaves beam connection back to column detail

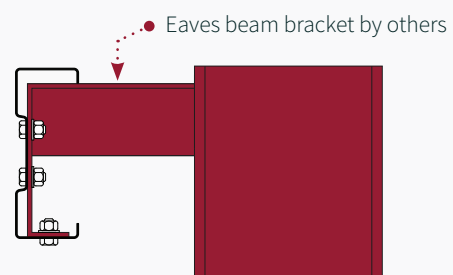

Sigma eaves strut

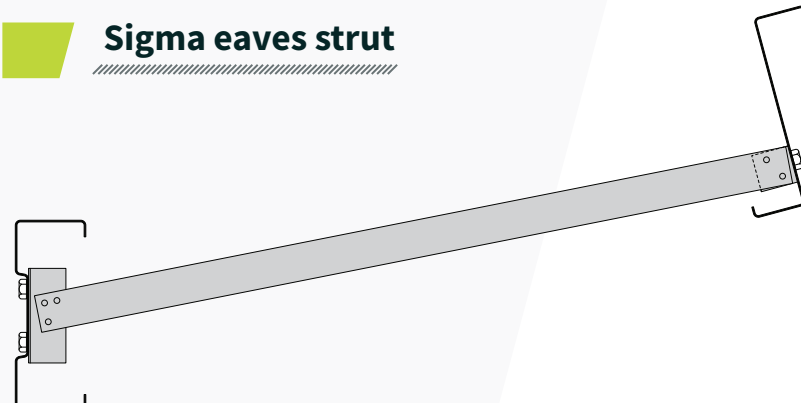

Typical gutter details comprise of either external or internal guttering.

EXTERNAL GUTTER DETAIL

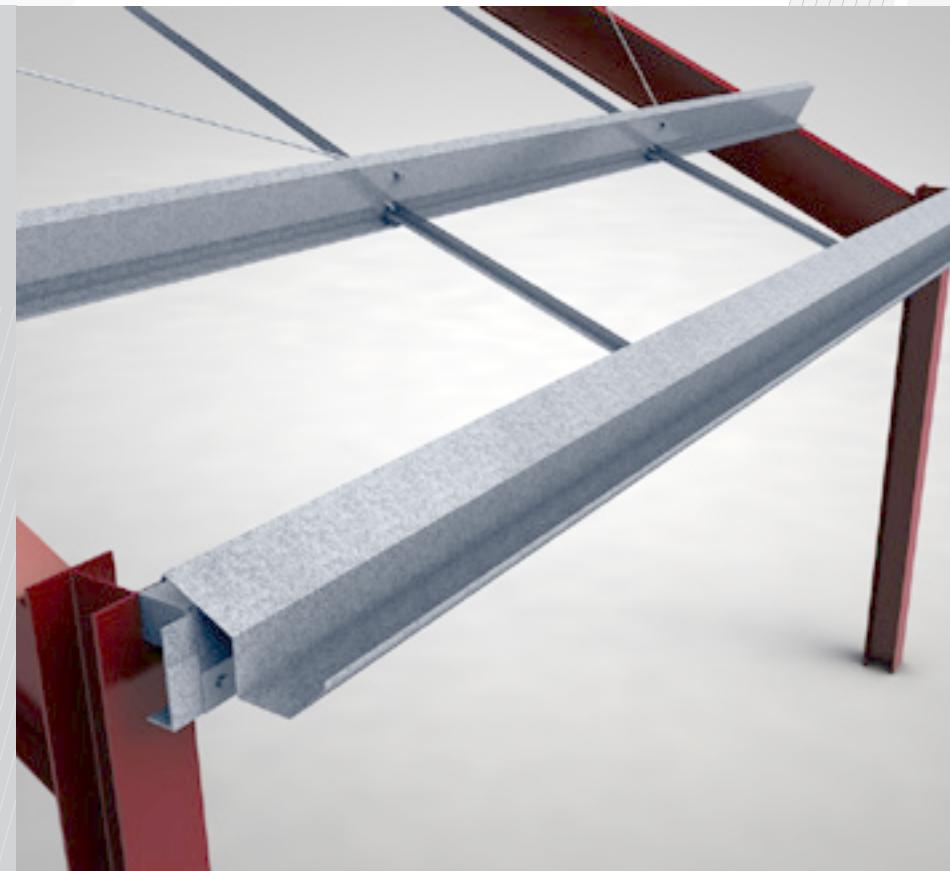

External gutters overhang the external wall line and may be visible from the ground. Typically, these connect back to the upper flange and/or outside web of the eaves beam, which in turn is connected back to the primary columns and strutted back to the first purlin or "eaves purlin". The supporting eaves beam and purlin should be designed as standard.

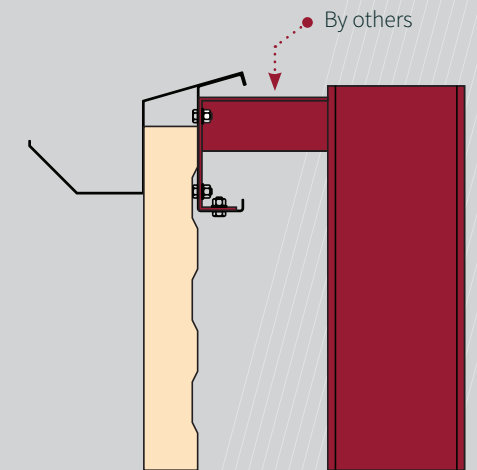

INTERNAL GUTTER DETAIL

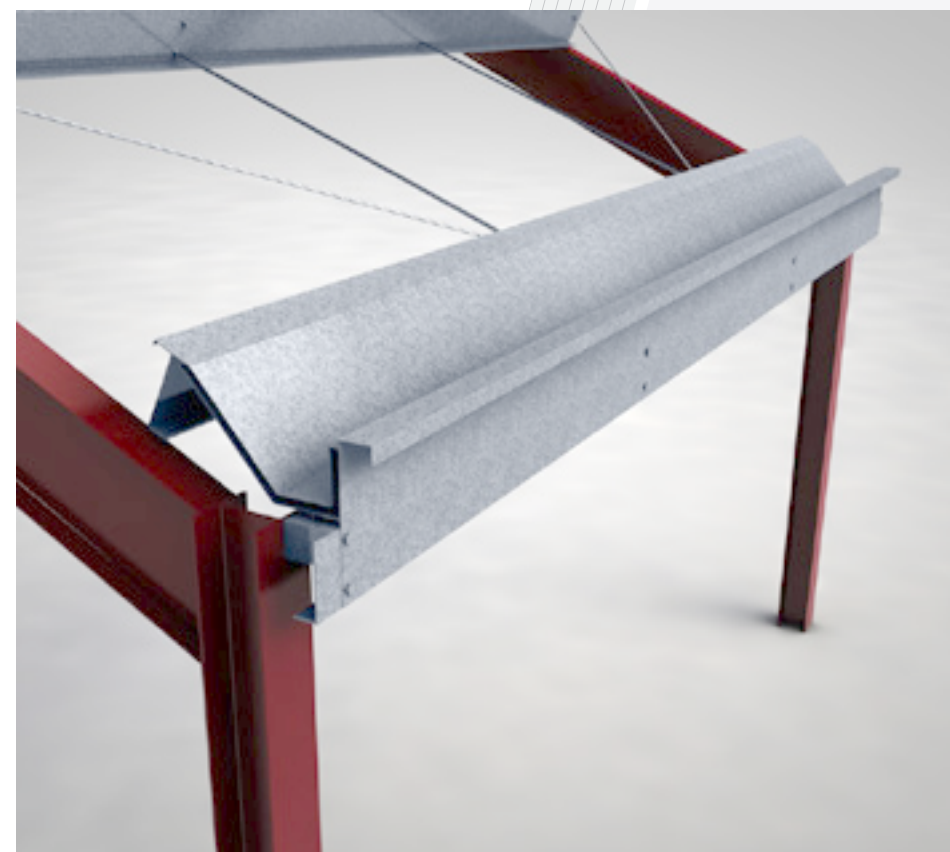

Internal gutters are those which are hidden by the external cladding line. These sit on top of the eaves beam, which is similarly fixed back as above, and may also be fixed back to the top flange of the first purlin.

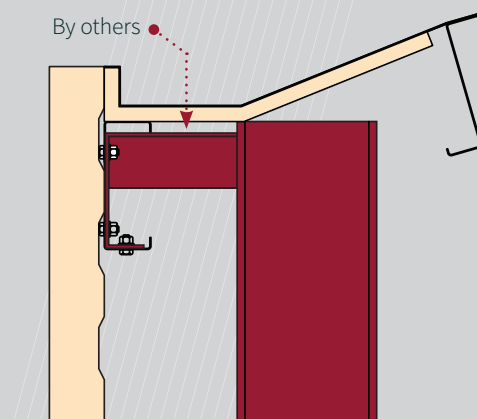



VERTICAL CLADDING LAYOUT 46



SIDE RAIL SUPPORT DETAILS 47



DIAGONAL TIE WIRE DETAILS 47



TYPICAL LAYOUTS 48

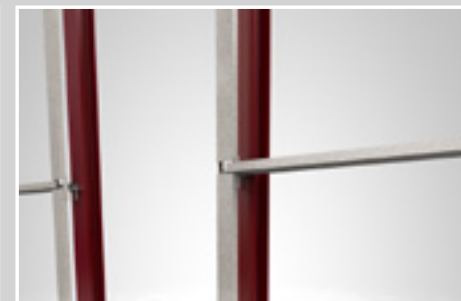

COLUMN JOINT RAIL (CoJR) 49

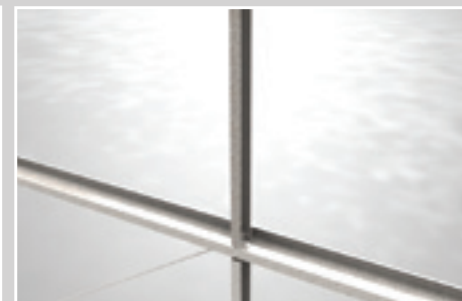

CLADDING SUPPORT RAIL (CSR) 50

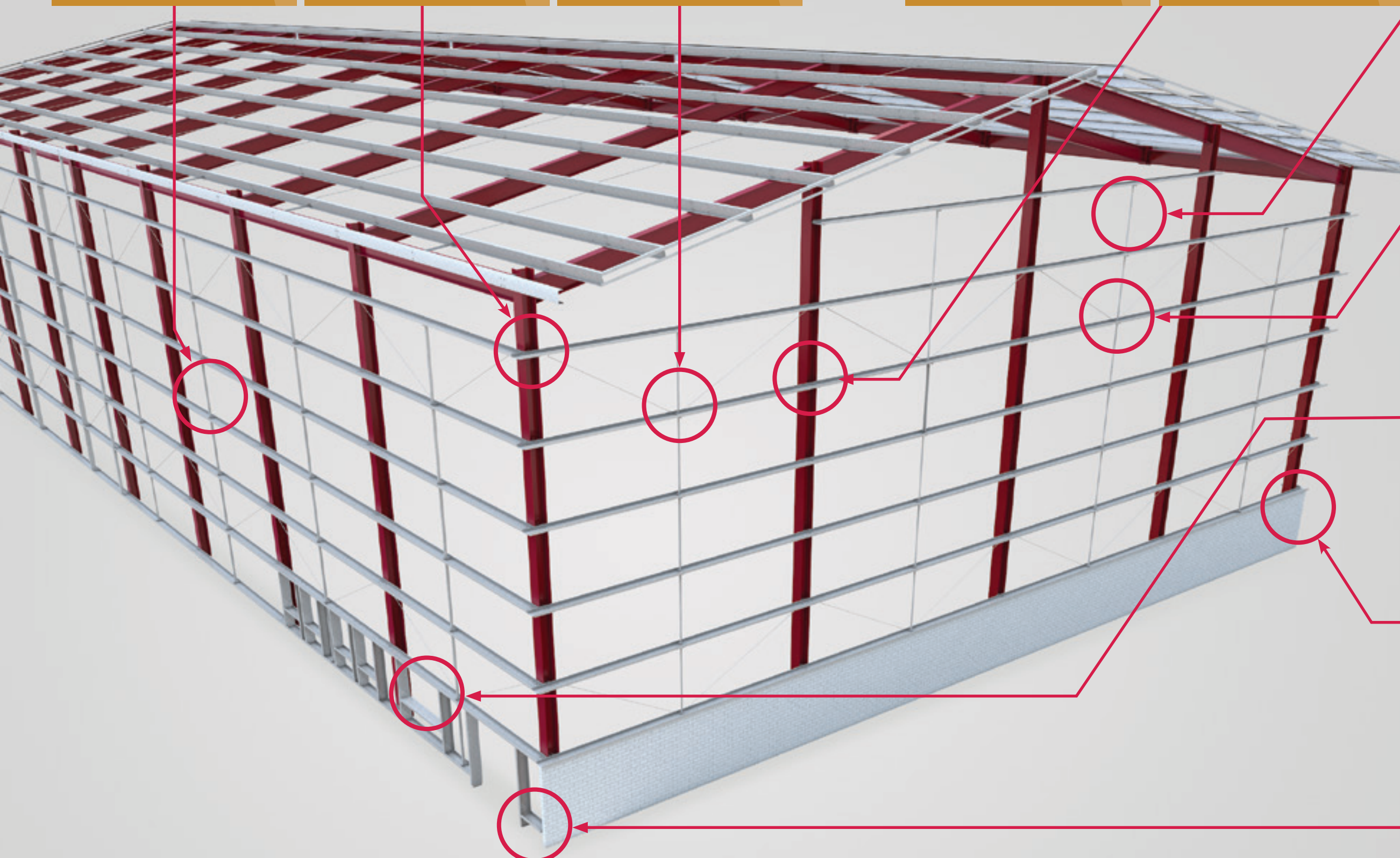

CLADDING JOINT RAIL (CIJR) 51



WINDOW TRIM 52



BRICK CHANNEL 52



DOOR POSTS 52

VERTICAL CLADDING RESTRAINT LAYOUTS

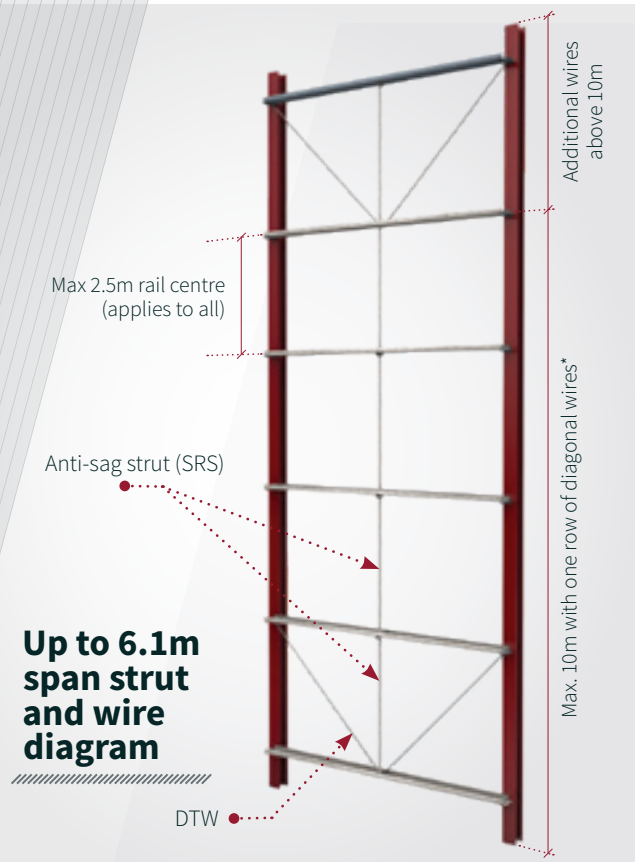

Up to 6.1m span strut and wire diagram

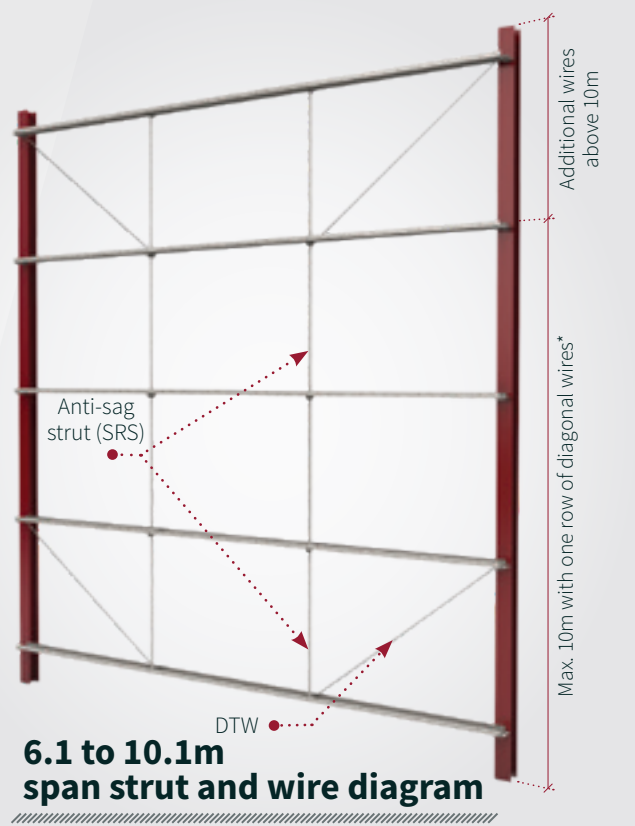

6.1 to 10.1m span strut and wire diagram

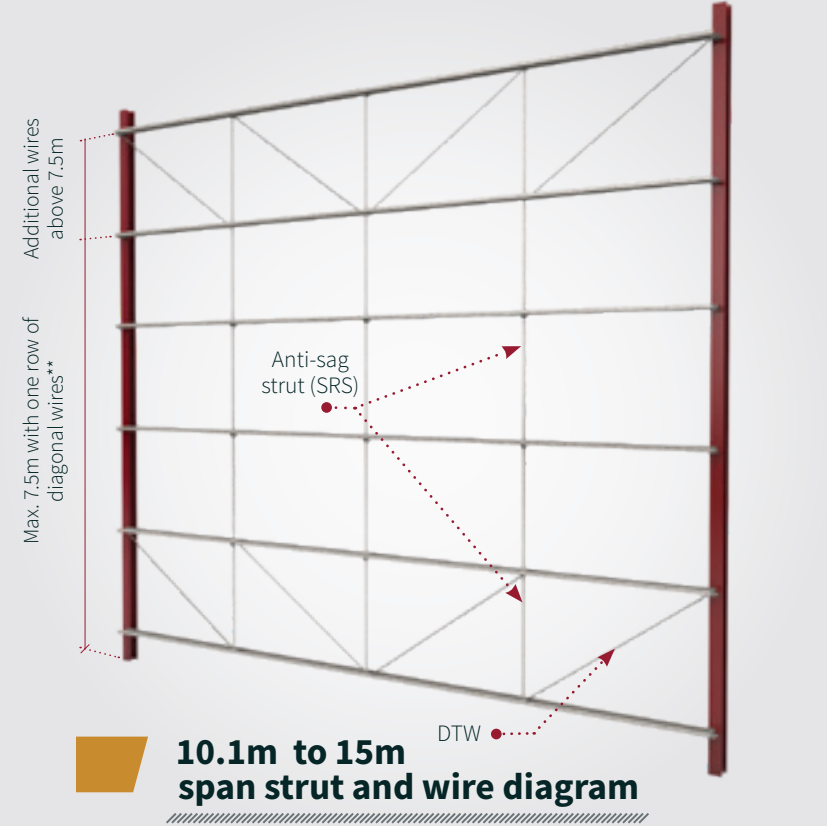

10.1m to 15m span strut and wire diagram

RESTRAINT TABLE

Side Rails	no. restraints
0.000m to 3.200m	0
3.201m to 6.100m	1
6.101m to 10.100m	2
10.101m to 15.000m	3

- Side rail system requires one line of diagonal tie wires (DTWs) per 10m of cladding (in each bay).
- If greater than 10m additional line of diagonal tie wires are required.
- See notes at the bottom of the page.
- Detailer to avoid hybrid systems of single lines of anti-sag struts with multi lines of anti-sag due to the DTW minimum angle, see below.

ALLOWABLE ANGLES

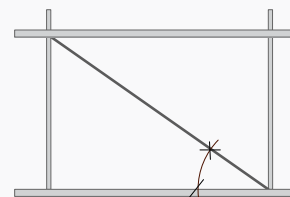

Note: If the angle of the diagonal tie wire (DTW) falls below 25 degrees then an additional anti-sag strut should be introduced.

Min	25°
Max	65°

* Based on a total cladding weight of 0.15 kN/m².

** Based on a total cladding weight of 0.15kN/m². If partial diaphragmatic resistance from the cladding system can be guaranteed, the 7.5m limit can be increased to 10m.

SIDE RAIL SUPPORT (SRS) & DIAGONAL TIE WIRE (DTW) DETAILS

MetPurl Side Rail Supports are made from hot dipped Galvanised S450GD cold rolled material and assembled by way of riveting, offering robust support to the horizontal rails.

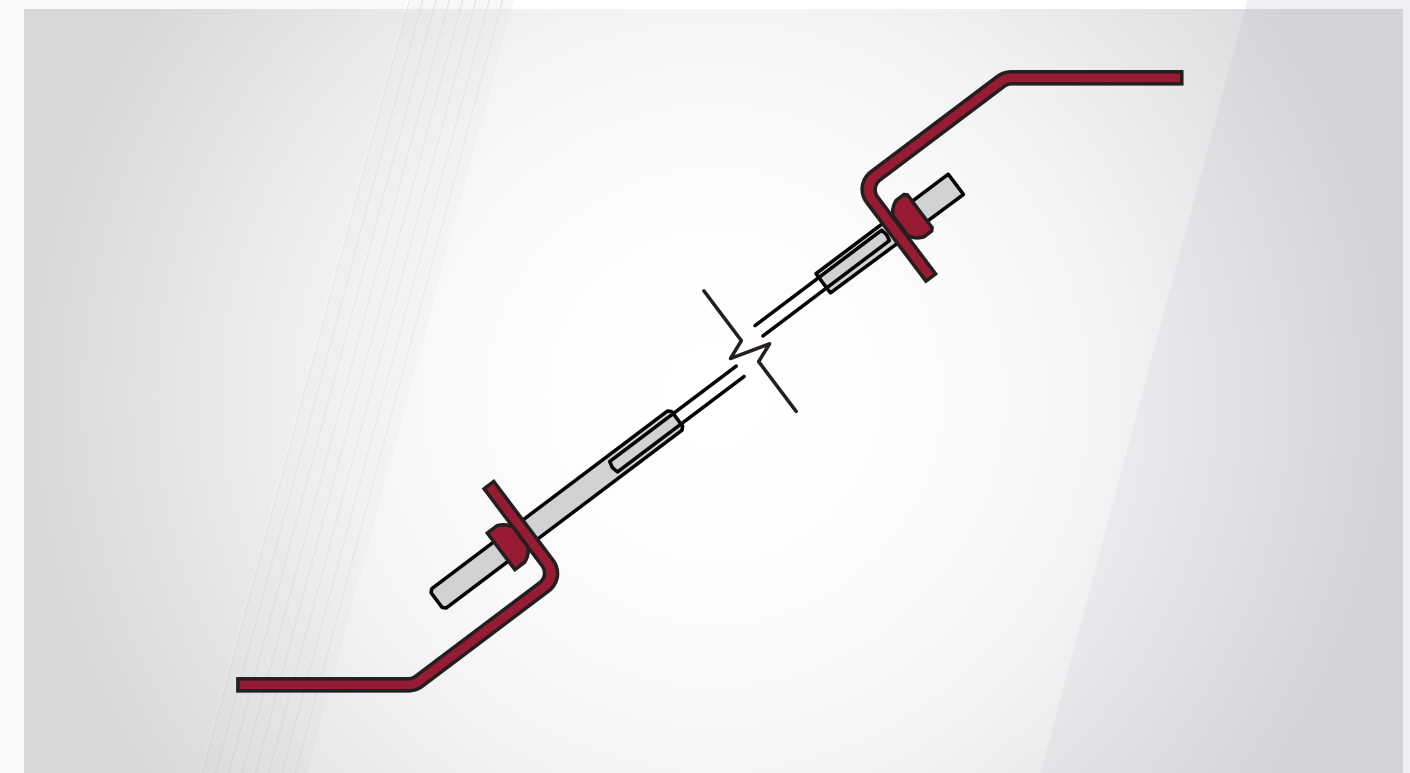
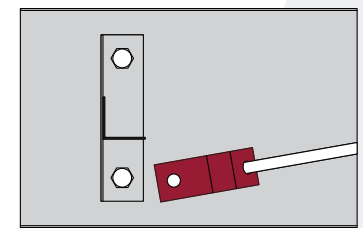
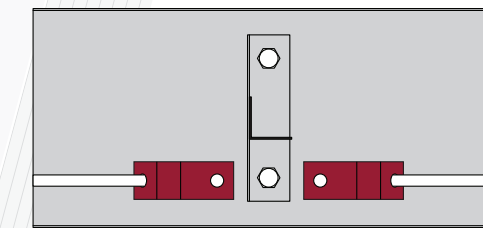
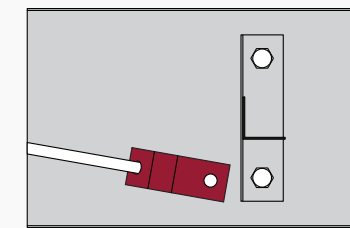
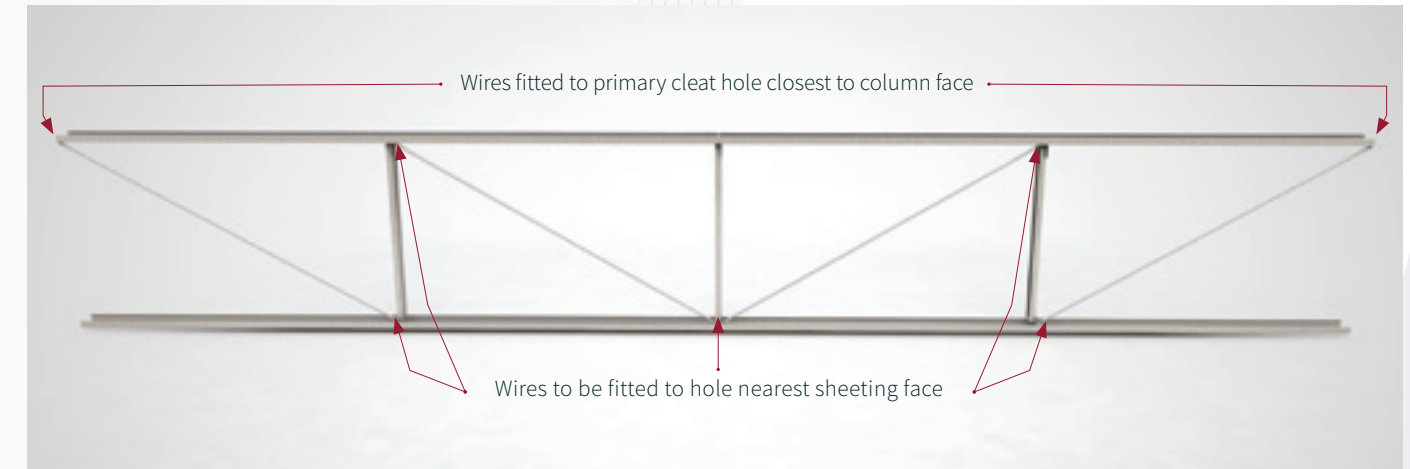

IMPORTANT: Where cladding weights are greater than 0.15kN/m², diagonal tie wire spacing must be reduced pro-rata.

46 Example: Cladding self weight 0.25 kN/m², adopting pro-rata = 0.15 kN/m² / 0.25 kN/m² x 10m = 6m, therefore DTWs system would be required every 6m.

For dimensional information please see Appendix A.

TYPICAL LAYOUTS HORIZONTAL CLADDING



CMF offers three types of Vertical rails for use in conjunction with Horizontal Cladding Panels:

- Column Joint Rail (CoJR)
- Cladding Support Rail (CSR)
- Cladding Joint Rail (CIJR)

Each member is fully factory assembled with cleats riveted both ends as standard for ease of erection on site. Cleats can be supplied loose if require by special instruction.

NOTE:
Wall heights over 10m require an additional row of diagonal wires. See rules / guidance on page 46 for further information regarding prorata of DTW systems and cladding weight.

COLUMN JOINT RAIL (CoJR)

The Column Joint Rail (CoJR) is a 143mm C section turned through 90 degrees and fitted to the outside pairs of holes of the horizontal rails (143 provides the cladding fixing face). This allows the Diagonal Tie Wires (DTW) to pass behind the member and will be fitted to the inside pair of holes.

Should a CoJR be required off the column face this member allows the Diagonal Tie Wires (DTW) to pass behind allowing full structural stability to still be maintained.

The CoJR comes to site fitted with riveted 3mm thick 'U' shaped cleats minimising the amount of loose parts sent to site.

- CMF-COJR16 or COJR20.
- 143mm cladding face
- 58mm depth
- Cleats provided with 18mm dia x 25mm slot holes for fine adjustment on site.

When vertical supports are require to carry horizontal cladding systems the minimum rail depth is 143.

Column Joint Rail (CoJR)		Max Design Loads (kN)	
t (mm)	Joist rail span (side rail CTRS)	Strength (wind; ULS)	Deflection (L/150; SLS)
1.6	1200mm	11.03	13.91
2.0		13.62	17.08
1.6	1600mm	8.27	7.83
2.0		10.21	9.61
1.6	1800mm	7.35	6.18
2.0		9.08	7.59
1.6	2000mm	6.62	5.01
2.0		8.17	6.15
1.6	2400mm	5.52	3.48
2.0		6.81	4.27
1.6	2800mm	4.73	2.56
2.0		5.84	3.14

CoJR struts may be offset from the column only by as far as to the next available cladding support or joint rail.

* Table assumes lateral torsional restraint is provided by the cladding.

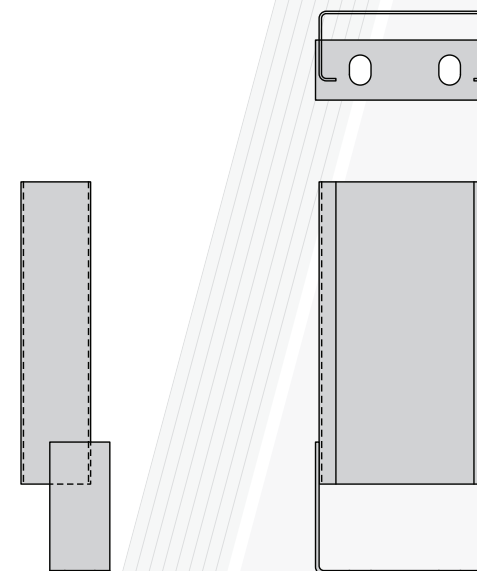

For dimensional information please see Appendix A.



1. Column Joint Rail (CoJR)

2. Cladding Support Rail (CSR)

3. Cladding Joint Rail (CIJR)

IMPORTANT: All elements must be installed to ensure the as built arrangement reflects the design assumptions. For cladding systems with asymmetric panel joints, additional vertical rails and tie wires may be required.

CLADDING SUPPORT RAIL (CSR)

Our Cladding Support Rail (CSR) is used mid cladding panel to support the panel whilst offering structural stability to the horizontal rails.

This vertical member is supplied complete with rivetted cleats. This means fewer loose parts and easier erection on site.

- CMF-CSR16 or CSR20.
- 58mm cladding face
- 143mm depth
- Cleats provided with 18mm dia x 25mm slot holes for fine adjustment on site.

When vertical supports are require to carry horizontal cladding systems the minimum rail depth is 143.

Cladding Support Rail (CSR)		Max Design loads (kN)	
t (mm)	Support rail span (side rail CTRS)	Strength (wind; ULS)	Deflection (L/150; SLS)
1.6	1200mm	40.66	105.80
2.0		55.18	131.29
1.6	1600mm	30.50	59.51
2.0		41.39	73.85
1.6	2000mm	24.40	38.09
2.0		33.11	47.27
1.6	2400mm	20.33	26.45
2.0		27.59	32.82
1.6	2800mm	17.43	19.43
2.0		23.65	24.11
1.6	3200mm	15.25	14.88
2.0		20.69	18.46
1.6	3600mm	13.55	11.76
2.0		18.39	14.59

Table assumes lateral torsional restraint is available from the cladding façade.

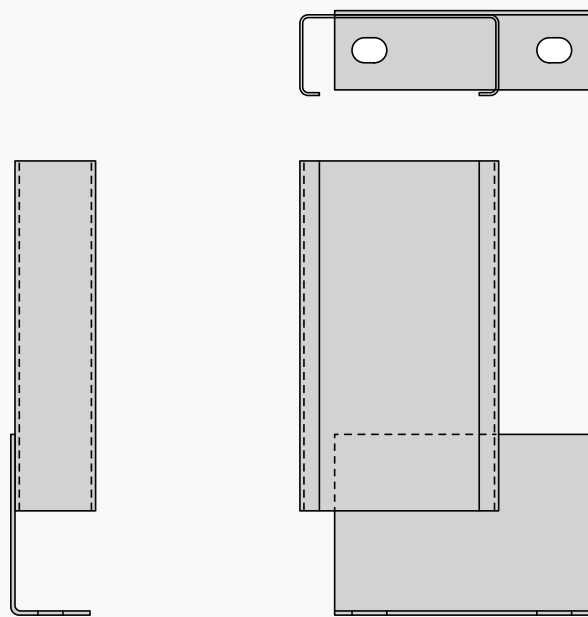

Radius corner version available, seek advice from CMF.

For dimensional information please see Appendix A.



CLADDING JOINT RAIL (CIJR)

The Cladding Joint Rail (CIJR) is an asymmetric C section used to offer support to the cladding panel joints whilst maintaining structural stability to the horizontal rails.

- CMF-CJR16 or CJR20.
- 140mm cladding face
- 115mm depth
- 55mm inner flange
- Cleats provided with 18mm dia x 25mm slot holes for fine adjustment on site.

When vertical supports are require to carry horizontal cladding systems the minimum rail depth is 143.

Column Joint Rail (CIJR)		Max Design Loads (kN)	
t (mm)	Joint Rail Span (side rail CTRS)	Strength (wind; ULS)	Deflection (L/150; SLS)
1.6	1200mm	17.83	52.27
2.0		25.03	64.80
1.6	1600mm	13.37	29.40
2.0		18.77	36.45
1.6	2000mm	10.70	18.82
2.0		15.02	23.33
1.6	2400mm	8.91	13.07
2.0		12.51	16.20
1.6	2800mm	7.64	9.60
2.0		10.73	11.90
1.6	3200mm	6.69	7.35
2.0		9.38	9.11
1.6	3600mm	5.94	5.81
2.0		8.34	7.20

Table assumes lateral torsional restraint is available from the cladding façade.

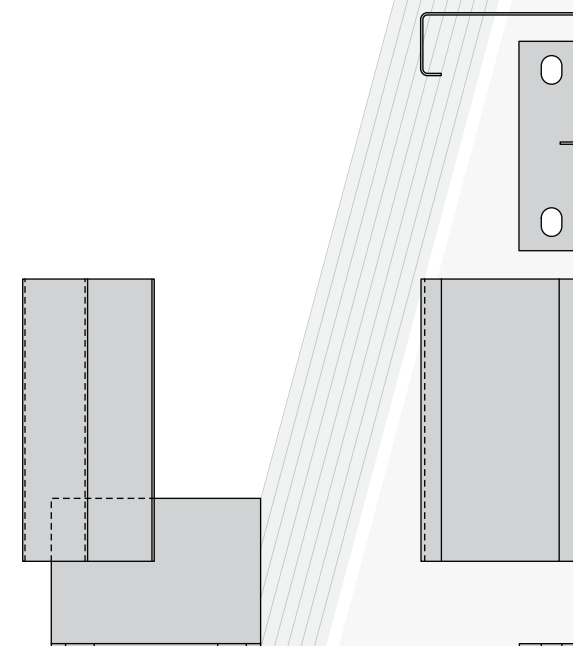

Radius corner version available, seek advice from CMF.

For dimensional information please see Appendix A.



WINDOW TRIMMERS, DOOR POSTS & BRICK CHANNELS

Tekla.
Structures Joints 37 & 101

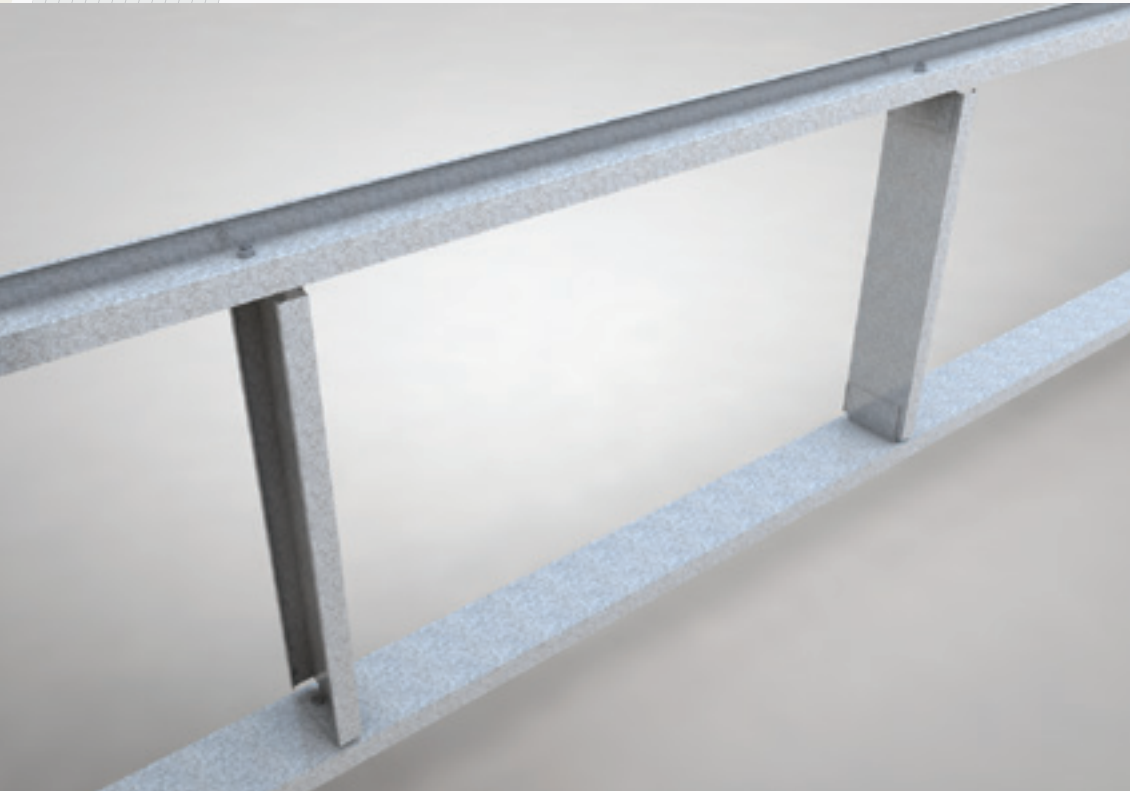

Our Window Trimming vertical rails can be supplied complete with riveted cleats (Tekla Component 101), therefore reducing the number of component parts on site, or loose (Tekla Component 37) with holes both in the section and cleats to bolt together on site.

Typically the window trimmer rail will be supplied in the same width section as the horizontal rail to aid with the internal finishes of the building.



As with the window trimmers the door post can be supplied either with riveted cleats (Tekla Component 101) or loose (Tekla Component 37) dependent on the site application.

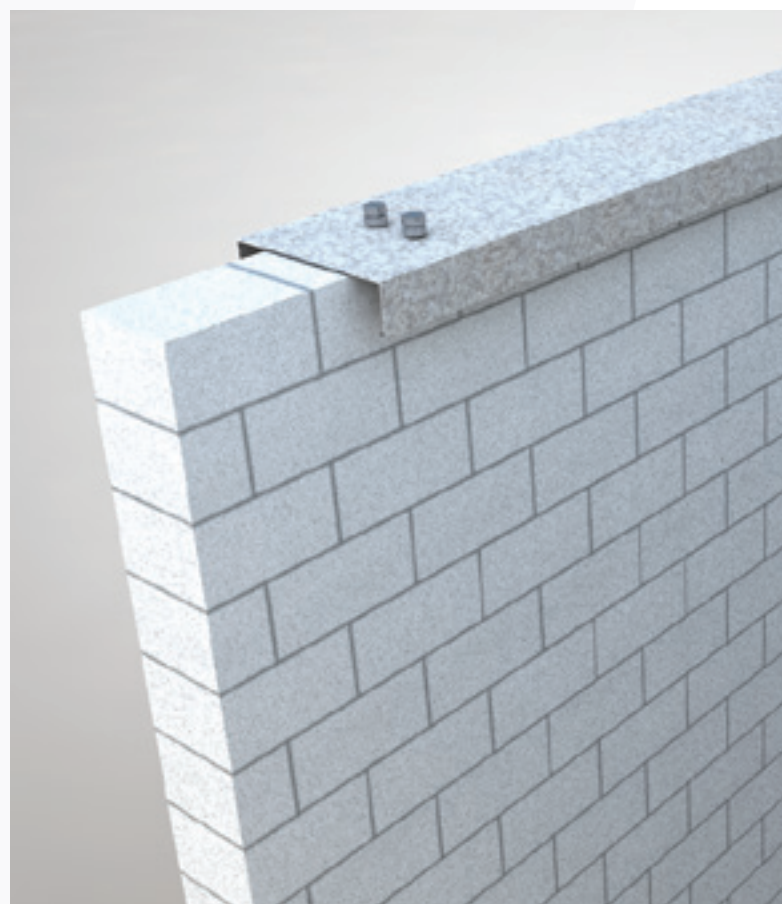

Rails required to offer support to brick or block walls can be designed on the MetPurl Design software.

MetPurl® Design Software

The MetPurl Design Software has been developed in conjunction with the SCI (Steel Construction Institute) and is available to download from our website. Software allow design to British Standard and Eurocode.

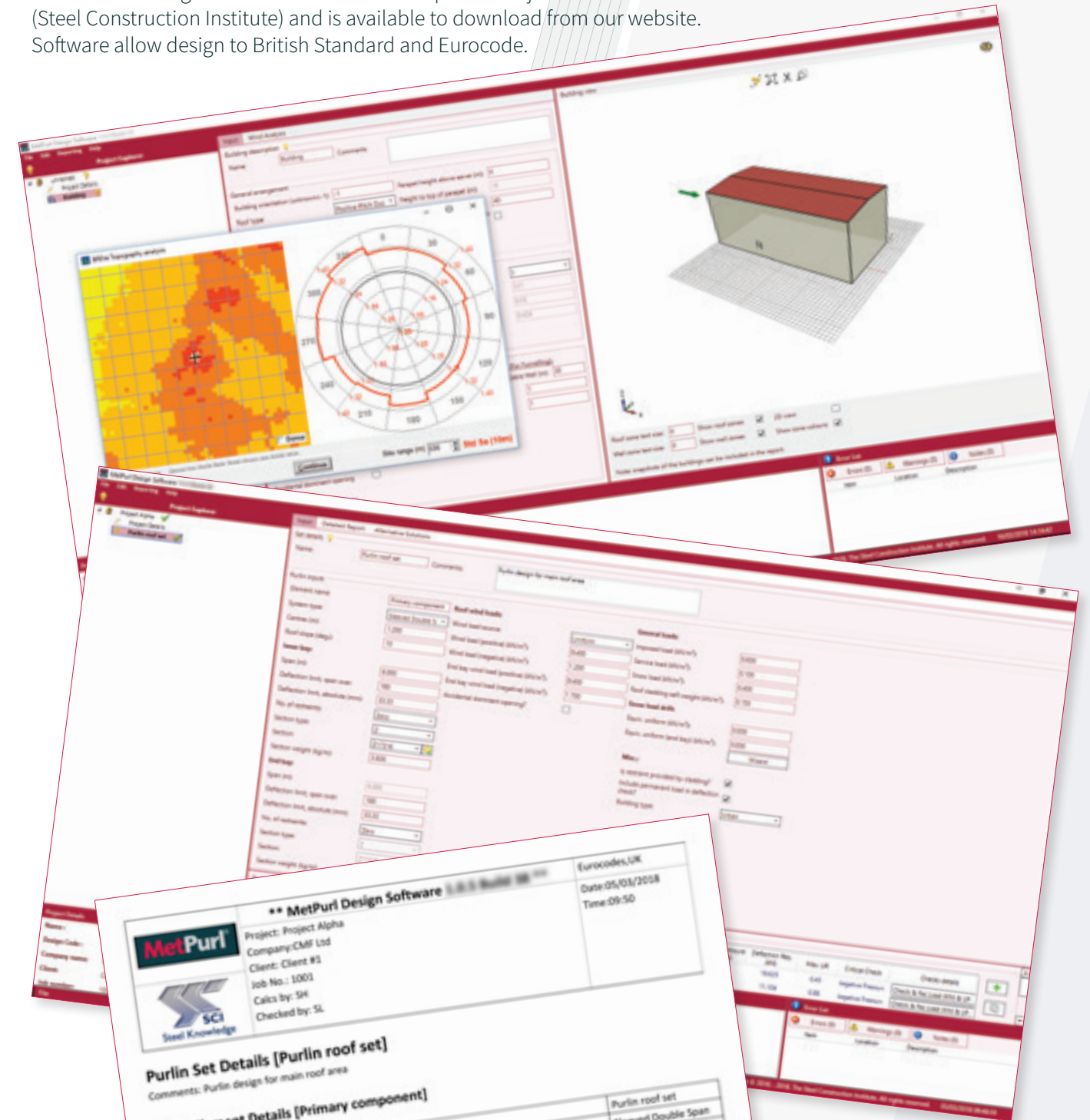

**** MetPurl Design Software 1.0.0.0 Build 00 000** Eurocodes,UK
Date: 05/03/2018
Time: 09:50

Project: Project Alpha
Company: CMF Ltd
Client: Client #3
Job No.: 1001
Calcs by: SH
Checked by: SL

Purlin Set Details [Purlin roof set]
Comments: Purlin design for main roof area

Purlin Element Details [Primary component]		Purlin roof set
Input		Sleaved Double Span
Element name		Z17316
System		6.000
Inner Bay:		180
- Section name/size		Zero
- Span [m]		
- Deflection limit: Span over (mm)		
- No. of restraints (sag bars)		Z17316
End Bay:		6.000
- Section name/size		180
- Span [m]		Zero
- Deflection limit: Span over (mm)		1.200
- No. of restraints (sag bars)		10
		789



METPURL DESIGN SOFTWARE

Available to download from the CMF website.

VISIT WEBSITE

www.cmf.uk.com

LOAD SPAN TABLES



Within the following pages load span tables are provided for the various system layouts and section geometries. Supplying maximum design loads for both serviceability and strength conditions, the capacities given enable designs utilising various criteria and restraint conditions – including two deflection limit options and three member-restraint options.

The values displayed have been produced through numerical calculations in accordance with BS EN 1993-1-3 and may be read in parallel with the MetPurl design software where both have been completed with ratification and assessment by the Steel Construction Institute (SCI).

For designs that fall outside of the remit of these tables, and for more detailed design functionality, the MetPurl software is freely available. For further information on these tables and the MetPurl product range, please contact CMF Ltd.



Case Study

PROJECT

Michelin, Stoke-on-Trent x 2 units.

TONNAGE

Unit 1 - 85 tonnes total incl. accessories
Unit 2 - 88 tonnes total incl. accessories

Z-SECTIONS	56
Single Span Butted	56
Double Span Butted	58
Single/Double Span Sleeved	60
Heavy End Bay Single/Double Span – End Bay	62
Heavy End Bay Single Span – Inner Bay	64
Heavy End Bay Double Span – Inner Bay	66
C-SECTIONS	68
Single Span Butted	68
Double Span Butted	70
Side Rail System – Single/Double Span Sleeved	72
Side Rail System – Heavy End Bay Single Span	74

Z-SECTION PURLIN SYSTEM

SINGLE SPAN BUTTED

Section Reference	Weight (kg/m)	Span (m)	Design load in kN per span SLS deflection, ULS strength					
			Deflection check		Down load	Uplift load		
			L/180	L/360		0 sag	1 sag	2 sag
Z12315	2.81	4.00	4.79	2.39	14.55	9.93	14.55	14.55
Z12316	3.00		5.10	2.55	16.05	10.96	16.05	16.05
Z14313	2.79	4.00	6.47	3.23	12.97	10.16	12.97	12.97
Z14314	3.00		6.96	3.48	15.06	11.61	15.06	15.06
Z14315	3.22	4.00	7.45	3.72	17.25	13.12	17.25	17.25
Z17313	3.18		10.58	5.29	15.01	12.40	15.01	15.01
Z12315	2.81	4.50	3.78	1.89	12.93	8.16	12.13	12.93
Z12316	3.00		4.03	2.01	14.27	9.02	13.37	14.27
Z14313	2.79	4.50	5.11	2.56	11.53	8.22	11.53	11.53
Z14314	3.00		5.50	2.75	13.39	9.42	13.39	13.39
Z14315	3.22	4.50	5.89	2.94	15.33	10.66	15.33	15.33
Z14316	3.44		6.27	3.13	17.36	11.96	17.36	17.36
Z17313	3.18	4.50	8.35	4.18	13.35	10.02	13.35	13.35
Z17314	3.43		9.00	4.50	15.63	11.54	15.63	15.63
Z20313	3.48	5.00	12.13	6.07	14.60	10.71	14.33	14.43
Z20314	3.15		13.06	6.53	17.24	12.41	17.02	17.22
Z20315	4.02	5.00	13.99	6.99	20.04	14.20	19.85	20.04
Z14313	2.79		5.00	4.14	2.07	10.38	6.81	10.04
Z14314	3.00	4.45		2.23	12.05	7.83	11.61	12.05
Z14315	3.22	5.00	4.77	2.38	13.80	8.89	13.22	13.80
Z14316	3.44		5.08	2.54	15.62	9.99	14.88	15.62
Z17313	3.18	5.00	6.77	3.38	12.01	8.25	11.75	12.01
Z17314	3.43		7.29	3.64	14.07	9.53	13.76	14.07
Z17315	3.68	5.00	7.80	3.90	16.23	10.86	15.86	16.23
Z17316	3.93		8.31	4.16	18.50	12.24	18.03	18.50
Z20313	3.48	5.00	9.83	4.91	13.14	8.78	12.42	12.74
Z20314	3.15		10.08	5.29	15.52	10.20	14.71	15.19
Z20315	4.02	5.00	11.33	5.67	18.03	11.69	17.10	17.79
Z23314	4.07		14.65	7.32	17.27	10.92	15.77	16.35
Z12316	3.00	5.50	2.70	1.35	11.67	6.84	9.50	11.03
Z14315	3.22		3.94	1.97	12.54	7.57	11.35	12.44
Z14316	3.44	5.50	4.20	2.10	14.21	8.53	12.75	14.09
Z14318	3.87		4.70	2.35	17.39	10.44	15.44	17.25
Z14320	4.29	5.50	5.21	2.60	20.34	12.30	18.01	20.22
Z17314	3.43		6.02	3.01	12.79	8.02	11.96	12.64
Z17315	3.68	5.50	6.45	3.22	14.55	9.16	13.74	14.64
Z17316	3.93		6.87	3.44	16.81	10.36	15.57	16.73
Z17318	4.42	5.50	7.71	3.86	21.18	12.91	19.38	21.13
Z20313	3.48		8.12	4.06	11.95	7.34	10.83	11.35
Z20314	3.15	5.50	8.74	4.37	14.10	8.55	12.78	13.52
Z20315	4.02		9.36	4.68	16.39	9.83	14.81	15.81
Z20316	4.29	5.50	9.98	4.99	18.79	11.17	16.91	18.20
Z23314	4.07		12.10	6.05	15.70	9.11	13.69	14.54
Z23315	4.37	5.50	12.96	6.48	17.69	10.32	15.57	16.60
Z23316	4.66		13.82	6.91	20.42	11.79	17.92	19.28
Z17315	3.68	6.00	5.42	2.71	13.53	7.88	11.95	13.09
Z17316	3.93		5.77	2.89	15.41	8.93	13.51	14.94
Z17318	4.42	6.00	6.48	3.24	19.42	11.18	16.10	18.81
Z20314	3.15		7.35	3.67	12.93	7.29	11.14	12.11
Z20315	4.02	6.00	7.87	3.93	15.03	8.41	12.87	14.14
Z20316	4.29		8.39	4.19	17.22	9.81	14.62	16.25
Z20318	4.83	6.00	9.42	4.71	21.89	12.11	18.36	20.70
Z20320	5.37		10.43	5.22	26.89	14.84	22.20	25.39
Z23314	4.07	6.00	10.17	5.09	14.39	7.73	11.93	13.02
Z23315	4.37		10.89	5.45	16.22	8.79	13.54	14.85
Z23316	4.66	6.00	11.61	5.81	18.72	10.08	15.54	17.22
Z23318	5.25		13.04	6.52	24.04	12.85	19.69	22.23

Section Reference	Weight (kg/m)	Span (m)	Design load in kN per span SLS deflection, ULS strength					
			Deflection check		Down load	Uplift load		
			L/180	L/360		0 sag	1 sag	2 sag
Z17320	4.91	6.50	6.12	3.05	21.87	12.00	17.46	20.39
Z17323	5.64		6.99	3.50	26.82	14.97	21.37	25.03
Z20315	4.02	6.50	6.70	3.35	13.87	7.31	11.23	12.70
Z20316	4.29		7.15	3.57	15.90	8.36	12.64	14.57
Z20318	4.83	6.50	8.02	4.01	20.21	10.62	15.92	18.50
Z20320	5.37		8.89	4.45	24.82	13.06	19.23	22.62
Z20323	6.17	6.50	10.18	5.09	31.96	16.94	24.29	28.89
Z23314	4.07		8.67	4.33	13.29	6.66	10.41	11.71
Z23315	4.37	6.50	9.28	4.64	14.97	7.60	11.81	13.35
Z23316	4.66		9.90	4.95	17.28	8.75	13.52	15.45
Z23318	5.25	6.50	11.11	5.56	22.19	11.23	17.06	19.88
Z26316	5.03		13.21	6.61	18.89	9.14	14.30	16.42
Z26318	5.66	6.50	14.84	7.42	23.85	11.66	17.96	20.93
Z17318	4.42		4.76	2.38	16.64	8.76	12.73	15.08
Z17320	4.91	7.00	5.27	2.64	20.31	10.73	15.27	18.23
Z20316	4.29		6.16	3.08	14.76	7.39	11.15	13.11
Z20318	4.83	7.00	6.92	3.46	18.77	9.43	13.89	16.66
Z20320	5.37		7.67	3.83	23.04	11.65	16.77	20.21
Z23315	4.37	7.00	8.00	4.00	13.90	6.67	10.33	12.05
Z23316	4.66		8.53	4.27	16.04	7.70	11.80	13.91
Z23318	5.25	7.00	9.24	4.79	20.60	9.94	14.86	17.82
Z23320	5.83		10.62	5.31	25.49	12.39	18.07	21.92
Z26316	5.03	7.00	12.17	6.08	33.08	16.31	23.02	28.15
Z26318	5.66		11.39	5.70	17.54	8.02	12.46	14.78
Z26320	6.29	7.00	12.80	6.40	22.15	10.29	15.62	18.78
Z30318	6.71		14.19	7.10	27.63	12.94	19.15	23.34
Z20318	4.83	7.50	20.46	10.23	27.07	14.71	22.62	24.56
Z20320	5.37		6.03	3.01	17.52	8.48	12.20	14.90
Z23316	4.66	7.50	6.68	3.34	21.51	10.51	14.73	18.09
Z23318	5.25		7.43	3.72	14.97	6.86	10.35	12.56
Z23320	5.83	7.50	8.35	4.17	19.23	8.91	13.02	16.02
Z23323	6.70		9.25	4.63	23.79	11.15	15.83	19.62
Z23325	7.28	7.50	10.60	5.30	30.82	14.74	20.21	25.10
Z26316	5.03		11.48	5.74	35.22	17.07	23.04	28.52
Z26318	5.66	7.50	9.92	4.96	16.37	7.11	10.90	13.33
Z26320	6.29		11.15	5.57	20.67	9.19	13.66	16.89
Z30318	6.71	7.50	12.36	6.18	25.79	11.61	16.74	20.90
Z30320	7.46		14.16	7.08	33.77	15.53	21.55	27.01
Z35318	8.23	7.50	17.83	8.91	25.26	12.93	20.16	22.45
Z35320	9.15		19.78	9.89	30.66	15.86	24.60	27.69
Z20318	4.83	8.00	30.72	15.36	31.56	21.84	28.99	29.33
Z20320	5.37		5.30	2.65	16.42	7.69	10.79	13.41
Z20323	6.17	8.00	5.87	2.93	20.17	9.56	13.04	16.23
Z23318	5.25		6.72	3.36	25.96	12.55	16.56	20.50
Z23320	5.83	8.00	7.34	3.67	18.03	8.06	11.48	14.41
Z23323	6.70		8.13	4.07	22.31	10.12	13.98	17.60
Z23325	7.28	8.00	9.31	4.66	28.95	13.44	17.89	22.42
Z26316	5.03		10.09	5.05	33.02	15.59	20.43	25.45
Z26318	5.66	8.00	8.72	4.36	15.35	6.38	9.17	12.05
Z26320	6.29		9.80	4.90	19.38	8.28	12.02	15.21
Z30320	7.46	8.00	10.86	5.43	24.18	10.52	14.74	18.00
Z30323	8.31		12.45	6.22	31.66	14.14	19.03	24.13
Z30330	11.18	8.00	15.67	7.83	23.68	11.49	18.01	20.57
Z30330	11.18		17.39	8.69	28.74	14.16	21.93	25.31
Z30325	9.15	8.00	6.45	3.22	27.16	13.11	16.66	20.49
Z30327	7.23		6.94	3.47	29.77	14.64	18.47	22.55
Z33318	5.25	8.00	6.50	3.25	16.97	7.35	10.19	13.00
Z33320	5.83		7.20	3.60	20.99	9.27	12.43	15.81
Z33323	6.70	8.00	8.25	4.13	27.24	12.35	15.96	20.08
Z33325	7.28		8.94	4.47	31.08	14.35	18.26	22.77
Z26318	5.66	8.50	8.68	4.34	18.24	7.54	10.63	13.72
Z26320	6.29		9.62	4.81	22.72	9.61	13.07	16.84
Z26323	7.23	8.50	11.03	5.51	29.79	12.97	16.93	21.59
Z30318	6.71		13.88	6.94	22.29	10.30	16.11	18.90
Z30320	7.46	8.50	15.40	7.70	27.05	12.75	19.60	23.21
Z35318	8.23		23.92	11.91	27.87	17.10	24.41	25.28
Z35320	9.15	8.50	26.56	13.28	33.67	20.77	30.15	31.36

Section Reference	Weight (kg/m)	Span (m)	Design load in kN per span SLS deflection, ULS strength					
			Deflection check		Down load	Uplift load		
			L/180	L/360		0 sag	1 sag	2 sag
Z20323	6.17	9.00	5.31	2.65	23.08	10.69	13.35	16.52
Z20325	6.70		5.75	2.87	25.65	12.15	15.04	18.42
Z20327	7.23	9.00	6.19	3.09	28.11	13.58	16.70	20.29
Z23320	5.83		6.43	3.21	19.83	8.54	11.13	14.23
Z23323	6.70	9.00	7.36	3.68	25.73	11.42	14.35	18.02
Z23325	7.28		7.97	3.99	29.35	13.29	16.45	20.43
Z23327	7.86	9.00	8.29	4.29	32.96	15.20	18.52	22.83
Z26318	5.66		7.74	3.87	17.23	6.91	9.46	12.38
Z26320	6.29	9						

Z-SECTION PURLIN SYSTEM

DOUBLE SPAN BUTTED

Section Reference	Weight (kg/m)	Span (m)	Design load in kN per span SLS deflection, ULS strength					
			Deflection check		Down load	Uplift load		
			L/180	L/360		0 sag	1 sag	2 sag
Z12315	2.81	4.00	9.54	4.77	19.90	19.90	19.90	19.90
Z12316	3.00		10.15	5.08	21.97	21.97	21.97	21.97
Z14313	2.79		12.88	6.44	17.65	17.65	17.65	17.65
Z14314	3.00	4.50	13.86	6.93	20.52	20.52	20.52	20.52
Z14315	3.22		14.84	7.42	23.53	23.53	23.53	23.53
Z17313	3.18		21.07	10.54	20.32	20.32	20.32	20.32
Z12315	2.81	5.00	7.53	3.77	17.69	17.48	17.69	17.69
Z12316	3.00		8.02	4.01	19.53	19.23	19.53	19.53
Z14313	2.79		10.18	5.09	15.69	15.69	15.69	15.69
Z14314	3.00	5.50	10.95	5.48	18.24	18.24	18.24	18.24
Z14315	3.22		11.72	5.86	20.92	20.92	20.92	20.92
Z14316	3.44		12.49	6.24	23.72	23.72	23.72	23.72
Z17313	3.18	6.00	16.65	8.32	18.07	18.07	18.07	18.07
Z17314	3.43		17.92	8.96	21.20	21.20	21.20	21.20
Z20313	3.48		24.17	12.08	19.64	19.64	19.64	19.64
Z20314	3.15	6.50	26.02	13.01	23.27	23.27	23.27	23.27
Z20315	4.02		27.87	13.93	27.11	27.11	27.11	27.11
Z14313	2.79		8.25	4.12	14.12	14.12	14.12	14.12
Z14314	3.00	7.00	8.87	4.44	16.42	16.42	16.42	16.42
Z14315	3.22		9.50	4.75	18.83	18.83	18.83	18.83
Z14316	3.44		10.12	5.00	21.34	21.34	21.34	21.34
Z17313	3.18	7.50	13.49	6.74	16.28	16.28	16.28	16.28
Z17314	3.43		14.52	7.23	19.08	19.08	19.08	19.08
Z17315	3.68		15.54	7.77	22.06	22.06	22.06	22.06
Z17316	3.93	8.00	16.56	8.28	25.18	25.18	25.18	25.18
Z20313	3.48		19.53	9.79	17.68	17.68	17.68	17.68
Z20314	3.15		21.08	10.54	20.94	20.94	20.94	20.94
Z20315	4.02	8.50	22.57	11.29	24.40	24.40	24.40	24.40
Z23314	4.07		29.17	14.67	22.94	22.94	22.94	22.94
Z12316	3.00		9.00	5.37	2.69	15.98	13.67	15.98
Z14315	3.22	7.85		3.92	17.12	16.31	17.12	17.12
Z14316	3.44	8.36		4.18	19.40	18.26	19.40	19.40
Z14318	3.87	9.50	9.37	4.69	23.79	22.10	23.79	23.79
Z14320	4.29		10.31	5.18	27.87	25.80	27.87	27.87
Z17314	3.43		12.00	6.00	17.35	17.35	17.35	17.35
Z17315	3.68	10.00	12.84	6.42	20.05	20.05	20.05	20.05
Z17316	3.93		13.69	6.84	22.89	22.66	22.89	22.89
Z17318	4.42		15.36	7.68	28.90	27.90	28.90	28.90
Z20313	3.48	10.50	16.18	8.09	16.07	16.07	16.07	16.07
Z20314	3.15		17.42	8.71	19.04	19.04	19.04	19.04
Z20315	4.02		18.65	9.33	22.18	21.90	22.18	22.18
Z20316	4.29	11.00	19.88	9.94	25.47	24.72	25.47	25.47
Z23314	4.07		24.11	12.06	20.86	20.64	20.86	20.86
Z23315	4.37		25.82	12.91	23.81	23.24	23.81	23.81
Z23316	4.66	11.50	27.53	13.77	27.56	26.41	27.56	27.56
Z17315	3.68		10.79	5.40	18.38	17.23	18.38	18.38
Z17316	3.93		11.50	5.08	20.98	19.39	20.98	20.98
Z17318	4.42	12.00	12.91	6.45	26.49	23.93	26.49	26.49
Z20314	3.15		14.64	7.32	17.45	16.29	17.45	17.45
Z20315	4.02		15.67	7.84	20.33	18.64	20.33	20.33
Z20316	4.29	12.50	16.71	8.35	23.35	21.08	23.35	23.35
Z20318	4.83		18.73	9.38	29.76	26.22	29.76	29.76
Z20320	5.37		20.79	10.39	36.65	31.67	36.65	36.65
Z23314	4.07	13.00	20.26	10.13	19.12	17.53	19.12	19.12
Z23315	4.37		21.70	10.85	21.83	19.47	21.83	21.83
Z23316	4.66		23.13	11.57	25.26	22.42	25.26	25.26
Z23318	5.25	13.50	25.98	12.99	32.57	28.17	32.57	32.57

Section Reference	Weight (kg/m)	Span (m)	Design load in kN per span SLS deflection, ULS strength					
			Deflection check		Down load	Uplift load		
			L/180	L/360		0 sag	1 sag	2 sag
Z17320	4.91	6.50	12.18	6.09	29.89	25.07	29.89	29.89
Z17323	5.64		13.93	6.97	36.72	30.87	36.72	36.72
Z20315	4.02		13.36	6.68	18.77	16.08	18.77	18.77
Z20316	4.29	7.00	14.24	7.12	21.56	18.21	21.56	21.56
Z20318	4.83		15.98	7.99	27.49	22.73	27.49	27.49
Z20320	5.37		17.71	8.86	33.83	27.55	33.65	33.83
Z20323	6.17	7.50	20.27	10.14	43.66	35.11	42.51	43.66
Z23314	4.07		17.26	8.63	17.65	15.05	17.65	17.65
Z23315	4.37		18.49	9.24	20.15	16.99	20.15	20.15
Z23316	4.66	8.00	19.71	9.85	23.32	19.34	23.32	23.32
Z23318	5.25		22.14	11.07	30.07	24.34	29.86	30.07
Z26316	5.03		26.32	13.16	25.18	20.51	25.02	25.18
Z26318	5.66	8.50	29.56	14.78	32.19	25.64	31.43	32.19
Z17318	4.42		9.48	4.74	22.71	18.32	22.28	22.71
Z17320	4.91		10.50	5.25	27.00	22.15	26.71	27.00
Z20316	4.29	9.00	12.27	6.14	20.02	15.93	19.51	20.02
Z20318	4.83		13.78	6.89	25.52	19.96	24.32	25.52
Z20320	5.37		15.27	7.63	31.41	24.28	29.34	31.41
Z23315	4.37	9.50	15.94	7.97	18.71	14.77	18.09	18.71
Z23316	4.66		17.00	8.50	21.65	16.86	20.65	21.65
Z23318	5.25		19.09	9.54	27.92	21.31	26.01	27.92
Z23320	5.83	10.00	21.16	10.09	34.65	26.10	31.62	34.65
Z26316	5.03		24.23	12.12	45.10	33.67	40.28	45.10
Z26318	5.66		22.69	11.35	23.38	17.82	21.81	23.38
Z26320	6.29	10.50	25.49	12.75	29.89	22.37	27.34	29.89
Z30318	6.71		28.27	14.13	37.43	27.60	33.51	37.43
Z20318	4.83		12.00	6.00	23.82	17.72	21.35	23.82
Z20320	5.37	11.00	13.30	6.65	29.32	21.64	25.78	29.32
Z23316	4.66		14.81	7.40	20.21	14.86	18.11	20.21
Z23318	5.25		16.63	8.31	26.06	18.86	22.78	26.06
Z23320	5.83	11.50	18.43	9.22	32.34	23.20	27.71	32.34
Z23323	6.70		21.11	10.56	42.09	30.06	35.37	42.09
Z23325	7.28		22.87	11.44	48.09	34.52	40.31	48.09
Z26316	5.03	12.00	19.77	9.88	21.82	15.65	19.08	21.82
Z26318	5.66		22.21	11.10	27.90	19.74	23.91	27.90
Z26320	6.29		24.62	12.31	34.94	24.46	29.30	34.94
Z26323	7.23	12.50	28.21	14.11	45.91	31.99	37.72	45.91
Z30318	6.71		35.51	17.54	33.52	29.28	33.52	33.52
Z30320	7.46		39.41	19.70	41.32	35.38	41.32	41.32
Z35318	8.23	13.00	61.19	30.60	40.43	40.43	40.43	40.43
Z20318	4.83		10.55	5.25	22.33	15.90	18.87	22.33
Z20320	5.37		11.69	5.85	27.49	19.47	22.82	27.49
Z20323	6.17	13.50	13.38	6.69	35.48	25.13	28.97	35.48
Z23318	5.25		14.61	7.31	24.43	16.87	20.09	24.43
Z23320	5.83		16.20	8.10	30.32	20.82	24.46	30.32
Z23323	6.70	14.00	18.55	9.28	39.47	27.11	31.31	39.24
Z23325	7.28		20.10	10.05	45.08	31.19	35.18	44.53
Z26316	5.03		17.37	8.69	20.40	13.88	16.77	20.40
Z26318	5.66	14.50	19.52	9.44	26.16	17.60	21.03	26.16
Z26320	6.29		21.64	10.82	32.37	21.90	25.80	32.37
Z26323	7.23		24.80	12.40	43.04	28.78	33.30	42.22
Z30318	6.71	15.00	31.21	15.61	31.43	25.88	31.43	31.43
Z30320	7.46		34.63	17.32	38.74	31.35	38.37	38.74
Z20325	6.70		12.84	6.42	37.16	25.84	29.15	35.86
Z20327	7.23	15.50	13.82	6.90	40.77	28.74	32.34	39.47
Z23318	5.25		12.94	6.47	22.99	15.22	17.82	22.74
Z23320	5.83		14.35	7.18	28.53	18.86	21.16	27.67
Z23323	6.70	16.00	16.44	8.22	37.14	24.66	27.93	35.14
Z23325	7.28		17.81	8.90	42.43	28.43	31.96	39.84
Z26318	5.66		17.29	8.64	24.62	15.83	18.60	24.00
Z26320	6.29	16.50	19.17	9.13	30.83	19.78	22.90	29.48
Z26323	7.23		21.97	10.98	40.51	26.13	29.63	37.79
Z30318	6.71		27.65	13.82	29.58	23.05	28.20	29.58
Z30320	7.46	17.00	30.68	15.34	36.46	28.00	34.30	36.46
Z35318	8.23		47.64	23.82	35.67	35.67	35.67	35.67
Z35320	9.15		52.90	26.45	44.23	44.23	44.23	44.23

Section Reference	Weight (kg/m)	Span (m)	Design load in kN per span SLS deflection, ULS strength					
			Deflection check		Down load	Uplift load		
			L/180	L/360		0 sag	1 sag	2 sag
Z20323	6.17	9.00	10.57	5.29	31.54	21.02	23.36	28.90
Z20325	6.70		11.45	5.73	35.09	23.02	26.31	32.24
Z20327	7.23		12.32	6.16	38.50	26.44	29.23	35.50
Z23320	5.83	9.50	12.80	6.40	26.95	17.22	19.48	24.90
Z23323	6.70		14.66	7.33	35.07	22.60	25.10	31.55
Z23325	7.28		15.88	7.94	40.07	26.10	28.79	35.78
Z23327	7.86	10.00	17.10	8.55	45.06	29.65	32.52	39.96
Z26318	5.66		15.42	7.71	23.25	14.36	16.56	21.67
Z26320	6.29		17.10	8.55	29.11	18.01	20.42	26.52
Z26323	7.23	10.50	19.59	9.80	38.26	23.90	26.56	33.90

Z-SECTION PURLIN SYSTEM SINGLE/DOUBLE SPAN SLEEVED

Section Reference	Weight (kg/m)	Span (m)	Design load in kN per span SLS deflection, ULS strength						
			Deflection check		Down load	Uplift load			
			L/180	L/360		0 sag	1 sag	2 sag	
Z12315	2.81	4.00	9.21	4.60	19.08	19.08	19.08	19.08	
Z12316	3.00		9.80	4.90	20.98	20.98	20.98	20.98	
Z14313	2.79		12.44	6.22	17.39	17.39	17.39	17.39	
Z14314	3.00		13.38	6.69	20.05	20.05	20.05	20.05	
Z14315	3.22		14.32	7.16	22.84	22.84	22.84	22.84	
Z17313	3.18		20.34	10.17	20.54	20.54	20.54	20.54	
Z12315	2.81		4.50	7.27	3.64	16.96	16.96	16.96	16.96
Z12316	3.00			7.74	3.87	18.65	18.65	18.65	18.65
Z14313	2.79			9.83	4.91	15.46	15.46	15.46	15.46
Z14314	3.00			10.57	5.29	17.83	17.83	17.83	17.83
Z14315	3.22			11.32	5.66	20.31	20.31	20.31	20.31
Z14316	3.44			12.06	6.03	22.89	22.89	22.89	22.89
Z17313	3.18	16.07		8.04	18.26	18.26	18.26	18.26	
Z17314	3.43	17.30		8.65	21.19	21.19	21.19	21.19	
Z17315	3.68	18.52		9.26	24.27	24.27	24.27	24.27	
Z20313	3.48	23.33		11.67	20.44	20.44	20.44	20.44	
Z20314	3.15	25.12		12.56	23.85	23.85	23.85	23.85	
Z14313	2.79	5.00		7.96	3.98	13.91	13.91	13.91	13.91
Z14314	3.00		8.57	4.28	16.04	16.04	16.04	16.04	
Z14315	3.87		10.95	5.41	25.03	25.03	25.03	25.03	
Z17313	3.18		13.02	6.51	16.43	16.43	16.43	16.43	
Z17314	3.43		14.01	7.01	19.07	19.07	19.07	19.07	
Z17315	3.68		15.00	7.50	21.84	21.84	21.84	21.84	
Z17316	3.93		15.99	7.99	24.74	24.74	24.74	24.74	
Z17318	4.42		17.94	8.97	30.87	30.87	30.87	30.87	
Z20313	3.48		18.90	9.45	18.40	18.40	18.40	18.40	
Z20314	3.15		20.35	10.17	21.47	21.47	21.47	21.47	
Z20315	4.02		21.79	10.90	24.71	24.71	24.71	24.71	
Z23314	4.07		28.16	14.08	24.18	24.18	24.18	24.18	
Z12316	3.00	5.50	5.18	2.59	15.26	13.67	15.26	15.26	
Z14315	3.22		7.58	3.79	16.61	16.31	16.61	16.61	
Z14316	3.44		8.07	4.04	18.73	18.26	18.73	18.73	
Z14318	3.87		9.05	4.52	22.73	22.10	22.73	22.73	
Z14320	4.29		10.02	5.01	26.48	25.80	26.48	26.48	
Z17314	3.43		11.19	5.79	17.34	17.34	17.34	17.34	
Z17315	3.68		12.40	6.20	19.86	19.86	19.86	19.86	
Z17316	3.93		13.21	6.61	22.49	22.49	22.49	22.49	
Z17318	4.42		14.83	7.41	28.06	27.90	28.06	28.06	
Z20313	3.48		15.62	7.81	16.73	16.50	16.73	16.73	
Z20314	3.15		16.82	8.41	19.51	19.13	19.51	19.51	
Z20315	4.02		18.01	9.00	22.46	21.90	22.46	22.46	
Z20316	4.29	19.20	9.60	25.54	24.72	25.54	25.54		
Z23314	4.07	23.27	11.64	21.98	20.64	21.98	21.98		
Z23315	4.37	24.93	12.47	24.74	23.24	24.74	24.74		
Z23316	4.66	26.58	13.29	28.25	26.41	28.25	28.25		
Z17315	3.68	6.00	10.42	5.21	18.20	17.23	18.20	18.20	
Z17316	3.93		11.10	5.55	20.62	19.39	20.62	20.62	
Z17318	4.42		12.46	6.23	25.72	23.93	25.72	25.72	
Z20314	3.15		14.13	7.07	17.89	16.29	17.89	17.89	
Z20315	4.02		15.13	7.57	20.78	18.64	20.78	20.78	
Z20316	4.29		16.13	8.06	23.41	21.08	23.41	23.41	
Z20318	4.83		18.11	9.05	29.39	26.22	29.39	29.39	
Z20320	5.37		20.07	10.03	35.76	31.67	35.76	35.76	
Z23314	4.07		19.51	9.78	20.15	17.53	20.15	20.15	
Z23315	4.37		20.95	10.47	22.67	19.47	22.67	22.67	
Z23316	4.66		22.33	11.17	25.90	22.42	25.90	25.90	
Z23318	5.25		25.08	12.54	32.73	28.17	32.73	32.73	

Section Reference	Weight (kg/m)	Span (m)	Design load in kN per span SLS deflection, ULS strength					
			Deflection check		Down load	Uplift load		
			L/180	L/360		0 sag	1 sag	2 sag
Z17320	4.91	6.50	11.97	5.88	28.77	25.07	28.77	28.77
Z17323	5.64		13.45	6.73	34.99	30.87	34.99	34.99
Z20315	4.02		12.89	6.45	19.00	16.08	19.00	19.00
Z20316	4.29		13.74	6.87	21.61	18.21	21.61	21.61
Z20318	4.83		15.43	7.71	27.13	22.73	27.13	27.13
Z20320	5.37		17.10	8.55	33.01	27.55	33.01	33.01
Z20323	6.17		19.57	9.79	42.08	35.11	42.08	42.08
Z23314	4.07		16.66	8.33	18.60	15.05	18.22	18.60
Z23315	4.37		17.85	8.92	20.93	16.99	20.67	20.93
Z23316	4.66		19.03	9.51	23.91	19.34	23.66	23.91
Z23318	5.25		21.37	10.69	30.22	24.34	29.86	30.22
Z23320	5.83		23.69	11.85	36.96	29.70	36.33	36.96
Z30318	6.71	45.64	22.82	40.81	38.38	40.81	40.81	
Z17318	4.42	7.00	9.15	4.58	22.05	18.32	22.05	22.05
Z17320	4.91		10.14	5.07	26.71	22.15	26.71	26.71
Z20316	4.29		11.85	5.93	20.07	15.93	19.51	20.07
Z20318	4.83		13.30	6.65	25.19	19.96	24.32	25.19
Z20320	5.37		14.74	7.37	30.65	24.28	29.34	30.65
Z23315	4.37		15.39	7.70	19.43	14.77	18.09	19.43
Z23316	4.66		16.41	8.20	22.20	16.86	20.65	22.20
Z23318	5.25		18.43	9.21	28.06	21.31	26.01	28.06
Z23320	5.83		20.43	10.21	34.32	26.10	31.62	34.32
Z23323	6.70		23.39	11.70	43.98	33.67	40.28	43.98
Z26316	5.03		21.91	10.95	24.56	17.82	21.81	24.56
Z26318	5.66		24.61	12.30	30.65	22.37	27.34	30.65
Z26320	6.29	27.29	13.64	37.70	27.60	33.51	37.70	
Z30318	6.71	39.35	19.68	37.89	33.39	37.89	37.89	
Z20318	4.83	7.50	11.91	5.79	23.51	17.72	21.35	23.51
Z20320	5.37		12.84	6.42	28.61	21.64	25.78	28.61
Z20323	6.17		14.70	7.35	36.47	27.80	32.65	36.47
Z23316	4.66		14.29	7.15	20.72	14.86	18.11	20.72
Z23318	5.25		16.05	8.03	26.19	18.86	22.78	26.19
Z23320	5.83		17.80	8.90	32.03	23.20	27.71	32.03
Z23323	6.70		20.38	10.19	41.05	30.06	35.37	41.05
Z23325	7.28		22.08	11.04	46.54	34.52	40.31	46.54
Z26316	5.03		19.08	9.54	22.92	15.65	19.08	22.92
Z26318	5.66		21.44	10.72	28.61	19.74	23.91	28.61
Z26320	6.29		23.77	11.89	35.18	24.46	29.30	35.18
Z26323	7.23		27.24	13.62	45.36	31.99	37.72	45.36
Z30318	6.71	34.28	17.14	35.37	29.28	35.29	35.37	
Z30320	7.46	38.04	19.02	42.64	35.38	42.64	42.64	
Z20318	4.83	8.00	10.19	5.09	22.04	15.90	18.87	22.04
Z20320	5.37		11.29	5.64	26.82	19.47	22.82	26.82
Z20323	6.17		12.92	6.46	34.19	25.13	28.97	34.19
Z23318	5.25		14.11	7.05	24.55	16.87	20.09	24.55
Z23320	5.83		15.64	7.82	30.03	20.82	24.46	30.03
Z23323	6.70		17.91	8.96	38.48	27.11	31.31	38.48
Z23325	7.28		19.41	9.70	43.63	31.19	35.18	43.63
Z26316	5.03		16.77	8.39	21.49	13.88	16.77	21.09
Z26318	5.66		18.84	9.42	26.82	17.60	21.03	26.62
Z26320	6.29		20.89	10.45	32.98	21.90	25.80	32.81
Z26323	7.23		23.94	11.97	42.53	28.78	33.30	42.22
Z30318	6.71		30.13	15.07	33.15	25.88	31.51	33.15
Z30320	7.46	33.44	16.72	39.98	31.35	38.37	39.98	
Z20325	6.70	12.40	6.20	35.20	25.84	29.15	35.20	
Z20327	7.23	13.34	6.67	38.84	28.74	32.34	38.84	
Z23318	5.25	12.50	6.25	23.11	15.22	17.82	22.74	
Z23320	5.83	13.85	6.93	28.26	18.86	21.16	27.67	
Z23323	6.70	15.87	7.93	36.22	24.66	27.93	35.14	
Z23325	7.28	17.19	8.60	41.07	28.43	31.96	39.84	
Z26318	5.66	16.69	8.35	25.24	15.83	18.60	24.00	
Z26320	6.29	18.51	9.25	31.04	19.78	22.90	29.48	
Z26323	7.23	21.21	10.60	40.03	26.13	29.63	37.79	
Z26325	7.86	22.98	11.49	45.53	30.29	34.08	43.05	
Z30318	6.71	26.69	13.34	31.21	23.05	28.20	31.21	
Z30320	7.46	29.62	14.81	37.63	28.00	34.30	37.63	
Z30323	8.31	33.97	16.98	49.52	36.94	45.01	49.52	

Section Reference	Weight (kg/m)	Span (m)	Design load in kN per span SLS deflection, ULS strength					
			Deflection check		Down load	Uplift load		
			L/180	L/360		0 sag	1 sag	2 sag
Z20323	6.17	9.00	10.21	5.10	30.39	21.02	23.36	28.90
Z20325	6.70		11.06	5.53	33.61	23.02	26.31	32.24
Z20327	7.23		11.90	5.95	36.68	26.44	29.23	35.50
Z23320	5.83		12.31	6.18	26.69	17.22	19.48	24.90
Z23323	6.70		14.15	7.08	34.21	22.60	25.10	31.55
Z23325	7.28		15.33	7.67	38.79	26.10	28.79	35.78
Z26318	5.66		14.89	7.44	23.83	14.36	16.56	21.67
Z26320	6.29		16.51	8.25	29.32	18.01	20.42	26.52
Z26323	7.23		18.91	9.46	37.80	23.90	26.56	33.90
Z26325	7.86		20.50	10.25	43.00	27.76	30.62	38.60
Z30318	6.71		23.81	11.90	29.47	20.67	25.28	29.47
Z30320	7.46		26.42	13.21	35.54	25.19	30.74	35.54
Z30323	8.31	30.30	15.15	46.77	33.39	40.31	46.77	
Z30325	9.33	32.86	16.43	54.72	39.27	47.01	54.72	
Z23320	5.83	9.5						

Z-SECTION PURLIN SYSTEM

HEAVY END BAY SINGLE/DOUBLE SPAN – END BAY

Section Reference	Weight (kg/m)	Span (m)	Design load in kN per span SLS deflection, ULS strength						
			Deflection check		Down load	Uplift load			
			L/180	L/360		0 sag	1 sag	2 sag	
Z12315	2.81	4.00	9.21	4.60	19.08	19.08	19.08	19.08	
Z12316	3.00		9.80	4.90	20.98	20.98	20.98	20.98	
Z14313	2.79		12.44	6.22	17.39	17.39	17.39	17.39	
Z14314	3.00		13.38	6.69	20.05	20.05	20.05	20.05	
Z14315	3.22		14.32	7.16	22.84	22.84	22.84	22.84	
Z17313	3.18		20.34	10.17	20.54	20.54	20.54	20.54	
Z12315	2.81		4.50	7.27	3.64	16.96	16.96	16.96	16.96
Z12316	3.00			7.74	3.87	18.65	18.65	18.65	18.65
Z14313	2.79			9.83	4.91	15.46	15.46	15.46	15.46
Z14314	3.00			10.57	5.29	17.83	17.83	17.83	17.83
Z14315	3.22			11.32	5.66	20.31	20.31	20.31	20.31
Z14316	3.44			12.06	6.03	22.89	22.89	22.89	22.89
Z14318	3.87	13.52		6.93	27.81	27.81	27.81	27.81	
Z17313	3.18	16.07		8.04	18.26	18.26	18.26	18.26	
Z17314	3.43	17.30		8.65	21.19	21.19	21.19	21.19	
Z17315	3.68	18.52		9.26	24.27	24.27	24.27	24.27	
Z17316	3.93	19.74		9.87	27.49	27.49	27.49	27.49	
Z20313	3.48	23.33		11.67	20.44	20.44	20.44	20.44	
Z14313	2.79	5.00	7.96	3.98	13.91	13.91	13.91	13.91	
Z14314	3.00		8.57	4.28	16.04	16.04	16.04	16.04	
Z14315	3.22		9.17	4.40	18.20	18.20	18.20	18.20	
Z14316	3.44		9.76	4.88	20.60	20.60	20.60	20.60	
Z14318	3.87		10.95	5.41	25.03	25.03	25.03	25.03	
Z14320	4.29		12.12	6.06	29.13	29.13	29.13	29.13	
Z17313	3.18		13.02	6.51	16.43	16.43	16.43	16.43	
Z17314	3.43		14.01	7.01	19.07	19.07	19.07	19.07	
Z17315	3.68		15.00	7.50	21.84	21.84	21.84	21.84	
Z17316	3.93		15.99	7.99	24.74	24.74	24.74	24.74	
Z17318	4.42		17.94	8.97	30.87	30.87	30.87	30.87	
Z20313	3.48		18.90	9.45	18.40	18.40	18.40	18.40	
Z20314	3.15	20.35	10.17	21.47	21.47	21.47	21.47		
Z20315	4.02	21.79	10.90	24.71	24.71	24.71	24.71		
Z12316	3.00	5.50	5.18	2.59	15.26	13.67	15.26	15.26	
Z14315	3.22		7.58	3.79	16.61	16.61	16.61	16.61	
Z14316	3.44		8.07	4.04	18.73	18.73	18.73	18.73	
Z14318	3.87		9.05	4.52	22.73	22.73	22.73	22.73	
Z14320	4.29		10.02	5.01	26.48	26.48	26.48	26.48	
Z17314	3.43		11.19	5.79	17.34	17.34	17.34	17.34	
Z17315	3.68		12.40	6.20	19.86	19.86	19.86	19.86	
Z17316	3.93		13.21	6.61	22.49	22.49	22.49	22.49	
Z17318	4.42		14.83	7.41	28.06	28.06	28.06	28.06	
Z17320	4.91		16.42	8.21	34.00	34.00	34.00	34.00	
Z20313	3.48		15.62	7.81	16.73	16.50	16.73	16.73	
Z20314	3.15		16.82	8.41	19.51	19.13	19.51	19.51	
Z20315	4.02	18.01	9.00	22.46	21.90	22.46	22.46		
Z20318	4.83	21.55	10.70	32.06	30.66	32.06	32.06		
Z14320	4.29	6.00	8.42	4.21	24.28	22.30	24.28	24.28	
Z17315	3.68		10.42	5.21	18.20	17.23	18.20	18.20	
Z17316	3.93		11.10	5.55	20.62	19.39	20.62	20.62	
Z17318	4.42		12.46	6.23	25.72	23.93	25.72	25.72	
Z17320	4.91		13.80	6.90	31.17	28.74	31.17	31.17	
Z17323	5.64		15.79	7.89	37.91	35.27	37.91	37.91	
Z20314	3.15		14.13	7.07	17.89	16.29	17.89	17.89	
Z20315	4.02		15.13	7.57	20.78	18.64	20.78	20.78	
Z20316	4.29		16.13	8.06	23.41	21.08	23.41	23.41	
Z20318	4.83		18.11	9.05	29.39	26.22	29.39	29.39	
Z20320	5.37		20.07	10.03	35.76	31.67	35.76	35.76	
Z23314	4.07		19.51	9.78	20.15	17.53	20.15	20.15	
Z23315	4.37	20.95	10.47	22.67	19.47	22.67	22.67		
Z23316	4.66	22.33	11.17	25.90	22.42	25.90	25.90		
Z17316	3.93	6.50	9.46	4.73	19.03	16.81	19.03	19.03	
Z17318	4.42		10.62	5.31	23.75	20.81	23.75	23.75	
Z17320	4.91		11.97	5.88	28.77	25.07	28.77	28.77	
Z17323	5.64		13.45	6.73	34.99	30.87	34.99	34.99	
Z17325	6.12		14.56	7.28	38.43	34.38	38.43	38.43	
Z20315	4.02		12.89	6.45	19.00	16.08	19.00	19.00	
Z20316	4.29		13.74	6.87	21.61	18.21	21.61	21.61	
Z20318	4.83		15.43	7.71	27.13	22.73	27.13	27.13	
Z20320	5.37		17.10	8.55	33.01	27.55	33.01	33.01	
Z20323	6.17		19.57	9.79	42.08	35.11	42.08	42.08	
Z23314	4.07		16.66	8.33	18.60	15.05	18.60	18.60	
Z23315	4.37		17.85	8.92	20.93	16.99	20.93	20.93	
Z23316	4.66	19.03	9.51	23.91	19.34	23.66	23.91		
Z23318	5.25	21.37	10.69	30.22	24.34	29.86	30.22		
Z23320	5.83	23.69	11.85	36.96	29.70	36.33	36.96		

Section Reference	Weight (kg/m)	Span (m)	Design load in kN per span SLS deflection, ULS strength					
			Deflection check		Down load	Uplift load		
			L/180	L/360		0 sag	1 sag	2 sag
Z17318	4.42	7.00	9.15	4.58	22.05	18.32	22.05	22.05
Z17320	4.91		10.14	5.07	26.71	22.15	26.71	26.71
Z17323	5.64		11.60	5.80	32.49	27.36	32.49	32.49
Z17325	6.12		12.56	6.28	35.68	30.52	35.68	35.68
Z20316	4.29		11.85	5.93	20.07	15.93	19.51	20.07
Z20318	4.83		13.30	6.65	25.19	19.96	24.32	25.19
Z20320	5.37		14.74	7.37	30.65	24.28	29.34	30.65
Z20323	6.17		16.87	8.44	39.07	31.07	37.09	39.07
Z20325	6.70		18.28	9.14	43.21	34.91	41.52	43.21
Z23315	4.37		15.39	7.70	19.43	14.77	18.09	19.43
Z23316	4.66		16.41	8.20	22.20	16.86	20.65	22.20
Z23318	5.25		18.43	9.21	28.06	21.31	26.01	28.06
Z23320	5.83	20.43	10.21	34.32	26.10	31.62	34.32	
Z23323	6.70	23.39	11.70	43.98	33.67	40.28	43.98	
Z26316	5.03	21.91	10.95	24.56	17.82	21.81	24.56	
Z26318	5.66	24.61	12.30	30.65	22.37	27.34	30.65	
Z26320	6.29	27.29	13.64	37.70	27.60	33.51	37.70	
Z17318	4.42	7.50	7.97	3.99	20.58	16.32	19.62	20.58
Z17320	4.91		8.83	4.42	24.93	19.78	23.53	24.93
Z20318	4.83		11.91	5.79	23.51	17.72	21.35	23.51
Z20320	5.37		12.84	6.42	28.61	21.64	25.78	28.61
Z20323	6.17		14.70	7.35	36.47	27.80	32.65	36.47
Z20325	6.70		15.92	7.96	40.33	31.30	36.60	40.33
Z20327	7.23		17.13	8.57	44.02	34.73	40.48	44.02
Z23316	4.66		14.29	7.15	20.72	14.86	18.11	20.72
Z23318	5.25		16.05	8.03	26.19	18.86	22.78	26.19
Z23320	5.83		17.80	8.90	32.03	23.20	27.71	32.03
Z23323	6.70		20.38	10.19	41.05	30.06	35.37	41.05
Z23325	7.28		22.08	11.04	46.54	34.52	40.31	46.54
Z26316	5.03	19.08	9.54	22.92	15.65	19.08	22.92	
Z26318	5.66	21.44	10.72	28.61	19.74	23.91	28.61	
Z26320	6.29	23.77	11.89	35.18	24.46	29.30	35.18	
Z26323	7.23	27.24	13.62	45.36	31.99	37.72	45.36	
Z20318	4.83	8.00	10.19	5.09	22.04	15.90	18.87	22.04
Z20320	5.37		11.29	5.64	26.82	19.47	22.82	26.82
Z20323	6.17		12.92	6.46	34.19	25.13	28.97	34.19
Z20325	6.70		13.99	7.00	37.81	28.32	32.53	37.81
Z20327	7.23		15.06	7.53	41.27	31.47	36.03	41.27
Z23318	5.25		14.11	7.05	24.55	16.87	20.09	24.55
Z23320	5.83		15.64	7.82	30.03	20.82	24.46	30.03
Z23323	6.70		17.91	8.96	38.48	27.11	31.31	38.48
Z23325	7.28		19.41	9.70	43.63	31.19	35.18	43.63
Z23327	7.86		20.89	10.44	48.55	35.33	40.24	48.55
Z26316	5.03		16.77	8.39	21.49	13.88	16.77	21.09
Z26318	5.66		18.84	9.42	26.82	17.60	21.03	26.62
Z26320	6.29	20.89	10.45	32.98	21.90	25.80	32.81	
Z26323	7.23	23.94	11.97	42.53	28.78	33.30	42.22	
Z26325	7.86	25.95	12.97	48.37	33.29	38.22	48.15	
Z30318	6.71	30.13	15.07	33.15	25.88	31.51	33.15	
Z30320	7.46	33.44	16.72	39.98	31.35	38.37	39.98	
Z20320	5.37	8.50	10.00	5.00	25.24	17.68	20.35	25.24
Z20323	6.17		11.44	5.72	32.18	22.90	25.92	32.15
Z20325	6.70		12.40	6.20	35.20	25.84	29.15	35.20
Z20327	7.23		13.34	6.67	38.84	28.74	32.34	38.84
Z23318	5.25		12.50	6.25	23.11	15.22	17.82	22.74
Z23320	5.83		13.85	6.93	28.26	18.86	21.16	27.67
Z23323	6.70		15.87	7.93	36.22	24.66	27.93	35.14
Z23325	7.28		17.19	8.60	41.07	28.43	31.96	39.84
Z23327	7.86		18.50	9.25	45.88	32.25	36.04	44.53
Z26318	5.66		16.69	8.35	25.24	15.83	18.60	24.00
Z26320	6.29		18.51	9.25	31.04	19.78	22.90	29.48
Z26323	7.23		21.21	10.60	40.03	26.13	29.63	37.79
Z26325	7.86	22.98	11.49	45.53	30.29	34.08	43.05	
Z30318	6.71	26.69	13.34	31.21	23.05	28.20	31.21	
Z30320	7.46	29.62	14.81	37.63	28.00	34.30	37.63	
Z30323	8.31	33.97	16.98	49.52	36.94	45.01	49.52	

Z-SECTION PURLIN SYSTEM

HEAVY END BAY SINGLE SPAN – INNER BAY

Section Reference	Weight (kg/m)	Span (m)	Design load in kN per span SLS deflection, ULS strength					
			Deflection check		Down load	Uplift load		
			L/180	L/360		0 sag	1 sag	2 sag
Z12315	2.81	4.00	11.51	5.34	23.61	23.61	23.61	23.61
Z12316	3.00		12.25	6.13	25.90	25.90	25.90	25.90
Z14313	2.79		15.55	7.77	21.81	21.81	21.81	21.81
Z14314	3.00		16.73	8.37	25.05	25.05	25.05	25.05
Z14315	3.22		17.91	8.95	28.44	28.44	28.44	28.44
Z17313	3.18		25.43	12.71	26.06	26.06	26.06	26.06
Z12315	2.81		9.09	4.55	20.99	20.99	20.99	20.99
Z12316	3.00		9.68	4.84	23.02	23.02	23.02	23.02
Z14313	2.79		12.29	6.14	19.38	19.38	19.38	19.38
Z14314	3.00		13.22	6.61	22.26	22.26	22.26	22.26
Z14315	3.22		14.15	7.07	25.28	25.28	25.28	25.28
Z14316	3.44		15.07	7.54	28.42	28.42	28.42	28.42
Z14318	3.87	16.90	8.45	34.38	34.38	34.38	34.38	
Z17313	3.18	20.09	10.05	23.17	23.17	23.17	23.17	
Z17314	3.43	21.63	10.81	26.75	26.75	26.75	26.75	
Z17315	3.68	23.15	11.58	30.51	30.51	30.51	30.51	
Z17316	3.93	24.67	12.34	34.43	34.43	34.43	34.43	
Z20313	3.48	29.16	14.16	26.28	26.28	26.28	26.28	
Z14313	2.79	9.95	4.95	17.44	17.44	17.44	17.44	
Z14314	3.00	10.71	5.35	20.04	20.04	20.04	20.04	
Z14315	3.22	11.46	5.73	22.20	22.20	22.20	22.20	
Z14316	3.44	12.21	6.10	25.58	25.58	25.58	25.58	
Z14318	3.87	13.69	6.84	30.94	30.94	30.94	30.94	
Z14320	4.29	15.15	7.57	35.89	35.89	35.89	35.89	
Z17313	3.18	16.27	8.14	20.85	20.85	20.85	20.85	
Z17314	3.43	17.52	8.78	24.07	24.07	24.07	24.07	
Z17315	3.68	18.54	9.38	27.46	27.46	27.46	27.46	
Z17316	3.93	19.99	9.99	30.98	30.98	30.98	30.98	
Z17318	4.42	22.43	11.21	38.44	38.44	38.44	38.44	
Z20313	3.48	23.62	11.81	23.66	23.66	23.66	23.66	
Z20314	3.15	25.43	12.72	27.42	27.42	27.42	27.42	
Z20315	4.02	27.24	13.62	31.38	31.38	31.38	31.38	
Z12316	3.00	6.48	3.24	18.84	18.84	18.84	18.84	
Z14315	3.22	9.47	4.74	20.68	20.68	20.68	20.68	
Z14316	3.44	10.09	5.04	23.25	23.25	23.25	23.25	
Z14318	3.87	11.31	5.66	28.13	28.13	28.13	28.13	
Z14320	4.29	12.52	6.26	32.62	32.62	32.62	32.62	
Z17314	3.43	14.48	7.24	21.89	21.89	21.89	21.89	
Z17315	3.68	15.50	7.02	24.96	24.96	24.96	24.96	
Z17316	3.93	16.52	8.28	28.16	28.16	28.16	28.16	
Z17318	4.42	18.54	9.27	34.94	34.94	34.94	34.94	
Z17320	4.91	20.53	10.27	42.15	42.15	42.15	42.15	
Z20313	3.48	19.52	9.76	21.50	21.50	21.50	21.50	
Z20314	3.15	21.02	10.51	24.92	24.92	24.92	24.92	
Z20315	4.02	22.51	11.26	28.53	28.53	28.53	28.53	
Z20318	4.83	26.94	13.47	40.24	40.24	40.24	40.24	
Z14320	4.29	10.52	5.26	29.91	29.91	29.91	29.91	
Z17315	3.68	13.02	6.51	22.88	22.88	22.88	22.88	
Z17316	3.93	13.88	6.94	25.82	25.82	25.82	25.82	
Z17318	4.42	15.57	7.79	32.03	32.03	32.03	32.03	
Z17320	4.91	17.25	8.62	38.64	38.64	38.64	38.64	
Z17323	5.64	19.73	9.86	46.76	46.76	46.76	46.76	
Z20314	3.15	17.66	8.83	22.85	22.85	22.85	22.85	
Z20315	4.02	18.92	9.46	26.15	26.15	26.15	26.15	
Z20316	4.29	20.16	10.08	29.60	29.60	29.60	29.60	
Z20318	4.83	22.64	11.31	36.88	36.88	36.88	36.88	
Z20320	5.37	25.08	12.54	44.64	44.64	44.64	44.64	
Z23314	4.07	24.45	12.22	25.91	25.91	25.91	25.91	
Z23315	4.37	26.19	13.09	29.13	29.13	29.13	29.13	
Z23316	4.66	27.92	13.91	33.08	33.08	33.08	33.08	
Z17316	3.93	11.83	5.91	23.83	23.83	23.83	23.83	
Z17318	4.42	13.27	6.64	29.57	29.57	29.57	29.57	
Z17320	4.91	14.70	7.35	35.66	35.66	35.66	35.66	
Z17323	5.64	16.81	8.41	43.17	43.17	43.17	43.17	
Z17325	6.12	18.20	9.10	47.29	47.29	47.29	47.29	
Z20315	4.02	16.12	8.06	24.14	24.14	24.14	24.14	
Z20316	4.29	17.18	8.95	27.32	27.32	27.32	27.32	
Z20318	4.83	19.29	9.64	34.05	34.05	34.05	34.05	
Z20320	5.37	21.37	10.69	41.20	41.20	41.20	41.20	
Z20323	6.17	24.46	12.23	52.20	52.20	52.20	52.20	
Z23314	4.07	20.83	10.42	23.92	23.92	23.92	23.92	
Z23315	4.37	22.31	11.16	26.89	26.89	26.89	26.89	
Z23316	4.66	23.79	11.89	30.53	30.53	30.53	30.53	
Z23318	5.25	26.71	13.36	38.25	38.25	38.25	38.25	
Z23320	5.83	29.62	14.81	46.47	46.47	46.47	46.47	

Section Reference	Weight (kg/m)	Span (m)	Design load in kN per span SLS deflection, ULS strength					
			Deflection check		Down load	Uplift load		
			L/180	L/360		0 sag	1 sag	2 sag
Z17318	4.42	7.00	11.44	5.72	27.46	27.46	27.46	27.46
Z17320	4.91		12.67	6.34	33.12	33.12	33.12	33.12
Z17323	5.64		14.50	7.25	40.08	40.08	40.08	40.08
Z17325	6.12		15.69	7.85	43.91	43.91	43.91	43.91
Z20316	4.29		14.81	7.41	25.37	25.37	25.37	25.37
Z20318	4.83		16.63	8.31	31.61	31.61	31.61	31.61
Z20320	5.37		18.43	9.21	38.26	38.26	38.26	38.26
Z20323	6.17		21.09	10.55	48.47	48.47	48.47	48.47
Z20325	6.70		22.85	11.42	53.43	53.43	53.43	53.43
Z23315	4.37		19.24	9.62	24.97	24.97	24.97	24.97
Z23316	4.66		20.51	10.25	28.35	28.35	28.35	28.35
Z23318	5.25		23.03	11.52	35.52	35.52	35.52	35.52
Z23320	5.83	25.53	12.77	43.15	43.15	43.15	43.15	
Z23323	6.70	29.24	14.62	54.88	54.88	54.88	54.88	
Z26316	5.03	27.38	13.69	31.58	30.54	31.58	31.58	
Z26318	5.66	30.76	15.38	39.15	38.35	39.15	39.15	
Z26320	6.29	34.11	17.06	47.65	47.31	47.65	47.65	
Z17318	4.42	7.50	9.97	4.98	25.62	25.62	25.62	25.62
Z17320	4.91		11.04	5.52	30.91	30.91	30.91	30.91
Z20318	4.83		14.49	7.24	29.51	29.51	29.51	29.51
Z20320	5.37		16.05	8.03	35.71	35.71	35.71	35.71
Z20323	6.17		18.37	9.19	45.24	45.24	45.24	45.24
Z20325	6.70		19.90	9.95	49.87	49.87	49.87	49.87
Z20327	7.23		21.41	10.71	54.30	54.30	54.30	54.30
Z23316	4.66		17.87	8.93	26.46	25.47	26.46	26.46
Z23318	5.25		20.07	10.03	33.15	32.34	33.15	33.15
Z23320	5.83		22.24	11.12	40.27	39.76	40.27	40.27
Z23323	6.70		25.47	12.74	51.23	51.23	51.23	51.23
Z23325	7.28		27.60	13.80	57.86	57.86	57.86	57.86
Z26316	5.03	23.85	11.93	29.47	26.82	29.47	29.47	
Z26318	5.66	26.80	13.40	36.54	33.84	36.54	36.54	
Z26320	6.29	29.72	14.86	44.57	41.93	44.57	44.57	
Z26323	7.23	34.05	17.02	56.96	54.83	56.96	56.96	
Z20318	4.83	12.73	6.37	27.66	27.25	27.66	27.66	
Z20320	5.37	14.11	7.05	33.48	33.38	33.48	33.48	
Z20323	6.17	16.15	8.07	42.41	42.41	42.41	42.41	
Z20325	6.70	17.49	8.75	46.47	46.47	46.47	46.47	
Z20327	7.23	18.82	9.41	50.90	50.90	50.90	50.90	
Z23318	5.25	17.64	8.82	31.08	28.92	31.08	31.08	
Z23320	5.83	19.55	9.74	37.29	35.70	37.29	37.29	
Z23323	6.70	22.39	11.19	48.02	46.48	48.02	48.02	
Z23325	7.28	24.26	12.13	54.25	53.47	54.25	54.25	
Z23327	7.86	26.11	13.06	60.43	60.43	60.43	60.43	
Z26316	5.03	20.96	10.48	27.63	23.80	27.63	27.63	
Z26318	5.66	23.55	11.79	34.25	30.17	34.25	34.25	
Z26320	6.29	26.12	13.06	41.79	37.54	41.79	41.79	
Z26323	7.23	29.92	14.96	53.40	49.34	53.40	53.40	
Z26325	7.86	32.43	16.22	60.47	57.07	60.47	60.47	
Z30318	6.71	37.66	18.83	42.63	42.63	42.63	42.63	
Z30320	7.46	41.79	20.90	51.22	51.22	51.22	51.22	
Z20320	5.37	12.50	6.25	31.51	30.31	31.51	31.51	
Z20323	6.17	14.31	7.15	39.92	39.25	39.92	39.92	
Z20325	6.70	15.49	7.75	44.00	44.00	44.00	44.00	
Z20327	7.23	16.67	8.34	47.91	47.91	47.91	47.91	
Z23318	5.25	15.62	7.81	29.25	26.10	29.25	29.25	
Z23320	5.83	17.32	8.66	35.53	32.33	35.53	35.53	
Z23323	6.70	19.83	9.92	45.20	42.28	45.20	45.20	
Z23325	7.28	21.49	10.74	51.05	48.74	51.05	51.05	
Z23327	7.86	23.13	11.57	56.87	55.29	56.87	56.87	
Z26318	5.66	20.86	10.43	32.24	27.14	31.89	32.24	
Z26320	6.29	23.13	11.57	39.33	33.91	39.29	39.33	
Z26323	7.23	26.51	13.25	50.26	44.79	50.26	50.26	
Z26325	7.86	28.73	14.36	56.91	51.93	56.91	56.91	
Z30318	6.71	33.36	16.68	40.12	39.51	40.12	40.12	
Z30320	7.46	37.02	18.51	48.20	48.00	48.20	48.20	
Z30323	8.31	42.46	21.23	62.73	62.73	62.73	62.73	
Z23320	5.83	15.45	7.72	33.52				

Z-SECTION PURLIN SYSTEM

HEAVY END BAY DOUBLE SPAN – INNER BAY

Section Reference	Weight (kg/m)	Span (m)	Design load in kN per span SLS deflection, ULS strength					
			Deflection check		Down load	Uplift load		
			L/180	L/360		0 sag	1 sag	2 sag
Z12315	2.81	4.00	11.90	5.95	24.43	24.43	24.43	24.43
Z12316	3.00		12.68	6.34	26.90	26.90	26.90	26.90
Z14313	2.79		16.09	8.05	22.07	22.07	22.07	22.07
Z14314	3.00		17.31	8.66	25.52	25.52	25.52	25.52
Z14315	3.22		18.53	9.26	29.13	29.13	29.13	29.13
Z17313	3.18		26.31	13.16	25.85	25.85	25.85	25.85
Z12315	2.81		9.41	4.70	21.72	21.72	21.72	21.72
Z12316	3.00		10.02	5.01	23.91	23.91	23.91	23.91
Z14313	2.79		12.71	6.36	19.62	19.62	19.62	19.62
Z14314	3.00		13.68	6.84	22.68	22.68	22.68	22.68
Z14315	3.22		14.64	7.32	25.89	25.89	25.89	25.89
Z14316	3.44		15.60	7.80	29.25	29.25	29.25	29.25
Z14318	3.87	17.49	8.74	35.64	35.64	35.64	35.64	
Z17313	3.18	20.79	10.39	22.97	22.97	22.97	22.97	
Z17314	3.43	22.38	11.19	26.76	26.76	26.76	26.76	
Z17315	3.68	23.96	11.98	30.75	30.75	30.75	30.75	
Z17316	3.93	25.53	12.77	34.91	34.91	34.91	34.91	
Z20313	3.48	30.18	15.09	25.48	25.48	25.48	25.48	
Z14313	2.79	10.30	5.15	17.65	17.65	17.65	17.65	
Z14314	3.00	11.08	5.54	20.41	20.41	20.41	20.41	
Z14315	3.22	11.86	5.93	23.30	23.30	23.30	23.30	
Z14316	3.44	12.63	6.32	26.32	26.32	26.32	26.32	
Z14318	3.87	14.16	7.08	32.08	32.08	32.08	32.08	
Z14320	4.29	15.68	7.84	37.42	37.42	37.42	37.42	
Z17313	3.18	16.84	8.42	20.68	20.68	20.68	20.68	
Z17314	3.43	18.13	9.06	24.09	24.09	24.09	24.09	
Z17315	3.68	19.41	9.70	27.67	27.67	27.67	27.67	
Z17316	3.93	20.68	10.34	31.42	31.42	31.42	31.42	
Z17318	4.42	23.21	11.60	39.36	39.36	39.36	39.36	
Z20313	3.48	24.44	12.22	22.93	22.93	22.93	22.93	
Z20314	3.15	26.32	13.16	26.89	26.89	26.89	26.89	
Z20315	4.02	28.19	14.09	31.07	31.07	31.07	31.07	
Z12316	3.00	6.71	3.35	19.56	19.56	19.56	19.56	
Z14315	3.22	9.80	4.90	21.19	21.19	21.19	21.19	
Z14316	3.44	10.44	5.22	23.93	23.93	23.93	23.93	
Z14318	3.87	11.71	5.85	29.16	29.16	29.16	29.16	
Z14320	4.29	12.96	6.48	34.01	34.01	34.01	34.01	
Z17314	3.43	14.98	7.49	21.90	21.90	21.90	21.90	
Z17315	3.68	16.04	8.02	25.16	25.16	25.16	25.16	
Z17316	3.93	17.09	8.55	28.56	28.56	28.56	28.56	
Z17318	4.42	19.18	9.59	35.78	35.78	35.78	35.78	
Z17320	4.91	21.25	10.62	43.48	43.48	43.48	43.48	
Z20313	3.48	20.20	10.10	20.85	20.85	20.85	20.85	
Z20314	3.15	21.25	10.88	24.45	24.45	24.45	24.45	
Z20315	4.02	23.29	11.65	28.25	28.25	28.25	28.25	
Z20318	4.83	27.87	13.94	40.69	40.69	40.69	40.69	
Z14320	4.29	10.89	5.44	31.18	31.18	31.18	31.18	
Z17315	3.68	13.48	6.74	23.06	23.06	23.06	23.06	
Z17316	3.93	14.36	7.18	26.18	26.18	26.18	26.18	
Z17318	4.42	16.12	8.07	32.80	32.80	32.80	32.80	
Z17320	4.91	17.85	8.93	39.86	39.86	39.86	39.86	
Z17323	5.64	20.42	10.21	48.64	48.64	48.64	48.64	
Z20314	3.15	18.28	9.14	22.41	22.41	22.41	22.41	
Z20315	4.02	19.57	9.79	25.89	25.89	25.89	25.89	
Z20316	4.29	20.86	10.43	29.54	29.54	29.54	29.54	
Z20318	4.83	23.42	11.71	37.27	37.27	37.27	37.27	
Z20320	5.37	25.96	12.98	45.53	45.53	45.53	45.53	
Z23314	4.07	25.30	12.65	24.88	24.88	24.88	24.88	
Z23315	4.37	27.10	13.55	28.29	28.29	28.29	28.29	
Z23316	4.66	28.89	14.44	32.44	32.44	32.44	32.44	
Z17316	3.93	12.24	6.12	24.17	24.17	24.17	24.17	
Z17318	4.42	13.73	6.87	30.28	30.28	30.28	30.28	
Z17320	4.91	15.21	7.61	36.79	36.79	36.79	36.79	
Z17323	5.64	17.40	8.70	44.90	44.90	44.90	44.90	
Z17325	6.12	18.84	9.42	49.39	49.39	49.39	49.39	
Z20315	4.02	16.68	8.34	23.90	23.90	23.90	23.90	
Z20316	4.29	17.78	8.89	27.27	27.27	27.27	27.27	
Z20318	4.83	19.93	9.98	34.40	34.40	34.40	34.40	
Z20320	5.37	22.12	11.07	42.02	42.02	42.02	42.02	
Z20323	6.17	25.31	12.66	53.79	53.79	53.79	53.79	
Z23314	4.07	21.56	10.78	22.96	22.96	22.96	22.96	
Z23315	4.37	23.09	11.54	26.11	26.11	26.11	26.11	
Z23316	4.66	24.61	12.31	29.95	29.95	29.95	29.95	
Z23318	5.25	27.65	13.82	38.10	38.10	38.10	38.10	
Z23320	5.83	30.65	15.32	46.82	46.82	46.82	46.82	

Section Reference	Weight (kg/m)	Span (m)	Design load in kN per span SLS deflection, ULS strength					
			Deflection check		Down load	Uplift load		
			L/180	L/360		0 sag	1 sag	2 sag
Z17318	4.42	7.00	11.84	5.92	28.11	28.11	28.11	28.11
Z17320	4.91		13.12	6.50	34.16	34.16	34.16	34.16
Z17323	5.64		15.00	7.50	41.69	41.69	41.69	41.69
Z17325	6.12		16.24	8.12	45.86	45.86	45.86	45.86
Z20316	4.29		15.33	7.66	25.32	25.32	25.32	25.32
Z20318	4.83		17.21	8.60	31.95	31.95	31.95	31.95
Z20320	5.37		19.07	9.54	39.02	39.02	39.02	39.02
Z20323	6.17		21.83	10.91	49.94	49.94	49.94	49.94
Z20325	6.70		23.64	11.82	55.35	55.35	55.35	55.35
Z23315	4.37		19.91	9.95	24.24	24.24	24.24	24.24
Z23316	4.66		21.22	10.61	27.81	27.81	27.81	27.81
Z23318	5.25		23.84	11.92	35.38	35.38	35.38	35.38
Z23320	5.83	26.43	13.21	43.47	43.47	43.47	43.47	
Z23323	6.70	30.26	15.13	56.00	56.00	56.00	56.00	
Z26316	5.03	28.34	14.17	30.40	30.40	30.40	30.40	
Z26318	5.66	31.83	15.92	38.39	38.39	38.39	38.39	
Z26320	6.29	35.30	17.65	47.49	47.49	47.49	47.49	
Z17318	4.42	10.32	5.15	26.24	26.24	26.24	26.24	
Z17320	4.91	11.43	5.71	31.88	31.88	31.88	31.88	
Z20318	4.83	14.99	7.50	29.82	29.82	29.82	29.82	
Z20320	5.37	16.61	8.31	36.42	36.42	36.42	36.42	
Z20323	6.17	19.01	9.51	46.61	46.61	46.61	46.61	
Z20325	6.70	20.59	10.30	51.66	51.66	51.66	51.66	
Z20327	7.23	22.18	11.08	56.48	56.48	56.48	56.48	
Z23316	4.66	18.49	9.24	25.95	25.95	25.95	25.95	
Z23318	5.25	20.76	10.38	33.02	33.02	33.02	33.02	
Z23320	5.83	23.02	11.51	40.57	40.57	40.57	40.57	
Z23323	6.70	26.36	13.18	52.26	52.26	52.26	52.26	
Z23325	7.28	28.56	14.28	59.41	59.41	59.41	59.41	
Z26316	5.03	24.68	12.34	28.37	28.37	28.37	28.37	
Z26318	5.66	27.73	13.87	35.83	35.83	35.83	35.83	
Z26320	6.29	30.05	15.32	44.33	44.33	44.33	44.33	
Z26323	7.23	35.23	17.62	57.51	57.51	57.51	57.51	
Z20318	4.83	13.16	6.78	27.95	27.95	27.95	27.95	
Z20320	5.37	14.60	7.30	34.14	33.38	34.14	34.14	
Z20323	6.17	16.71	8.36	43.70	43.07	43.70	43.70	
Z20325	6.70	18.10	9.05	48.43	48.43	48.43	48.43	
Z20327	7.23	19.45	9.74	52.95	52.95	52.95	52.95	
Z23318	5.25	18.25	9.13	30.96	28.92	30.96	30.96	
Z23320	5.83	20.23	10.12	38.04	35.70	38.04	38.04	
Z23323	6.70	23.17	11.47	49.00	46.48	49.00	49.00	
Z23325	7.28	25.10	12.55	55.70	53.47	55.70	55.70	
Z23327	7.86	27.02	13.51	62.36	60.57	62.36	62.36	
Z26316	5.03	21.69	10.85	26.60	23.80	26.60	26.60	
Z26318	5.66	24.37	12.19	33.59	30.17	33.59	33.59	
Z26320	6.29	27.03	13.51	41.56	37.54	41.56	41.56	
Z26323	7.23	30.97	15.48	53.92	49.34	53.92	53.92	
Z26325	7.86	33.56	16.78	61.52	57.07	61.52	61.52	
Z30318	6.71	38.97	19.49	40.90	40.90	40.90	40.90	
Z30320	7.46	43.25	21.62	49.98	49.98	49.98	49.98	
Z20320	5.37	12.93	6.47	32.14	30.31	32.14	32.14	
Z20323	6.17	14.80	7.40	41.13	39.25	41.13	41.13	
Z20325	6.70	16.03	8.02	45.58	44.30	45.58	45.58	
Z20327	7.23	17.25	8.62	49.84	49.26	49.84	49.84	
Z23318	5.25	16.17	8.08	29.13	26.10	29.13	29.13	
Z23320	5.83	17.92	8.96	35.80	32.33	35.80	35.80	
Z23323	6.70	20.52	10.26	46.12	42.28	46.12	46.12	
Z23325	7.28	22.24	11.12	52.42	48.74	52.42	52.42	
Z23327	7.86	23.94	11.97	0.70	55.29	0.70	0.70	
Z26318	5.66	21.91	10.79	31.62	27.14	31.62	31.62	
Z26320	6.29	23.94	11.97	39.11	33.91	39.11	39.11	
Z26323	7.23	27.43	13.71	50.74	44.79	50.74	50.74	
Z26325	7.86	29.73	14.86	57.90	51.93	57.90	57.90	
Z30318	6.71	34.52	17.26	38.49	38.49	38.49	38.49	
Z30320	7.46	38.31	19.16	47.04	47.04	47.04	47.04	
Z30323	8.31	43.94	21.97	62.39	62.39	62.39	62.39	
Z23320	5.83	15.99	7.99	33.81	29.51			

C-SECTION PURLIN SYSTEM

SINGLE SPAN BUTTED

Section Reference	Weight (kg/m)	Span (m)	Design load in kN per span SLS deflection, ULS strength						
			Deflection check		Down load	Uplift load			
			L/180	L/360		0 sag	1 sag	2 sag	
C12315	2.81	4.00	4.79	2.39	14.55	8.45	12.49	14.16	
C12316	3.00		5.10	2.55	16.05	9.36	13.75	15.64	
C14313	2.79		6.47	3.23	12.99	8.37	12.43	12.99	
C14314	3.00		6.96	3.48	15.07	9.62	14.35	15.07	
C14315	3.22		7.45	3.72	17.25	10.92	16.34	17.25	
C17313	3.18		10.58	5.29	15.03	10.32	14.70	15.03	
C12315	2.81		4.50	3.78	1.89	12.93	7.04	10.13	11.93
C12316	3.00			4.03	2.01	14.27	7.83	11.16	13.16
C14313	2.79			5.11	2.56	11.55	6.82	10.32	11.28
C14314	3.00			5.50	2.75	13.40	7.87	11.88	13.10
C14315	3.22			5.89	2.94	15.34	8.97	13.47	15.00
C14316	3.44			6.27	3.13	17.36	10.12	15.12	16.96
C17313	3.18	8.36		4.18	13.36	8.31	12.38	13.05	
C17314	3.43	9.00		4.50	15.64	9.62	14.45	15.37	
C17315	3.68	9.63		4.82	18.04	11.01	16.58	17.79	
C20313	3.48	12.13		6.07	14.61	8.98	13.26	13.89	
C20314	3.75	13.06		6.53	17.25	10.46	15.64	16.54	
C14313	2.79	5.00		4.14	2.07	10.39	5.71	8.63	9.79
C14314	3.00		4.45	2.23	12.06	6.62	9.90	11.34	
C14315	3.22		4.77	2.38	13.80	7.57	11.22	12.95	
C14316	3.44		5.08	2.54	15.63	8.57	12.56	14.62	
C14318	3.87		5.69	2.85	19.12	10.56	15.19	17.81	
C17313	3.18		6.77	3.38	12.02	6.88	10.49	11.42	
C17314	3.43		7.29	3.64	14.08	7.99	12.19	13.42	
C17315	3.68		7.80	3.90	16.24	9.18	13.95	15.51	
C17316	3.93		8.31	4.16	18.50	10.42	15.76	17.68	
C17318	4.42		9.33	4.67	23.30	13.07	19.52	22.23	
C20313	3.48		9.83	4.91	13.15	7.37	11.27	12.17	
C20314	3.75		10.58	5.29	15.52	8.63	13.24	14.46	
C20315	4.02	11.33	5.67	18.03	9.96	15.28	16.88		
C23314	4.07	14.65	7.32	17.28	9.29	14.33	15.63		
C12316	3.00	5.50	2.70	1.35	11.67	5.87	7.75	9.49	
C14315	3.22		3.94	1.97	12.55	6.53	9.43	11.25	
C14316	3.44		4.20	2.10	14.21	7.41	10.56	12.66	
C14318	3.87		4.71	2.35	17.39	9.17	12.78	15.37	
C14320	4.29		5.21	2.60	20.34	10.88	14.93	17.94	
C17314	3.43		6.02	3.01	12.80	6.79	10.35	11.80	
C17315	3.68		6.45	3.22	14.76	7.82	11.81	13.60	
C17316	3.93		6.87	3.44	16.82	8.91	13.32	15.47	
C17318	4.42		7.71	3.86	21.18	11.24	16.45	19.37	
C20313	3.48		8.12	4.06	11.96	6.19	9.62	10.75	
C20314	3.75		8.74	4.37	14.11	7.28	11.25	12.74	
C20315	4.02		9.36	4.68	16.40	8.44	12.95	14.83	
C20316	4.29	9.98	4.99	18.79	9.67	14.70	17.01		
C23314	4.07	12.10	6.05	15.71	7.79	12.18	13.78		
C23315	4.37	12.96	6.48	17.69	8.88	13.82	15.70		
C23316	4.66	13.82	6.91	20.42	10.23	15.81	18.17		
C17315	3.68	6.00	5.42	2.71	13.53	6.80	10.07	11.98	
C17316	3.93		5.77	2.89	15.41	7.77	11.35	13.60	
C17318	4.42		6.48	3.24	19.42	9.85	14.02	16.95	
C20314	3.75		7.35	3.67	12.93	6.26	9.61	11.28	
C20315	4.02		7.87	3.93	15.03	7.29	11.04	13.10	
C20316	4.29		8.39	4.19	17.22	8.38	12.52	14.98	
C20318	4.83		9.42	4.71	21.89	10.73	15.59	18.90	
C20320	5.37		10.43	5.22	26.89	13.28	18.83	22.98	
C23314	4.07		10.17	5.09	14.40	6.66	10.40	12.21	
C23315	4.37		10.89	5.45	16.22	7.62	11.79	13.89	
C23316	4.66		11.61	5.81	18.72	8.82	13.45	16.04	
C23318	5.25		13.04	6.52	24.04	11.41	16.94	20.52	

Section Reference	Weight (kg/m)	Span (m)	Design load in kN per span SLS deflection, ULS strength					
			Deflection check		Down load	Uplift load		
			L/180	L/360		0 sag	1 sag	2 sag
C17320	4.91	6.50	6.12	3.06	21.87	10.79	14.50	17.86
C17323	5.64		6.99	3.50	26.82	13.57	17.86	21.81
C20315	4.02		6.70	3.35	13.87	6.40	9.48	11.60
C20316	4.29		7.15	3.57	15.90	7.38	10.74	13.23
C20318	4.83		8.02	4.01	20.21	9.50	13.39	16.61
C20320	5.37		8.89	4.45	24.82	11.81	16.19	20.12
C20323	6.17		10.18	5.09	31.96	15.49	20.55	25.43
C23314	4.07		8.67	4.33	13.29	5.79	8.92	10.85
C23315	4.37		9.28	4.64	14.97	6.65	10.11	12.34
C23316	4.66		9.90	4.95	17.28	7.72	11.53	14.20
C23318	5.25		11.11	5.56	22.19	10.06	14.50	18.07
C23320	5.83		12.32	6.16	27.45	12.62	17.66	22.10
C26316	5.03	13.21	6.61	18.89	8.08	12.30	15.20	
C17318	4.42	7.00	4.76	2.38	16.64	7.87	10.50	13.09
C17320	4.91		5.27	2.64	20.31	9.74	12.65	15.67
C20316	4.29		6.16	3.08	14.76	6.58	9.29	11.71
C20318	4.83		6.92	3.46	18.77	8.51	11.61	14.64
C20320	5.37		7.67	3.83	23.05	10.62	14.07	17.67
C23315	4.37		8.00	4.00	13.90	5.88	8.72	10.98
C23316	4.66		8.53	4.27	16.04	6.86	9.95	12.59
C23318	5.25		9.58	4.79	20.60	8.98	12.54	15.95
C23320	5.83		10.62	5.31	25.49	11.32	15.30	19.42
C23323	6.70		12.17	6.08	33.09	15.07	19.63	24.70
C26316	5.03		11.39	5.70	17.54	7.14	10.59	13.49
C26318	5.66		12.80	6.40	22.15	9.29	13.29	17.01
C26320	6.29	14.19	7.10	27.63	11.83	16.33	20.93	
C30318	6.71	20.46	10.23	27.08	12.70	19.90	23.14	
C20318	4.83	7.50	6.03	3.01	17.52	7.71	10.16	12.93
C20320	5.37		6.68	3.34	21.51	9.65	12.36	15.56
C20323	6.17		7.64	3.82	27.70	12.76	15.81	19.55
C23316	4.66		7.43	3.72	14.97	6.16	8.65	11.19
C23318	5.25		8.35	4.17	19.23	8.11	10.94	14.10
C23320	5.83		9.25	4.63	23.79	10.26	13.39	17.12
C23323	6.70		10.60	5.30	30.88	13.71	17.26	21.70
C23325	7.28		11.48	5.74	35.23	15.96	19.79	24.60
C26316	5.03		9.92	4.96	16.37	6.38	9.18	12.00
C26318	5.66		11.15	5.57	20.67	8.36	11.55	15.06
C26320	6.29		12.36	6.18	25.79	10.69	14.24	18.46
C26323	7.23		14.16	7.08	33.77	14.47	18.51	23.63
C30318	6.71	17.83	8.91	25.27	11.24	17.47	20.95	
C30320	7.46	19.78	9.89	30.66	13.96	21.24	25.68	
C20318	4.83	8.00	5.30	2.65	16.42	7.05	8.98	11.45
C20320	5.37		5.87	2.93	20.17	8.85	10.96	13.76
C20323	6.17		6.72	3.36	25.97	11.72	14.09	17.27
C23318	5.25		7.34	3.67	18.03	7.39	9.63	12.50
C23320	5.83		8.13	4.07	22.31	9.38	11.82	15.13
C23323	6.70		9.31	4.66	28.95	12.58	15.32	19.15
C23325	7.28		10.09	5.05	33.03	14.66	17.62	21.71
C26316	5.03		8.72	4.36	15.35	5.77	8.01	10.69
C26318	5.66		9.80	4.90	19.38	7.59	10.13	13.37
C26320	6.29		10.86	5.43	24.18	9.74	12.53	16.33
C26323	7.23		12.45	6.22	31.66	13.25	16.37	20.84
C30318	6.71		15.67	7.83	23.69	10.05	15.39	19.00
C30320	7.46	17.39	8.69	28.74	12.54	18.71	23.24	
C30325	8.58	24.35	12.18	36.30	16.66	23.13	28.82	
C20327	7.23	6.94	3.47	29.77	13.81	15.98	18.90	
C23318	5.25	6.50	3.25	16.97	6.78	8.55	11.11	
C23320	5.83	7.20	3.60	20.99	8.64	10.54	13.42	
C23323	6.70	8.25	4.13	27.25	11.62	13.72	16.97	
C23325	7.28	8.94	4.47	31.09	13.56	15.82	19.25	
C26318	5.66	8.68	4.34	18.24	6.95	8.95	11.88	
C26320	6.29	9.62	4.81	22.76	8.95	11.12	14.48	
C26323	7.23	11.03	5.51	29.80	12.22	14.61	18.46	
C26325	7.86	11.95	5.98	34.15	14.36	16.94	21.02	
C30318	6.71	13.88	6.94	22.30	9.08	13.61	17.26	
C30320	7.46	15.40	7.70	27.05	11.37	16.57	21.06	
C30323	8.58	17.66	8.83	36.30	15.66	21.78	27.82	

Section Reference	Weight (kg/m)	Span (m)	Design load in kN per span SLS deflection, ULS strength					
			Deflection check		Down load	Uplift load		
			L/180	L/360		0 sag	1 sag	2 sag
C20323	6.17	9.00	5.31	2.65	23.08	10.09	11.48	13.68
C20325	6.70		5.75	2.87	25.65	11.49	13.01	15.30
C20327	7.23		6.19	3.09	28.11	12.87	14.53	16.91
C23320	5.83		6.43	3.21	19.83	8.00	9.47	11.95
C23323	6.70		7.36	3.68	25.74	10.80	12.39	15.12
C23325	7.28		7.97	3.99	29.36	12.62	14.32	17.17
C26318	5.66		7.74	3.87	17.23	6.41	7.97	10.59
C26320	6.29		8.58	4.29	21.49	8.28	9.95	12.88
C26323	7.23		9.84	4.92	28.15	11.34	13.15	16.42
C26325	7.86		10.66	5.33	32.26	13.35	15.28	18.72
C30318	6.71		12.38	6.19	21.06	8.26	12.09	15.69
C30320	7.46		13.74	6.87	25.55	10.40	14.75	19.10
C30323	8.58	15.76	7.88	34.29	14.38	19.45	25.12	
C30325	9.33	17.09	8.54	40.50	17.30	22.79	29.25	
C23320	5.83	9.50	5.77	2.88	18.78	7.46	8.57	10.69

C-SECTION PURLIN SYSTEM DOUBLE SPAN BUTTED

Section Reference	Weight (kg/m)	Span (m)	Design load in kN per span SLS deflection, ULS strength					
			Deflection check		Down load	Uplift load		
			L/180	L/360		0 sag	1 sag	2 sag
C12315	2.81	4.00	9.54	4.77	19.90	17.83	19.90	19.90
C12316	3.00		10.15	5.08	21.97	19.65	21.97	21.97
C14313	2.79		12.88	6.44	17.67	17.67	17.67	17.67
C14314	3.00		13.86	6.93	20.54	20.54	20.54	20.54
C14315	3.22	4.50	14.84	7.42	23.54	23.54	23.54	23.54
C17313	3.18		21.07	10.54	20.34	20.34	20.34	20.34
C12315	2.81		7.53	3.77	17.69	14.60	17.69	17.69
C12316	3.00		8.02	4.01	19.53	16.14	19.53	19.53
C14313	2.79	5.00	10.18	5.09	15.71	14.88	15.71	15.71
C14314	3.00		10.95	5.48	18.25	17.03	18.25	18.25
C14315	3.22		11.72	5.86	20.93	19.26	20.93	20.93
C14316	3.44		12.49	6.24	23.72	21.58	23.72	23.72
C17313	3.18	5.50	16.65	8.32	18.08	18.08	18.08	18.08
C17314	3.43		17.92	8.96	21.22	21.22	21.22	21.22
C17315	3.68		19.19	9.59	24.52	24.20	24.52	24.52
C20313	3.48		24.17	12.08	19.66	19.66	19.66	19.66
C20314	3.75	6.00	26.02	13.01	23.28	23.28	23.28	23.28
C14313	2.79		8.25	4.12	14.14	12.32	14.14	14.14
C14314	3.00		8.87	4.44	16.43	14.13	16.43	16.43
C14315	3.22		9.50	4.75	18.84	16.02	18.84	18.84
C14316	3.44	6.50	10.12	5.06	21.35	19.99	21.35	21.35
C14318	3.87		11.34	5.67	26.17	21.88	26.17	26.17
C17313	3.18		13.49	6.74	16.27	15.25	16.27	16.27
C17314	3.43		14.52	7.26	19.09	17.58	19.09	19.09
C17315	3.68	7.00	15.54	7.77	22.07	20.00	22.07	22.07
C17316	3.93		16.56	8.28	25.18	22.52	25.18	25.18
C17318	4.42		18.59	9.29	31.79	27.83	31.79	31.79
C20313	3.48		19.58	9.79	17.69	16.62	17.69	17.69
C20314	3.75	7.50	21.08	10.54	20.95	19.28	20.95	20.95
C20315	4.02		22.57	11.29	24.40	22.06	24.40	24.40
C23314	4.07		29.17	14.59	22.95	21.07	22.95	22.95
C12316	3.00		5.37	2.69	15.98	11.72	13.57	15.98
C14315	3.22	8.00	7.85	3.92	17.12	13.61	16.51	17.12
C14316	3.44		8.36	4.18	19.41	15.32	18.49	19.41
C14318	3.87		9.37	4.69	23.79	18.71	22.37	23.79
C14320	4.29		10.38	5.19	27.87	22.01	26.14	27.87
C17314	3.43	8.50	12.00	6.00	17.36	14.77	17.36	17.36
C17315	3.68		12.84	6.42	20.06	16.85	20.06	20.06
C17316	3.93		13.69	6.84	22.89	19.02	22.89	22.89
C17318	4.42		15.36	7.68	28.90	23.60	28.90	28.90
C20313	3.48	9.00	16.18	8.09	16.08	13.89	16.08	16.08
C20314	3.75		17.42	8.71	19.04	16.14	19.04	19.04
C20315	4.02		18.65	9.33	22.18	18.50	22.18	22.18
C20316	4.29		19.88	9.94	25.48	20.97	25.48	25.48
C23314	4.07	9.50	24.11	12.06	20.86	17.56	20.86	20.86
C23315	4.37		25.82	12.91	23.82	19.83	23.82	23.82
C23316	4.66		27.53	13.77	27.56	22.59	27.56	27.56
C17315	3.68		10.79	5.40	18.39	14.44	17.63	18.39
C17316	3.93	10.00	11.50	5.75	20.98	16.34	19.86	20.98
C17318	4.42		12.91	6.45	26.49	20.38	24.53	26.49
C20314	3.75		14.64	7.32	17.46	13.73	16.82	17.46
C20315	4.02		15.67	7.84	20.33	15.78	19.32	20.33
C20316	4.29	10.50	16.71	8.35	23.35	17.94	21.90	23.35
C20318	4.83		18.76	9.38	29.78	22.54	27.29	29.78
C20320	5.37		20.79	10.39	36.65	27.48	32.95	36.65
C23314	4.07		20.26	10.13	19.12	14.87	18.20	19.12
C23315	4.37	11.00	21.70	10.85	21.83	16.84	20.63	21.83
C23316	4.66		23.13	11.57	25.26	19.24	23.54	25.26
C23318	5.25		25.98	12.99	32.57	24.36	29.64	32.57
C17320	4.91		11.50	12.18	6.09	29.89	21.74	25.38
C17323	5.64	13.93		6.97	36.72	27.03	31.25	36.72
C20315	4.02	13.36		6.68	18.77	13.67	16.58	18.77
C20316	4.29	14.24		7.12	21.56	15.58	18.79	21.56
C20318	4.83	12.00	15.98	7.99	27.49	19.68	23.43	27.49
C20320	5.37		17.71	8.86	33.83	24.09	28.33	33.83
C20323	6.17		20.27	10.14	43.67	31.07	35.96	43.67
C23314	4.07		17.26	8.63	17.65	12.78	15.61	17.65
C23315	4.37	12.50	18.49	9.24	20.15	14.51	17.69	20.15
C23316	4.66		19.71	9.86	23.32	16.63	20.17	23.32
C23318	5.25		22.14	11.07	30.07	21.17	25.38	30.07
C23320	5.83		24.54	12.27	37.31	26.10	30.90	37.31
C26316	5.03	13.00	26.32	13.16	25.18	17.70	21.53	25.18
C17318	4.42		9.48	4.74	22.71	15.87	18.38	22.71
C17320	4.91		10.50	5.25	27.76	19.38	22.14	27.43
C20316	4.29		12.27	6.14	20.02	13.72	16.26	20.02
C20318	4.83	13.50	13.78	6.89	25.52	17.41	20.31	25.52
C20320	5.37		15.27	7.64	31.42	21.40	24.62	30.91
C23315	4.37		15.94	7.97	18.71	12.68	15.26	18.71
C23316	4.66		17.00	8.50	21.65	14.57	17.41	21.65
C23318	5.25	14.00	19.09	9.54	27.92	18.66	21.94	27.91
C23320	5.83		21.16	10.58	34.65	23.10	26.77	33.99
C23323	6.70		24.23	12.12	45.11	30.18	34.36	43.22
C26316	5.03		22.69	11.35	23.38	15.44	18.53	23.38
C26318	5.66	14.50	25.49	12.75	29.89	19.63	23.26	29.76
C26320	6.29		28.27	14.13	37.43	24.48	28.58	36.62
C30318	6.71		40.76	20.38	35.93	28.49	34.83	35.93
C20318	4.83		12.00	6.00	23.82	15.58	17.79	22.63
C20320	5.37	15.00	13.30	6.65	29.32	19.22	21.63	27.23
C20323	6.17		15.23	7.61	37.85	25.02	27.68	34.22
C23316	4.66		14.81	7.40	20.21	12.92	15.14	19.58
C23318	5.25		16.63	8.31	26.06	16.63	19.14	24.68
C23320	5.83	15.50	18.43	9.22	32.34	20.68	23.42	29.96
C23323	6.70		21.11	10.56	42.10	27.15	30.20	37.97
C23325	7.28		22.87	11.44	48.10	31.36	34.64	43.05
C26316	5.66		19.77	9.88	21.82	13.63	16.06	21.00
C26320	6.29	16.00	22.21	11.10	27.90	17.43	20.22	26.36
C26323	7.23		24.62	12.31	34.94	21.84	24.92	32.31
C26325	7.86		28.21	14.11	45.92	28.96	32.39	41.35
C30318	6.71		35.51	17.76	33.53	24.98	30.57	33.53
C30320	7.46	16.50	39.41	19.70	41.32	30.43	37.17	41.32
C20318	4.83		10.55	5.28	22.33	14.08	15.72	20.04
C20320	5.37		11.69	5.85	27.49	17.44	19.18	24.07
C20323	6.17		13.38	6.69	35.49	22.77	24.66	30.22
C23318	5.25	17.00	14.61	7.31	24.43	14.98	16.85	21.88
C23320	5.83		16.20	8.10	30.32	18.70	20.69	26.48
C23323	6.70		18.55	9.28	39.47	24.66	26.81	33.50
C23325	7.28		20.10	10.05	45.10	28.53	30.83	37.99
C26316	5.03	17.50	17.37	8.69	20.46	12.16	14.02	18.70
C26320	6.29		19.52	9.76	26.16	15.63	17.73	23.39
C26323	7.23		21.64	10.82	32.75	19.69	21.93	28.57
C26325	7.86		24.80	12.40	43.05	26.23	28.65	36.47
C30318	6.71	18.00	31.21	15.61	31.43	22.12	26.92	31.43
C30320	7.46		34.63	17.32	38.74	27.05	32.75	38.74
C30325	8.58		42.84	21.42	37.16	23.67	25.08	29.98
C20327	7.23		13.82	6.91	40.77	26.41	27.97	33.08
C23318	5.25	18.50	12.95	6.47	22.99	13.61	14.95	19.44
C23320	5.83		14.35	7.18	28.53	17.05	18.44	23.49
C23323	6.70		16.44	8.22	37.15	22.58	24.02	29.70
C23325	7.28		17.81	8.90	42.44	26.17	27.69	33.69
C26318	5.66	19.00	17.29	8.64	24.62	14.15	15.67	20.79
C26320	6.29		19.17	9.59	30.83	17.90	19.47	25.34
C26323	7.23		21.97	10.98	40.52	23.96	25.57	32.30
C26325	7.86		23.81	11.90	46.52	27.94	29.64	36.79
C30318	6.71	19.50	27.65	13.82	29.59	19.76	23.81	29.59
C30320	7.46		30.68	15.34	36.46	24.26	29.00	36.46
C30323	8.58		35.19	17.59	49.18	32.50	38.12	48.68
C23325	7.28		20.00	17.18	8.90	26.17	14.15	15.67
C26320	6.29	19.17		9.59	30.83	17.90	19.47	25.34
C26323	7.23	21.97		10.98	40.52	23.96	25.57	32.30
C26325	7.86	23.81		11.90	46.52	27.94	29.64	36.79
C30318	6.71	20.50	27.65	13.82	29.59	19.76	23.81	29.59
C30320	7.46		30.68	15.34	36.46	24.26	29.00	36.46
C30323	8.58		35.19	17.59	49.18	32.50	38.12	48.68
C23325	7.28		21.00	17.18	8.90	26.17	14.15	15.67
C26320	6.29	19.17		9.59	30.83	17.90	19.47	25.34
C26323	7.23	21.97		10.98	40.52	23.96	25.57	32.30
C26325	7.86	23.81		11.90	46.52	27.94	29.64	36.79
C30318	6.71	21.50	27.65	13.82	29.59	19.76	23.81	29.59
C30320	7.46		30.68	15.34	36.46	24.26	29.00	36.46
C30323	8.58		35.19	17.59	49.18</			

C-SECTION PURLIN SYSTEM SIDE RAIL SYSTEM – SINGLE/DOUBLE SPAN SLEEVED

Section Reference	Weight (kg/m)	Span (m)	Design load in kN per span SLS deflection, ULS strength					
			Deflection check		Down load	Uplift load		
			L/180	L/360		0 sag	1 sag	2 sag
C12315	2.81	4.00	9.21	4.60	18.51	17.83	18.51	18.51
C12316	3.00		9.80	4.90	20.36	19.65	20.36	20.36
C14313	2.79		12.44	6.22	16.86	16.86	16.86	16.86
C14314	3.00		13.38	6.69	19.44	19.44	19.44	19.44
C14315	3.22	4.50	14.32	7.16	22.15	22.15	22.15	22.15
C17313	3.18		20.34	10.17	19.87	19.87	19.87	19.87
C12315	2.81		7.27	3.64	16.46	14.60	16.46	16.46
C12316	3.00		7.74	3.87	18.10	16.14	18.10	18.10
C14313	2.79	5.00	9.83	4.91	14.98	14.88	14.98	14.98
C14314	3.00		10.58	5.29	17.28	17.03	17.28	17.28
C14315	3.22		11.32	5.66	19.69	19.26	19.69	19.69
C14316	3.44		12.06	6.03	22.20	21.58	22.20	22.20
C17313	3.18	5.50	16.07	8.04	17.66	17.66	17.66	17.66
C17314	3.43		17.30	8.65	20.51	20.51	20.51	20.51
C17315	3.68		18.52	9.26	23.50	23.50	23.50	23.50
C20313	3.48		23.33	11.67	19.73	19.73	19.73	19.73
C20314	3.75	6.00	25.12	12.56	23.03	23.03	23.03	23.03
C14313	2.79		7.96	3.98	13.49	12.32	13.49	13.49
C14314	3.00		8.57	4.28	15.56	14.13	15.56	15.56
C14315	3.22		9.17	4.58	17.72	16.02	17.72	17.72
C14316	3.44	6.50	9.77	4.88	19.98	19.98	19.98	19.98
C14318	3.87		10.95	5.48	24.29	21.88	24.29	24.29
C17313	3.18		13.02	6.51	15.89	15.25	15.89	15.89
C17314	3.43		14.01	7.01	18.46	17.58	18.46	18.46
C17315	3.68	7.00	15.00	7.50	21.15	20.00	21.15	21.15
C17316	3.93		15.99	7.99	23.96	22.52	23.96	23.96
C17318	4.42		17.94	8.97	29.92	27.83	29.92	29.92
C20313	3.48		18.90	9.45	17.75	16.62	17.75	17.75
C20314	3.75	7.50	20.35	10.17	20.73	19.28	20.73	20.73
C20315	4.02		21.79	10.90	23.88	22.06	23.88	23.88
C23314	4.07		28.16	14.08	23.33	21.07	23.33	23.33
C12316	3.00		5.18	2.59	14.81	11.72	13.57	14.81
C14315	3.22	8.00	7.58	3.79	16.11	13.61	16.11	16.11
C14316	3.44		8.07	4.04	18.17	15.32	18.17	18.17
C14318	3.87		9.05	4.52	22.09	18.71	22.09	22.09
C14320	4.29		10.02	5.01	25.72	22.01	25.72	25.72
C17314	3.43	8.50	11.58	5.79	16.78	14.77	16.78	16.78
C17315	3.68		12.40	6.20	19.23	16.85	19.23	19.23
C17316	3.93		13.21	6.61	21.78	19.02	21.78	21.78
C17318	4.42		14.83	7.41	27.20	23.60	27.20	27.20
C20313	3.48	9.00	15.62	7.81	16.14	13.89	16.14	16.14
C20314	3.75		16.82	8.41	18.85	16.14	18.85	18.85
C20315	4.02		18.01	9.00	21.70	18.50	21.70	21.70
C20316	4.29		19.20	9.60	24.70	20.97	24.70	24.70
C23314	4.07	9.50	23.28	11.64	21.20	17.56	21.20	21.20
C23315	4.37		24.93	12.47	23.86	19.83	23.86	23.86
C23316	4.66		26.58	13.29	27.27	22.59	27.27	27.27
C17315	3.68		10.42	5.21	17.62	14.44	17.62	17.62
C17316	3.93	10.00	11.10	5.55	19.97	16.34	19.97	19.97
C17318	4.42		12.46	6.23	24.94	20.38	24.94	24.94
C20314	3.75		14.13	7.07	17.28	13.73	16.82	17.28
C20315	4.02		15.13	7.57	19.90	15.78	19.32	19.90
C20316	4.29	10.50	16.13	8.06	22.64	17.94	21.90	22.64
C20318	4.83		18.11	9.05	28.45	22.54	27.29	28.45
C20320	5.37		20.07	10.03	34.65	27.48	32.95	34.65
C23314	4.07		19.56	9.78	19.44	14.87	18.20	19.44
C23315	4.37	11.00	20.95	10.47	21.87	16.84	20.63	21.87
C23316	4.66		22.33	11.17	25.00	19.24	23.54	25.00
C23318	5.25		25.08	12.54	31.65	24.36	29.64	31.65
C17320	4.91		11.50	11.76	5.88	27.91	21.74	25.38
C17323	5.64	13.45		6.73	33.97	27.03	31.25	33.97
C20315	4.02	12.89		6.45	18.37	13.67	16.58	18.37
C20316	4.29	13.74		6.87	20.90	15.58	18.79	20.90
C20318	4.83	12.00	15.43	7.71	26.26	19.68	23.43	26.26
C20320	5.37		17.10	8.55	31.99	24.09	28.33	31.99
C20323	6.17		19.57	9.79	40.82	31.07	35.96	40.82
C23314	4.07		16.66	8.33	17.94	12.78	15.61	17.94
C23315	4.37	12.50	17.85	8.92	20.19	14.51	17.69	20.19
C23316	4.66		19.03	9.51	23.08	16.63	20.17	23.08
C23318	5.25		21.37	10.69	29.22	21.17	25.38	29.22
C23320	5.83		23.69	11.85	35.77	26.10	30.90	35.77
C30318	6.71	13.00	45.64	22.82	39.36	32.83	39.36	39.36
C17318	4.42		9.15	4.58	21.37	15.87	18.38	21.37
C17320	4.91		10.14	5.07	25.91	19.38	22.14	25.91
C20316	4.29		11.85	5.93	19.40	13.72	16.26	19.40
C20318	4.83	13.50	13.30	6.65	24.39	17.41	20.31	24.39
C20320	5.37		14.74	7.37	29.70	21.40	24.62	29.70
C23315	4.37		15.39	7.70	18.74	12.68	15.26	18.74
C23316	4.66		16.41	8.20	21.43	14.57	17.41	21.43
C23318	5.25	14.00	18.43	9.21	27.13	18.66	21.94	27.13
C23320	5.83		20.43	10.21	33.22	23.10	26.77	33.22
C23323	6.70		23.39	11.70	42.63	30.18	34.36	42.63
C26316	5.03		21.91	10.95	23.68	15.44	18.53	23.62
C26318	5.66	14.50	24.61	12.30	29.59	19.63	23.26	29.59
C26320	6.29		27.29	13.64	36.44	24.48	28.58	36.44
C30318	6.71		39.35	19.68	36.55	28.49	34.83	36.55
C20318	4.83		11.59	5.79	22.76	15.58	17.79	22.63
C20320	5.37	15.00	12.84	6.42	27.72	19.22	21.63	27.23
C20323	6.17		14.70	7.35	35.38	25.02	27.68	34.22
C23316	4.66		14.29	7.15	20.00	12.92	15.14	19.58
C23318	5.25		16.05	8.03	25.32	16.63	19.14	24.68
C23320	5.83	15.50	17.80	8.90	31.00	20.68	23.42	29.96
C23323	6.70		20.38	10.19	39.79	27.15	30.20	37.97
C23325	7.28		22.08	11.04	45.14	31.36	34.64	43.05
C26316	5.03		19.08	9.54	22.10	13.63	16.06	21.00
C26318	5.66	16.00	21.44	10.72	27.61	17.43	20.22	26.36
C26320	6.29		23.77	11.89	34.01	21.84	24.92	32.31
C26323	7.23		27.24	13.62	43.92	28.96	32.39	41.35
C30318	6.71		34.28	17.14	34.11	24.98	30.57	34.11
C30320	7.46	16.50	38.04	19.02	41.15	30.43	37.17	41.15
C20318	4.83		10.19	5.09	21.34	14.08	15.72	20.04
C20320	5.37		11.29	5.64	25.99	17.44	19.18	24.07
C20323	6.17		12.92	6.46	33.17	22.77	24.66	30.22
C23318	5.25	17.00	14.11	7.05	23.74	14.98	16.85	21.88
C23320	5.83		15.64	7.82	29.06	18.70	20.69	26.48
C23323	6.70		17.91	8.96	37.30	24.66	26.81	33.50
C23325	7.28		19.41	9.70	42.32	28.53	30.83	37.99
C26316	5.03	17.50	16.77	8.39	20.72	12.16	14.02	18.70
C26318	5.66		18.84	9.42	25.89	15.63	17.73	23.39
C26320	6.29		20.89	10.45	31.88	19.69	21.93	28.57
C26323	7.23		23.94	11.97	41.18	26.23	28.65	36.47
C30318	6.71	18.00	30.13	15.07	31.98	22.12	26.92	31.98
C30320	7.46		33.44	16.72	38.57	27.05	32.75	38.57
C20325	6.70		12.40	6.20	34.53	23.67	25.08	29.98
C20327	7.23		13.34	6.67	37.70	26.41	27.97	33.08
C23318	5.25	18.50	12.50	6.25	22.34	13.61	14.95	19.44
C23320	5.83		13.85	6.93	27.35	17.05	18.44	23.49
C23323	6.70		15.87	7.93	35.11	22.58	24.02	29.70
C23325	7.28		17.19	8.60	39.83	26.17	27.69	33.69
C26318	5.66	19.00	16.69	8.35	24.36	14.15	15.67	20.79
C26320	6.29		18.51	9.25	30.01	17.90	19.47	25.34
C26323	7.23		21.21	10.60	38.76	23.96	25.57	32.30
C26325	7.86		22.98	11.49	44.12	27.94	29.64	36.79
C30318	6.71	19.50	26.69	13.34	30.10	19.76	23.81	30.10
C30320	7.46		29.62	14.81	36.31	24.26	29.00	36.31
C30323	8.58		33.97	16.98	47.87	32.50	38.12	47.87
C23325	7.28		20.00	17.19	8.60	39.83	26.17	27.69
C26318	5.66	16.69		8.35	24.36	14.15	15.67	20.79
C26320	6.29	18.51		9.25	30.01	17.90	19.47	25.34
C26323	7.23	21.21		10.60	38.76	23.96	25.57	32.30
C26325	7.86	20.50	22.98	11.49	44.12	27.94	29.64	36.79
C30318	6.71		26.69	13.34	30.10	19.76	23.81	30.10
C30320	7.46		29.62	14.81	36.31	24.26	29.00	36.31
C30323	8.58		33.97	16.98	47.87	32.50	38.12	47.87

Section Reference	Weight (kg/m)	Span (m)	Design load in kN per span SLS deflection, ULS strength					
			Deflection check		Down load	Uplift load		
			L/180	L/360		0 sag	1 sag	2 sag
C20323	6.17	9.00	10.21	5.10	29.48	19.30	20.08	23.93
C20325	6.70		11.06	5.53	32.61	21.89	22.76	26.78
C20327	7.23		11.90	5.95	35.61	24.44	25.42	29.59
C23320	5							

C-SECTION PURLIN SYSTEM SIDE RAIL SYSTEM – HEAVY END BAY SINGLE SPAN

Section Reference	Weight (kg/m)	Span (m)	Design load in kN per span SLS deflection, ULS strength					
			Deflection check		Down load	Uplift load		
			L/180	L/360		0 sag	1 sag	2 sag
C12315	2.81	4.00	9.21	4.60	18.51	17.83	18.51	18.51
C12316	3.00		9.80	4.90	20.36	19.65	20.36	20.36
C14313	2.79		12.44	6.22	16.86	16.86	16.86	16.86
C14314	3.00		13.38	6.69	19.44	19.44	19.44	19.44
C14315	3.22		14.32	7.16	22.15	22.15	22.15	22.15
C17313	3.18		20.34	10.17	19.87	19.87	19.87	19.87
C12315	2.81		7.27	3.64	16.46	16.46	16.46	16.46
C12316	3.00		7.74	3.87	18.10	18.10	18.10	18.10
C14313	2.79		9.83	4.91	14.98	14.98	14.98	14.98
C14314	3.00		10.58	5.29	17.28	17.03	17.28	17.28
C14315	3.22		11.32	5.66	19.69	19.26	19.69	19.69
C14316	3.44		12.06	6.03	22.20	21.58	22.20	22.20
C14318	3.87	13.52	6.76	26.99	26.14	26.99	26.99	
C17313	3.18	16.07	8.04	17.66	17.66	17.66	17.66	
C17314	3.43	17.30	8.65	20.51	20.51	20.51	20.51	
C17315	3.68	18.52	9.26	23.50	23.50	23.50	23.50	
C17316	3.93	19.74	9.87	26.62	26.62	26.62	26.62	
C20313	3.48	23.33	11.67	19.73	19.73	19.73	19.73	
C14313	2.79	7.96	3.98	13.49	12.32	13.49	13.49	
C14314	3.00	8.57	4.28	15.56	14.13	15.56	15.56	
C14315	3.22	9.17	4.58	17.72	16.02	17.72	17.72	
C14316	3.44	9.77	4.88	19.98	17.99	19.98	19.98	
C14318	3.87	10.95	5.48	24.29	21.88	24.29	24.29	
C14320	4.29	12.12	6.06	28.29	25.66	28.29	28.29	
C17313	3.18	13.02	6.51	15.89	15.25	15.89	15.89	
C17314	3.43	14.01	7.01	18.46	17.58	18.46	18.46	
C17315	3.68	15.00	7.50	21.15	20.00	21.15	21.15	
C17316	3.93	15.99	7.99	23.96	22.52	23.96	23.96	
C17318	4.42	17.94	8.97	29.92	27.83	29.92	29.92	
C20313	3.48	18.90	9.45	17.75	16.62	17.75	17.75	
C20314	3.75	20.35	10.17	20.73	19.28	20.73	20.73	
C20315	4.02	21.79	10.90	23.88	22.06	23.88	23.88	
C12316	3.00	5.18	2.59	14.81	11.72	13.57	14.81	
C14315	3.22	7.58	3.79	16.11	13.61	16.11	16.11	
C14316	3.44	8.07	4.04	18.17	15.32	18.17	18.17	
C14318	3.87	9.05	4.52	22.09	18.71	22.09	22.09	
C14320	4.29	10.02	5.01	25.72	22.01	25.72	25.72	
C17314	3.43	11.58	5.79	16.78	14.77	16.78	16.78	
C17315	3.68	12.40	6.20	19.23	16.85	19.23	19.23	
C17316	3.93	13.21	6.61	21.78	19.02	21.78	21.78	
C17318	4.42	14.83	7.41	27.20	23.60	27.20	27.20	
C17320	4.91	16.42	8.21	32.98	28.50	32.98	32.98	
C20313	3.48	15.62	7.81	16.14	13.89	16.14	16.14	
C20314	3.75	16.82	8.41	18.85	16.14	18.85	18.85	
C20315	4.02	18.01	9.00	21.70	18.50	21.70	21.70	
C20316	4.29	19.20	9.60	24.70	20.97	24.70	24.70	
C20318	4.83	21.55	10.78	31.04	26.22	31.04	31.04	
C17315	3.68	10.42	5.21	17.62	14.44	17.62	17.62	
C17316	3.93	11.10	5.55	19.97	16.34	19.97	19.97	
C17318	4.42	12.46	6.23	24.94	20.38	24.94	24.94	
C17320	4.91	13.80	6.90	30.23	24.71	30.23	30.23	
C17323	5.64	15.79	7.89	36.80	30.61	36.12	36.80	
C20314	3.75	14.13	7.07	17.28	13.73	16.82	17.28	
C20315	4.02	15.13	7.57	19.90	15.78	19.32	19.90	
C20316	4.29	16.13	8.06	22.64	17.94	21.90	22.64	
C20318	4.83	18.11	9.05	28.45	22.54	27.29	28.45	
C20320	5.37	20.07	10.03	34.65	27.48	32.95	34.65	
C23314	4.07	19.56	9.78	19.44	14.87	18.20	19.44	
C23315	4.37	20.95	10.47	21.87	16.84	20.63	21.87	
C23316	4.66	22.33	11.17	25.00	19.24	23.54	25.00	
C17316	3.93	9.46	4.73	18.43	14.26	17.08	18.43	
C17318	4.42	10.62	5.31	23.02	17.87	21.12	23.02	
C17320	4.91	11.76	5.88	27.91	21.74	25.38	27.91	
C17323	5.64	13.45	6.73	33.97	27.03	31.25	33.97	
C17325	6.12	14.56	7.28	37.32	30.24	34.84	37.32	
C20315	4.02	12.89	6.45	18.37	13.67	16.58	18.37	
C20316	4.29	13.74	6.87	20.90	15.58	18.79	20.90	
C20318	4.83	15.43	7.71	26.26	19.68	23.43	26.26	
C20320	5.37	17.10	8.55	31.99	24.09	28.33	31.99	
C20323	6.17	19.57	9.79	40.82	31.07	35.96	40.82	
C23314	4.07	16.66	8.33	17.94	12.78	15.61	17.94	
C23315	4.37	17.85	8.92	20.19	14.51	17.69	20.19	
C23316	4.66	19.03	9.51	23.08	16.63	20.17	23.08	
C23318	5.25	21.37	10.69	29.22	21.17	25.38	29.22	
C23320	5.83	23.69	11.85	35.77	26.10	30.90	35.77	

Section Reference	Weight (kg/m)	Span (m)	Design load in kN per span SLS deflection, ULS strength					
			Deflection check		Down load	Uplift load		
			L/180	L/360		0 sag	1 sag	2 sag
C17318	4.42	7.00	9.15	4.58	21.37	15.87	18.38	21.37
C17320	4.91		10.14	5.07	25.91	19.38	22.14	25.91
C17323	5.64		11.60	5.80	31.54	24.17	27.35	31.54
C17325	6.12		12.56	6.28	34.66	27.07	30.55	34.66
C20316	4.29		11.85	5.93	19.40	13.72	16.26	19.40
C20318	4.83		13.30	6.65	24.39	17.41	20.31	24.39
C20320	5.37		14.74	7.37	29.70	21.40	24.62	29.70
C20323	6.17		16.87	8.44	37.91	27.73	31.37	37.91
C20325	6.70		18.28	9.14	41.93	31.30	35.29	41.93
C23315	4.37		15.39	7.70	18.74	12.68	15.26	18.74
C23316	4.66		16.41	8.20	21.43	14.57	17.41	21.43
C23318	5.25		18.43	9.21	27.13	18.66	21.94	27.13
C23320	5.83	20.43	10.21	33.22	23.10	26.77	33.22	
C23323	6.70	23.39	11.70	42.63	30.18	34.36	42.63	
C26316	5.03	21.91	10.95	23.68	15.44	18.53	23.62	
C26318	5.66	24.61	12.30	29.59	19.63	23.26	29.59	
C26320	6.29	27.29	13.64	36.44	24.48	28.58	36.44	
C17318	4.42	7.97	3.99	19.95	14.26	16.16	19.95	
C17320	4.91	8.83	4.42	24.18	17.46	19.52	24.16	
C20318	4.83	11.59	5.79	22.76	15.58	17.79	22.63	
C20320	5.37	12.84	6.42	27.72	19.22	21.63	27.23	
C20323	6.17	14.70	7.35	35.38	25.02	27.68	34.22	
C20325	6.70	15.92	7.96	39.13	28.27	31.19	38.18	
C20327	7.23	17.13	8.57	42.73	31.49	34.67	42.06	
C23316	4.66	14.29	7.15	20.00	12.92	15.14	19.58	
C23318	5.25	16.05	8.03	25.32	16.63	19.14	24.68	
C23320	5.83	17.80	8.90	31.00	20.68	23.42	29.96	
C23323	6.70	20.38	10.19	39.79	27.15	30.20	37.97	
C23325	7.28	22.08	11.04	45.14	31.36	34.64	43.05	
C26316	5.03	19.08	9.54	22.10	13.63	16.06	21.00	
C26318	5.66	21.44	10.72	27.61	17.43	20.22	26.36	
C26320	6.29	23.77	11.89	34.01	21.84	24.92	32.31	
C26323	7.23	27.24	13.62	43.92	28.96	32.39	41.35	
C20318	4.83	10.19	5.09	21.34	14.08	15.72	20.04	
C20320	5.37	11.29	5.64	25.99	17.44	19.18	24.07	
C20323	6.17	12.92	6.46	33.17	22.77	24.66	30.22	
C20325	6.70	13.99	7.00	36.69	25.77	27.85	33.74	
C20327	7.23	15.06	7.53	40.06	28.73	31.00	37.20	
C23318	5.25	14.11	7.05	23.74	14.98	16.85	21.88	
C23320	5.83	15.64	7.82	29.06	18.70	20.69	26.48	
C23323	6.70	17.91	8.96	37.30	24.66	26.81	33.50	
C23325	7.28	19.41	9.70	42.32	28.53	30.83	37.99	
C23327	7.86	20.89	10.44	47.30	32.46	34.91	42.47	
C26316	5.03	16.77	8.39	20.72	12.16	14.02	18.70	
C26318	5.66	18.84	9.42	25.89	15.63	17.73	23.39	
C26320	6.29	20.89	10.45	31.88	19.69	21.93	28.57	
C26323	7.23	23.94	11.97	41.18	26.23	28.65	36.47	
C26325	7.86	25.95	12.97	46.87	30.52	33.11	41.53	
C30318	6.71	30.13	15.07	31.98	22.12	26.92	31.98	
C30320	7.46	33.44	16.72	38.57	27.05	32.75	38.57	
C20320	5.37	10.00	5.00	24.46	15.94	17.16	21.37	
C20323	6.17	11.44	5.72	31.22	20.89	22.16	26.82	
C20325	6.70	12.40	6.20	34.53	23.67	25.08	29.98	
C20327	7.23	13.34	6.67	37.70	26.41	27.97	33.08	
C23318	5.25	12.50	6.25	22.34	13.61	14.95	19.44	
C23320	5.83	13.85	6.93	27.35	17.05	18.44	23.49	
C23323	6.70	15.87	7.93	35.11	22.58	24.02	29.70	
C23325	7.28	17.19	8.60	39.83	26.17	27.69	33.69	
C23327	7.86	18.50	9.25	44.51	29.81	31.41	37.69	
C26318	5.66	16.69	8.35	24.36	14.15	15.67	20.79	
C26320	6.29	18.51	9.25	30.01	17.90	19.47	25.34	
C26323	7.23	21.21	10.60	38.76	23.96	25.57	32.30	
C26325	7.86	22.98	11.49	44.12	27.94	29.64	36.79	
C30318	6.71	26.69	13.34	30.10	19.76	23.81	30.10	
C30320	7.46	29.62	14.81	36.31	24.26	29.00	36.31	
C30323	8.58	33.97	16.98	47.87	32.50	38.12	47.87	
C23320	5.83	12.36	6.18	25.84	15.66	16.57	20.92	
C23323	6.70	14.15						

APPENDIX A EXAMPLE COMPONENT DRAWINGS



Case Study

PROJECT

Wakefield Distribution Centre.

TONNAGE

374 tonnes total incl. accessories

EXAMPLE COMPONENT DRAWINGS 77

CMF Purlin / Rails 78

CMF Sleeves 82

CMF Cleats 86



CMF Accessories 98

APPENDIX A - COMPONENT DRAWINGS

CMF PURLIN / RAILS

Tekla Structures

GENERAL NOTES:-
 LENGTH OVER 16m SEEK ADVICE FROM CMF
 STANDARD HOLE PUNCHING FOR ALL SECTIONS, 18mm DIA
 ALL OUR SECTIONS ARE COLD FORMED FROM HOT DIPPED Z275
 GALVANISED S450GD STEEL TO BS EN 10346:2015 AND
 BS EN 10143:2006 WITH A MINIMUM YIELD STRENGTH OF 450N/mm²

 - SITE BOLTS
 - SITE C/SUNK NEARSIDE
 - SITE C/SUNK FARSIDE

SECTION A - A

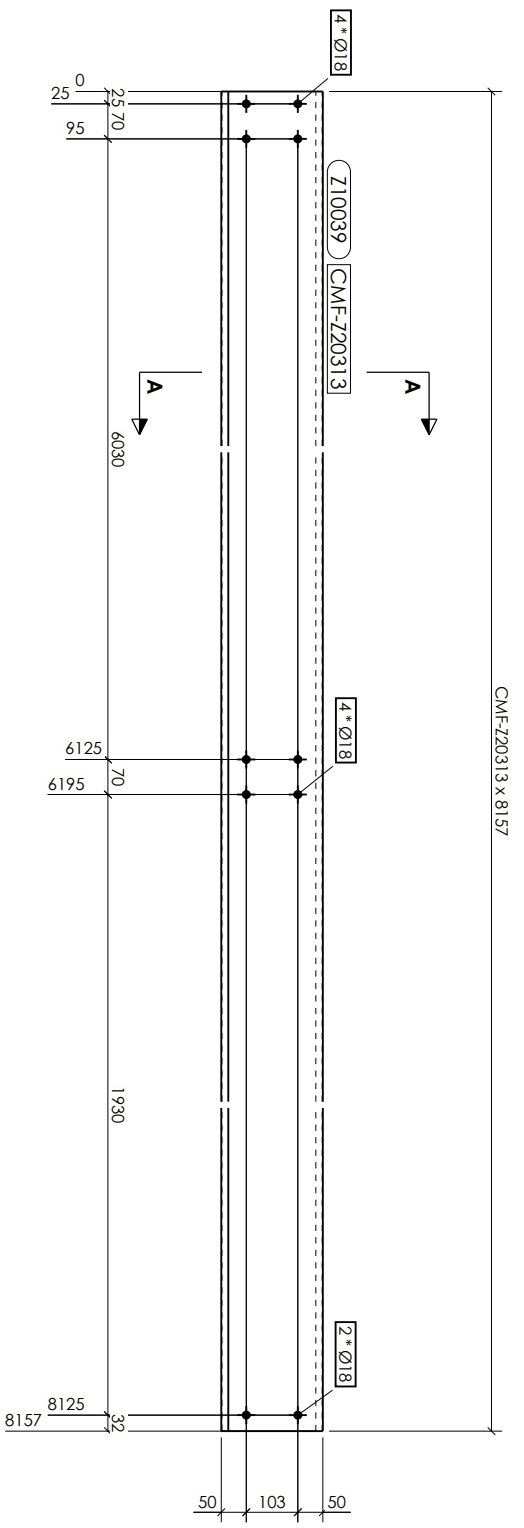

CMF PROFILE SIZE:- **CMF-Z20313** ALL DIMENSIONS IN MILLIMETRES - DO NOT SCALE - IF IN DOUBT ASK PRODUCT TYPE:- **PURLIN**

1 NO. ITEMS REQUIRED MARKED **Z10039**





Construction Metal Forming (Head Office)
 Unit 3, Marnlied Technology Park,
 Old Abingdon Road, Marnlied,
 Monmouthshire, NP24 0JJ
 Tel: 01493 61080
 Email: info@cmfuk.com
 Website: www.cmfuk.com



CLIENT: CMF	PROJECT: CMF Master Model
PROJECT ADDRESS: Construction Metal Forming (Head Office)	COMPONENT NAME: CMF_Z_SECTION
DRAWN BY: CMF	DATE: 06.01.2023
CONTRACT NUMBER 12345	DRAWING NUMBER Z10039
	SCALE: 1:12.5
	REVISION C01

Tekla Structures

GENERAL NOTES:-
 LENGTH OVER 16m SEEK ADVICE FROM CMF
 STANDARD HOLE PUNCHING FOR ALL SECTIONS, 18mm DIA
 ALL OUR SECTIONS ARE COLD FORMED FROM HOT DIPPED Z275
 GALVANISED S450GD STEEL TO BS EN 10346:2015 AND
 BS EN 10143:2006 WITH A MINIMUM YIELD STRENGTH OF 450N/mm²

 - SITE BOLTS
 - SITE C/SUNK NEARSIDE
 - SITE C/SUNK FARSIDE

SECTION A - A

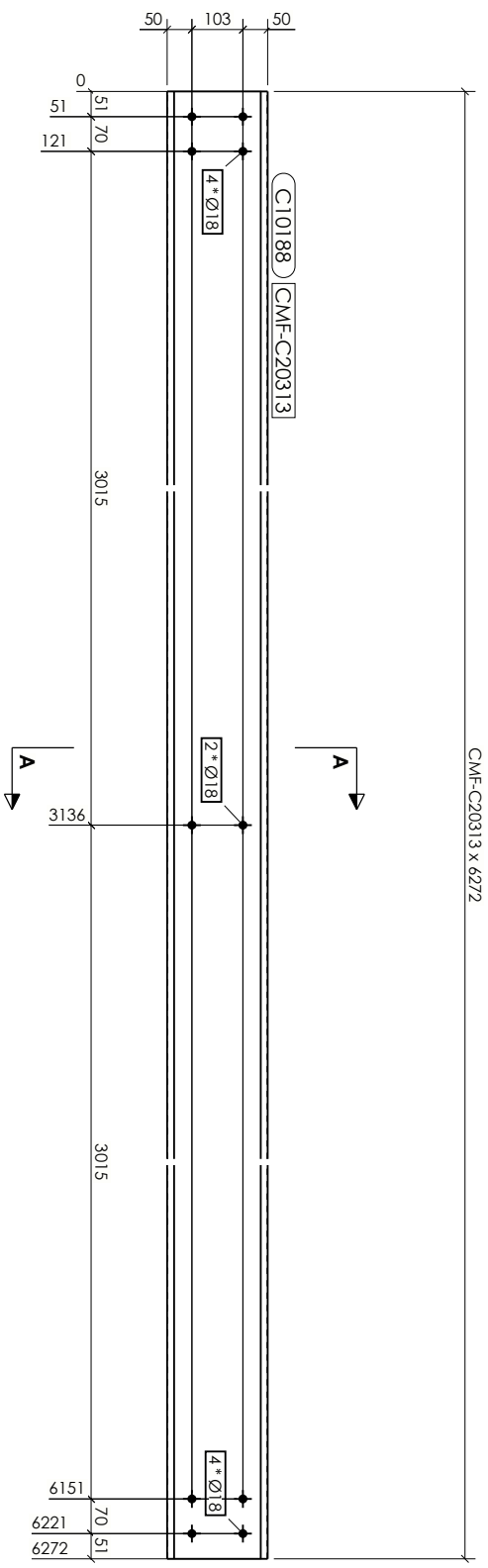

CMF PROFILE SIZE:- **CMF-C20313** ALL DIMENSIONS IN MILLIMETRES - DO NOT SCALE - IF IN DOUBT ASK PRODUCT TYPE:- **SIDERAIL**

1 NO. ITEMS REQUIRED MARKED **C10188**



Construction Metal Forming (Head Office)
 Unit 3, Marnlied Technology Park,
 Old Abingdon Road, Marnlied,
 Monmouthshire, NP24 0JJ
 Tel: 01493 61080
 Email: info@cmfuk.com
 Website: www.cmfuk.com



CLIENT: CMF	PROJECT: CMF Master Model
PROJECT ADDRESS: Construction Metal Forming (Head Office)	COMPONENT NAME: CMF_C_SECTION
DRAWN BY: CMF	DATE: 23.01.2023
CONTRACT NUMBER 12345	DRAWING NUMBER C10188
	SCALE: 1:12.5
	REVISION C01

APPENDIX A - COMPONENT DRAWINGS

CMF PURLIN / RAILS

<p>CMF PROFILE SIZE:- CMF-E20318+08</p> <p>ALL DIMENSIONS IN MILLIMETRES - DO NOT SCALE - IF IN DOUBT ASK</p> <p>PRODUCT TYPE:- EAVES BEAM</p>	<p style="text-align: right;">Tekla Structures</p> <p style="text-align: center;">SECTION A - A</p> <p style="text-align: center;">1 No. ITEMS REQUIRED MARKED EB10004</p> <p style="text-align: center;"></p> <p style="text-align: center;">Construction Metal Forming (Head Office) Unit 3, Marnlied Technology Park, Old Abeggweyny Road, Marnlied, Morrisonsville, (N4 01J) Tel: 01 493 61080 Email: info@cmfuk.com Website: www.cmfuk.com</p> <table border="1" style="width: 100%; border-collapse: collapse;"> <tr> <td colspan="2">CLIENT: CMF</td> </tr> <tr> <td colspan="2">PROJECT: CMF Master Model</td> </tr> <tr> <td colspan="2">PROJECT ADDRESS: Construction Metal Forming (Head Office)</td> </tr> <tr> <td colspan="2">COMPONENT NAME:- CMF EAVES BEAM (FLAT BACK)</td> </tr> <tr> <td>DRAWN BY: CMF</td> <td>DATE: 23.01.2023</td> </tr> <tr> <td>CONTRACT NUMBER 12345</td> <td>DRAWING NUMBER EB10004</td> </tr> <tr> <td></td> <td>SCALE: 1:12.5</td> </tr> <tr> <td></td> <td>REVISION C01</td> </tr> </table> <p>GENERAL NOTES:- LENGTH OVER 16m SEEK ADVICE FROM CMF STANDARD HOLE PUNCHING FOR ALL SECTIONS. 18mm DIA ALL OUR SECTIONS ARE COLD FORMED FROM HOT DIPPED Z275 GALVANISED S450GD STEEL TO BS EN 10346:2015 AND BS EN 10143:2006 WITH A MINIMUM YIELD STRENGTH OF 450N/mm²</p> <ul style="list-style-type: none"> - SITE BOLTS - SITE C/SUNK NEAR SIDE - SITE C/SUNK FAR SIDE 	CLIENT: CMF		PROJECT: CMF Master Model		PROJECT ADDRESS: Construction Metal Forming (Head Office)		COMPONENT NAME:- CMF EAVES BEAM (FLAT BACK)		DRAWN BY: CMF	DATE: 23.01.2023	CONTRACT NUMBER 12345	DRAWING NUMBER EB10004		SCALE: 1:12.5		REVISION C01
CLIENT: CMF																	
PROJECT: CMF Master Model																	
PROJECT ADDRESS: Construction Metal Forming (Head Office)																	
COMPONENT NAME:- CMF EAVES BEAM (FLAT BACK)																	
DRAWN BY: CMF	DATE: 23.01.2023																
CONTRACT NUMBER 12345	DRAWING NUMBER EB10004																
	SCALE: 1:12.5																
	REVISION C01																

<p>CMF PROFILE SIZE:- CMF-ES20018+08</p> <p>ALL DIMENSIONS IN MILLIMETRES - DO NOT SCALE - IF IN DOUBT ASK</p> <p>PRODUCT TYPE:- EAVES BEAM***</p>	<p style="text-align: right;">Tekla Structures</p> <p style="text-align: center;">SECTION A - A</p> <p style="text-align: center;">1 No. ITEMS REQUIRED MARKED EB10005</p> <p style="text-align: center;"></p> <p style="text-align: center;">Construction Metal Forming (Head Office) Unit 3, Marnlied Technology Park, Old Abeggweyny Road, Marnlied, Morrisonsville, (N4 01J) Tel: 01 493 61080 Email: info@cmfuk.com Website: www.cmfuk.com</p> <table border="1" style="width: 100%; border-collapse: collapse;"> <tr> <td colspan="2">CLIENT: CMF</td> </tr> <tr> <td colspan="2">PROJECT: CMF Master Model</td> </tr> <tr> <td colspan="2">PROJECT ADDRESS: Construction Metal Forming (Head Office)</td> </tr> <tr> <td colspan="2">COMPONENT NAME:- CMF EAVES BEAM (SIGMA)</td> </tr> <tr> <td>DRAWN BY: CMF</td> <td>DATE: 06.01.2023</td> </tr> <tr> <td>CONTRACT NUMBER 12345</td> <td>DRAWING NUMBER EB10005</td> </tr> <tr> <td></td> <td>SCALE: 1:20</td> </tr> <tr> <td></td> <td>REVISION C01</td> </tr> </table> <p>GENERAL NOTES:- LENGTH OVER 16m SEEK ADVICE FROM CMF STANDARD HOLE PUNCHING FOR ALL SECTIONS. 18mm DIA ALL OUR SECTIONS ARE COLD FORMED FROM HOT DIPPED Z275 GALVANISED S450GD STEEL TO BS EN 10346:2015 AND BS EN 10143:2006 WITH A MINIMUM YIELD STRENGTH OF 450N/mm²</p> <ul style="list-style-type: none"> - SITE BOLTS - SITE C/SUNK NEAR SIDE - SITE C/SUNK FAR SIDE 	CLIENT: CMF		PROJECT: CMF Master Model		PROJECT ADDRESS: Construction Metal Forming (Head Office)		COMPONENT NAME:- CMF EAVES BEAM (SIGMA)		DRAWN BY: CMF	DATE: 06.01.2023	CONTRACT NUMBER 12345	DRAWING NUMBER EB10005		SCALE: 1:20		REVISION C01
CLIENT: CMF																	
PROJECT: CMF Master Model																	
PROJECT ADDRESS: Construction Metal Forming (Head Office)																	
COMPONENT NAME:- CMF EAVES BEAM (SIGMA)																	
DRAWN BY: CMF	DATE: 06.01.2023																
CONTRACT NUMBER 12345	DRAWING NUMBER EB10005																
	SCALE: 1:20																
	REVISION C01																

APPENDIX A - COMPONENT DRAWINGS

CMF SLEEVES

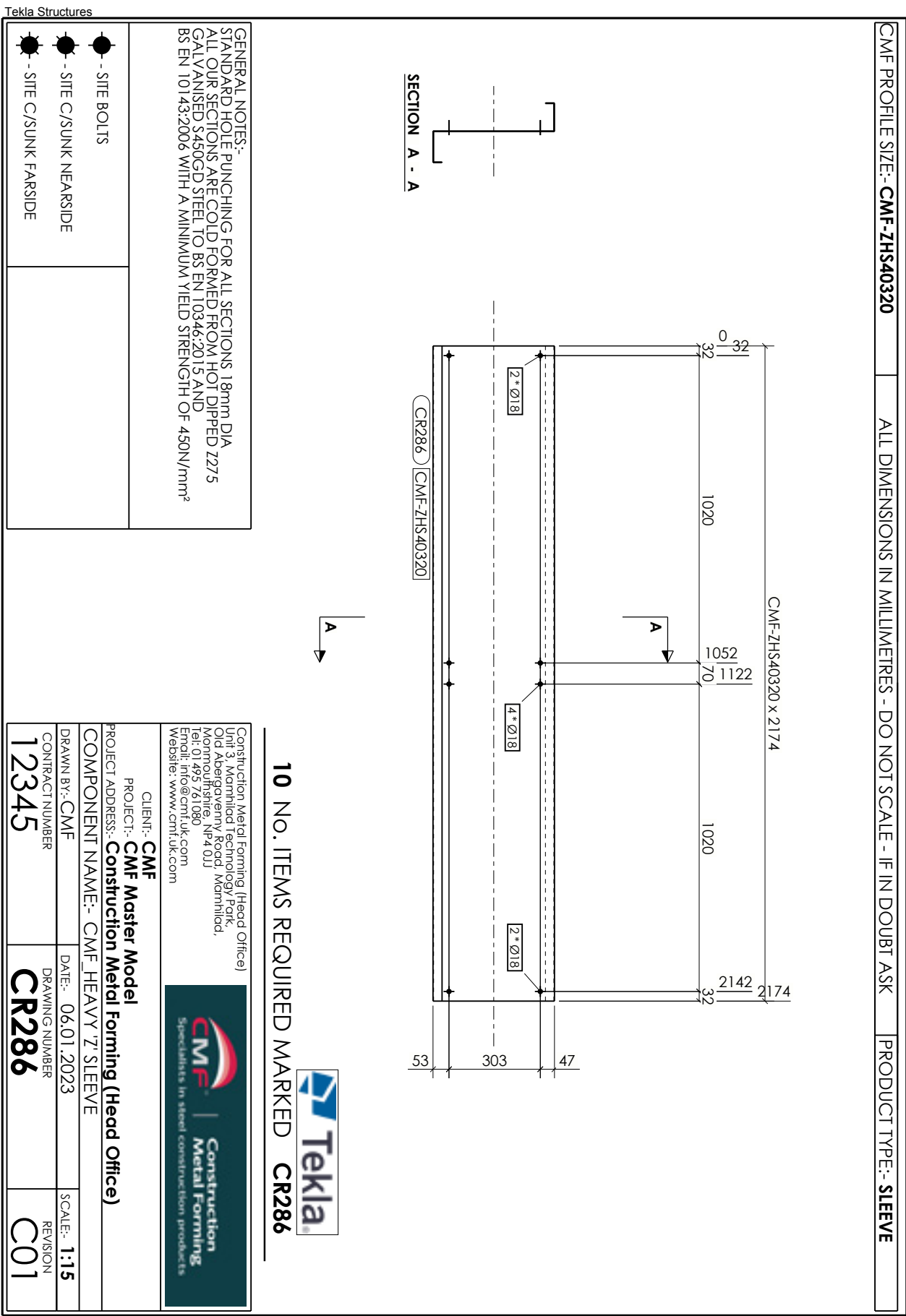
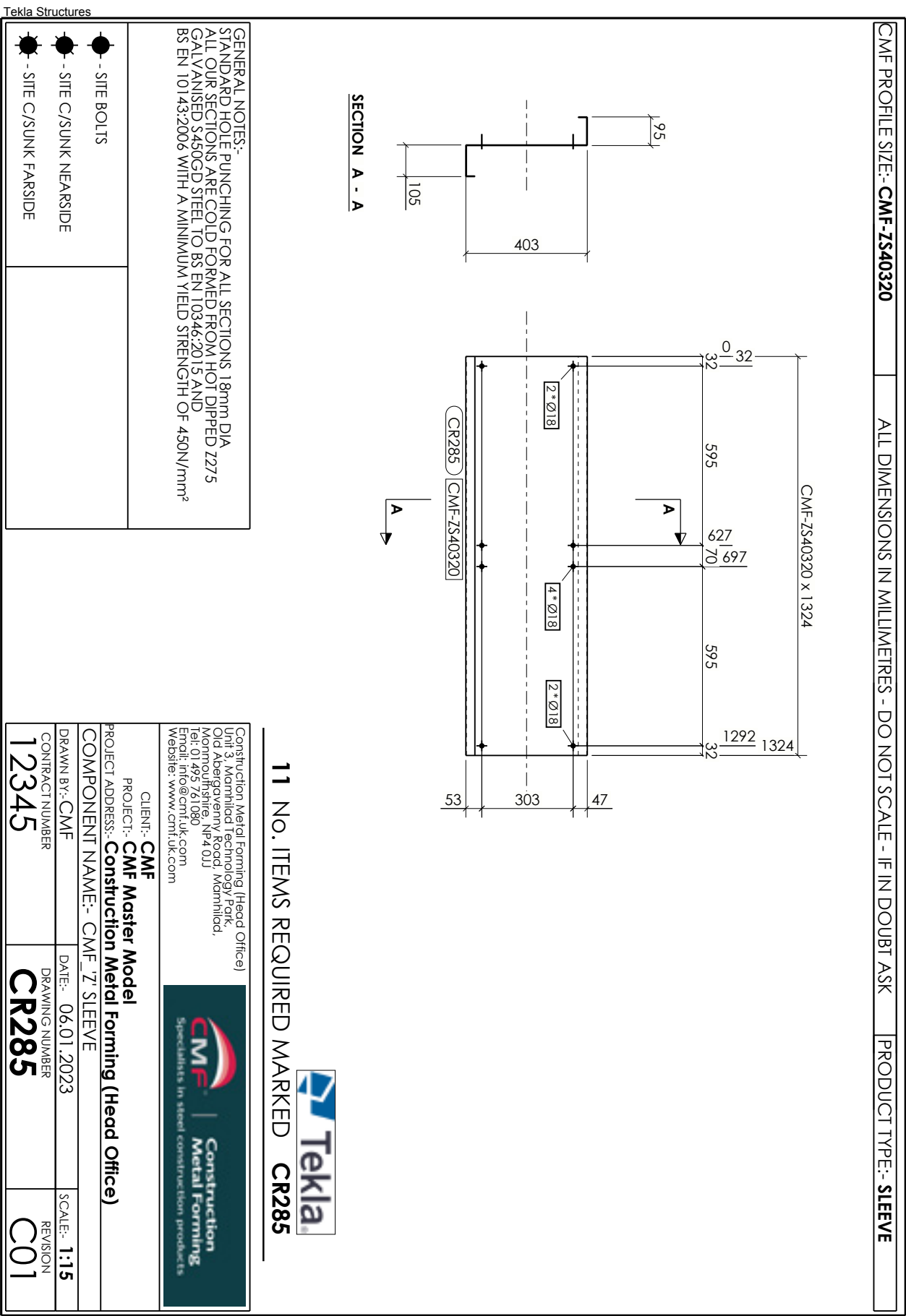

APPENDIX A - COMPONENT DRAWINGS

CMF SLEEVES

Tekla Structures

- - SITE BOLTS
- - SITE C/SUNK NEAR SIDE
- - SITE C/SUNK FAR SIDE

GENERAL NOTES:-
STANDARD HOLE PUNCHING FOR ALL SECTIONS, 18mm DIA
ALL OUR SECTIONS ARE COLD FORMED FROM HOT DIPPED Z275
GALVANISED S450GD STEEL TO BS EN 10344:2015 AND
BS EN 10143:2006 WITH A MINIMUM YIELD STRENGTH OF 450N/mm²

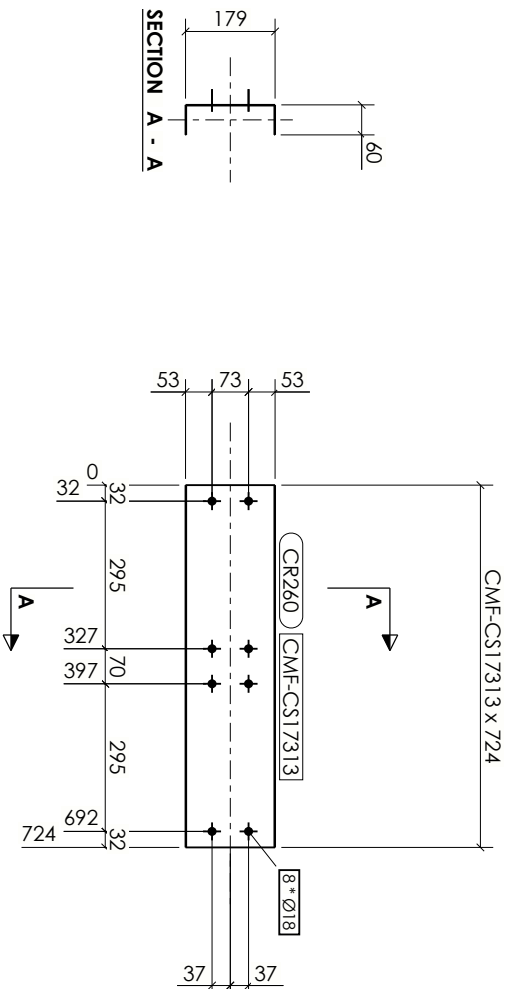

CMF PROFILE SIZE:- **CMF-CS17313**

ALL DIMENSIONS IN MILLIMETRES - DO NOT SCALE - IF IN DOUBT ASK

PRODUCT TYPE:- **SLEEVE**

5 NO. ITEMS REQUIRED MARKED **CR260**



Construction Metal Forming (Head Office)
Unit 3, Marnlied Technology Park,
Old Abergavenny Road, Marnlied,
Monmouthshire, NP24 0JJ
Tel: 01493 61080
Email: info@cmfuk.com
Website: www.cmfuk.com



CLIENT: CMF	PROJECT: CMF Master Model
PROJECT ADDRESS: Construction Metal Forming (Head Office)	COMPONENT NAME: CMF 'C' SLEEVE
DRAWN BY: CMF	DATE: 06.01.2023
CONTRACT NUMBER: 12345	DRAWING NUMBER: CR260
	SCALE: 1:12.5
	REVISION: C01

Tekla Structures

- - SITE BOLTS
- - SITE C/SUNK NEAR SIDE
- - SITE C/SUNK FAR SIDE

GENERAL NOTES:-
LENGTH OVER 16m SEEK ADVICE FROM CMF
STANDARD HOLE PUNCHING FOR ALL SECTIONS, 18mm DIA
ALL OUR SECTIONS ARE COLD FORMED FROM HOT DIPPED Z275
GALVANISED S450GD STEEL TO BS EN 10344:2015 AND
BS EN 10143:2006 WITH A MINIMUM YIELD STRENGTH OF 450N/mm²

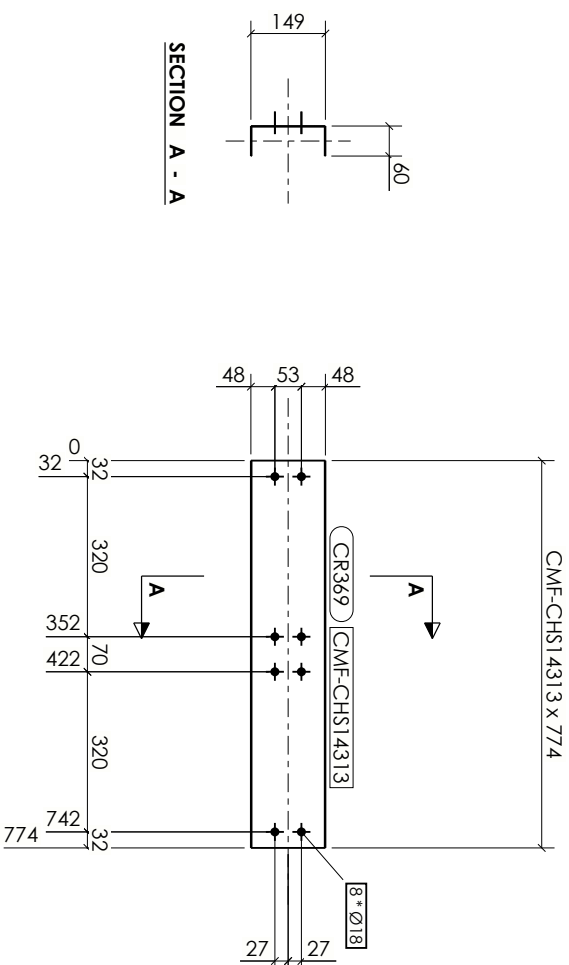

CMF PROFILE SIZE:- **CMF-CHS14313**

ALL DIMENSIONS IN MILLIMETRES - DO NOT SCALE - IF IN DOUBT ASK

PRODUCT TYPE:- **SLEEVE**

1 NO. ITEMS REQUIRED MARKED **CR369**



Construction Metal Forming (Head Office)
Unit 3, Marnlied Technology Park,
Old Abergavenny Road, Marnlied,
Monmouthshire, NP24 0JJ
Tel: 01493 61080
Email: info@cmfuk.com
Website: www.cmfuk.com





CLIENT: CMF	PROJECT: CMF Master Model
PROJECT ADDRESS: Construction Metal Forming (Head Office)	COMPONENT NAME: CMF HEAVY 'C' SLEEVE
DRAWN BY: CMF	DATE: 06.01.2023
CONTRACT NUMBER: 12345	DRAWING NUMBER: CR369
	SCALE: 1:12.5
	REVISION: C01

APPENDIX A - COMPONENT DRAWINGS

CMF CLEATS

Tekla Structures

-  - SITE BOLTS
-  - SITE C/SUNK NEARSIDE
-  - SITE C/SUNK FARSIDE

GENERAL NOTES:-
 STANDARD HOLE PUNCHING FOR ALL SECTIONS 18mm DIA
 ALL OUR CLEATS ARE HOT ROLLED STEEL GRADE S355JR
 ALL WELD ON CLEATS ARE SUPPLIED BLACK
 ALL BOLT ON CLEATS CAN BE SUPPLIED BLACK OR
 GALVANISED TO 85 MICRONS

SECTION SIZE	DIM 'A'	DIM 'B'	DIM 'T'	DIM 'H'
123	53	42	6	120
143	53	52	6	130
173	73	57	6	155
203	103	57	6	185
233	133	57	8	215
263	163	57	8	245
303	203	57	10	285
353	253	57	10	335
403	303	57	10	385

CMF PROFILE SIZE:- **CMF-BC-123*6**

ALL DIMENSIONS IN MILLIMETRES - DO NOT SCALE - IF IN DOUBT ASK

PRODUCT TYPE:- **CLEAT**

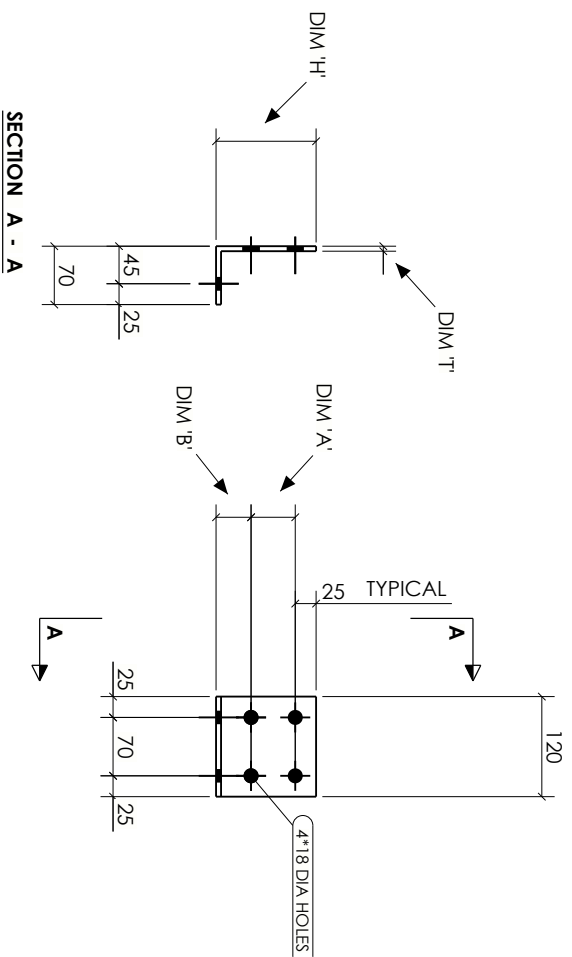

1 NO. ITEMS REQUIRED MARKED **BC10**





Construction Metal Forming (Head Office)
 Unit 3, Marnlidia Technology Park,
 Old Abergavenny Road, Marnlidia,
 Monmouthshire, NP24 0JJ
 Tel: 01495 261080
 Email: info@cmfuk.com
 Website: www.cmfuk.com



CLIENT:	CMF
PROJECT:	CMF Master Model
PROJECT ADDRESS:	Construction Metal Forming (Head Office)
COMPONENT NAME:	CMF_CLEAT BOLTED (BC-123 TO BC-403)
DRAWN BY:	CMF
DATE:	23.01.2023
CONTRACT NUMBER	12345
DRAWING NUMBER	BC10
SCALE:	1:7.5
REVISION	C01

Tekla Structures

-  - SITE BOLTS
-  - SITE C/SUNK NEARSIDE
-  - SITE C/SUNK FARSIDE

GENERAL NOTES:-
 STANDARD HOLE PUNCHING FOR ALL SECTIONS 18mm DIA
 ALL OUR CLEATS ARE HOT ROLLED STEEL GRADE S355JR
 ALL WELD ON CLEATS ARE SUPPLIED BLACK
 ALL BOLT ON CLEATS CAN BE SUPPLIED BLACK OR
 GALVANISED TO 85 MICRONS

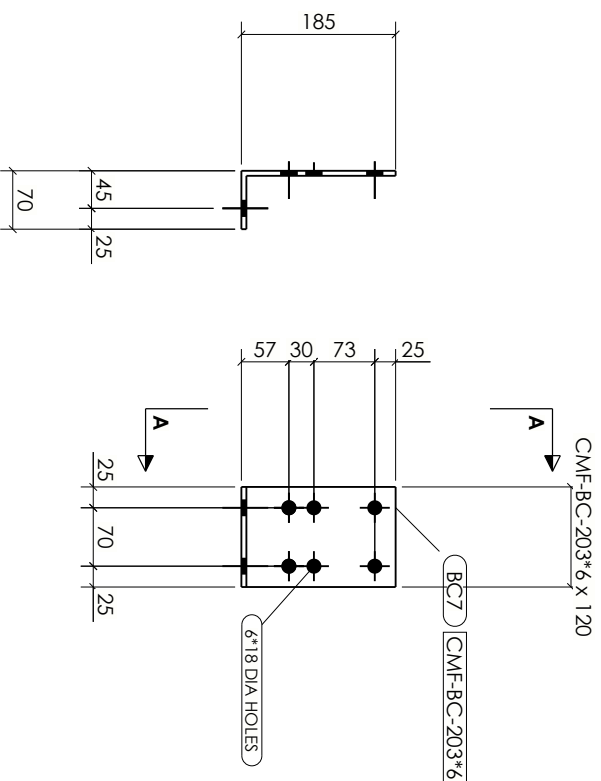

SECTION A - A

1 NO. ITEMS REQUIRED MARKED **BC7**



Construction Metal Forming (Head Office)
 Unit 3, Marnlidia Technology Park,
 Old Abergavenny Road, Marnlidia,
 Monmouthshire, NP24 0JJ
 Tel: 01495 261080
 Email: info@cmfuk.com
 Website: www.cmfuk.com



CLIENT:	CMF
PROJECT:	CMF Master Model
PROJECT ADDRESS:	Construction Metal Forming (Head Office)
COMPONENT NAME:	CMF_CLEAT BOLTED (MBOC-203)
DRAWN BY:	CMF
DATE:	23.01.2023
CONTRACT NUMBER	12345
DRAWING NUMBER	BC7
SCALE:	1:7.5
REVISION	C01

APPENDIX A - COMPONENT DRAWINGS

CMF CLEATS

Tekla Structures

GENERAL NOTES:-
 STANDARD HOLE PUNCHING FOR ALL SECTIONS 18mm DIA
 ALL OUR CLEATS ARE HOT ROLLED STEEL GRADE S355JR
 ALL WELD ON CLEATS ARE SUPPLIED BLACK
 ALL BOLT ON CLEATS CAN BE SUPPLIED BLACK OR GALVANISED TO 85 MICRONS

- - SITE BOLTS
- - SITE C/SUNK NEAR SIDE
- - SITE C/SUNK FAR SIDE

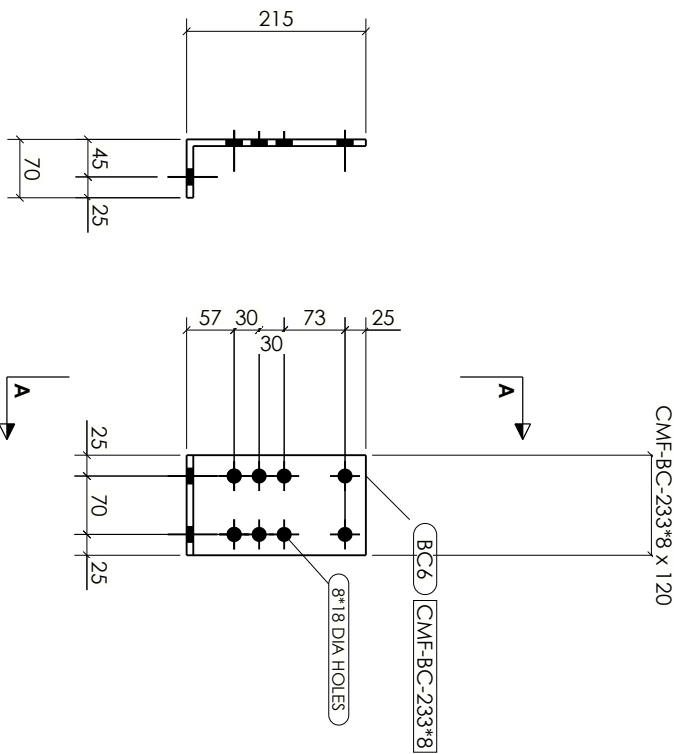

SECTION A - A

CMF PROFILE SIZE:- **CMF-BC-233*8**

ALL DIMENSIONS IN MILLIMETRES - DO NOT SCALE - IF IN DOUBT ASK

PRODUCT TYPE:- **CLEAT**

1 NO. ITEMS REQUIRED MARKED **BC6**



Construction Metal Forming (Head Office)
 Unit 3, Marnlidia Technology Park,
 Old Abergavenny Road, Marnlidia,
 Monmouthshire, NP24 0JJ
 Tel: 01495 261080
 Email: info@cmfuk.com
 Website: www.cmfuk.com



CLIENT:- CMF	PROJECT:- CMF Master Model		
PROJECT ADDRESS:- Construction Metal Forming (Head Office)	COMPONENT NAME:- CMF_CLEAT BOLTED (MBOC-233)		
DRAWN BY:- CMF	DATE:- 23.01.2023	DRAWING NUMBER	SCALE:- 1:7.5
CONTRACT NUMBER	12345	BC6	REVISION
			C01

Tekla Structures

GENERAL NOTES:-
 STANDARD HOLE PUNCHING FOR ALL SECTIONS 18mm DIA
 ALL OUR CLEATS ARE HOT ROLLED STEEL GRADE S355JR
 ALL WELD ON CLEATS ARE SUPPLIED BLACK
 ALL BOLT ON CLEATS CAN BE SUPPLIED BLACK OR GALVANISED TO 85 MICRONS

- - SITE BOLTS
- - SITE C/SUNK NEAR SIDE
- - SITE C/SUNK FAR SIDE

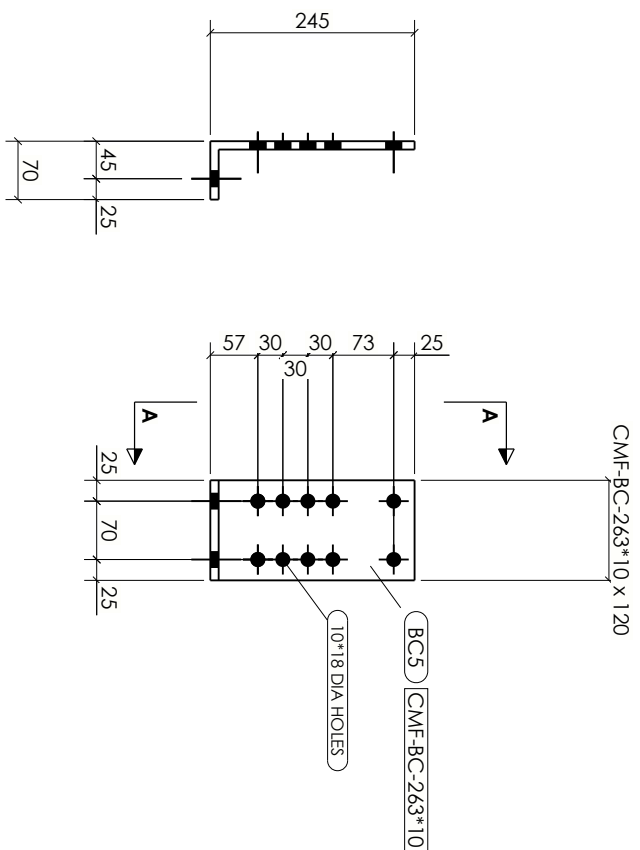

SECTION A - A

CMF PROFILE SIZE:- **CMF-BC-263*10**

ALL DIMENSIONS IN MILLIMETRES - DO NOT SCALE - IF IN DOUBT ASK

PRODUCT TYPE:- **CLEAT**

1 NO. ITEMS REQUIRED MARKED **BC5**



Construction Metal Forming (Head Office)
 Unit 3, Marnlidia Technology Park,
 Old Abergavenny Road, Marnlidia,
 Monmouthshire, NP24 0JJ
 Tel: 01495 261080
 Email: info@cmfuk.com
 Website: www.cmfuk.com





CLIENT:- CMF	PROJECT:- CMF Master Model		
PROJECT ADDRESS:- Construction Metal Forming (Head Office)	COMPONENT NAME:- CMF_CLEAT BOLTED (MBOC-263)		
DRAWN BY:- CMF	DATE:- 23.01.2023	DRAWING NUMBER	SCALE:- 1:7.5
CONTRACT NUMBER	12345	BC5	REVISION
			C01

APPENDIX A - COMPONENT DRAWINGS

CMF CLEATS

Tekla Structures

GENERAL NOTES:-
 STANDARD HOLE PUNCHING FOR ALL SECTIONS, 18mm DIA
 ALL OUR CLEATS ARE HOT ROLLED STEEL GRADE S355JR
 ALL WELD ON CLEATS ARE SUPPLIED BLACK
 ALL BOLT ON CLEATS CAN BE SUPPLIED BLACK OR GALVANISED TO 85 MICRONS

 - SITE BOLTS
 - SITE C/SUNK NEARSIDE
 - SITE C/SUNK FARSIDE

CLIENT: **CMF**
 PROJECT: **CMF Master Model**
 PROJECT ADDRESS: **Construction Metal Forming (Head Office)**
 COMPONENT NAME:- **CMF WELD ON CLEAT P-123 TO P-403 (WOC)**
 DRAWN BY: **CMF** DATE: **27.09.2022** SCALE: **1:5**
 CONTRACT NUMBER **123445** DRAWING NUMBER **F2** REVISION **C01**

Construction Metal Forming (Head Office)
 Unit 3, Mammilad Technology Park,
 Old Abergavenny Road, Mammilad,
 Monmouthshire, NP24 0JJ
 Tel: 01452 61080
 Fax: 01452 61080
 Website: www.cmf.fuk.com

89 No. CLEAT REQUIRED MARKED F2



SECTION SIZE	DIM 'A'	DIM 'B'	DIM 'T'	DIM 'H'
123	53	42	6	120
143	53	52	6	130
173	73	57	6	155
203	103	57	6	185
233	133	57	8	215
263	163	57	8	245
303	203	57	10	285
353	253	57	10	335
403	303	57	10	385

CMF PROFILE SIZE:- **CMF-P-123*6**

ALL DIMENSIONS IN MILLIMETRES - DO NOT SCALE - IF IN DOUBT ASK

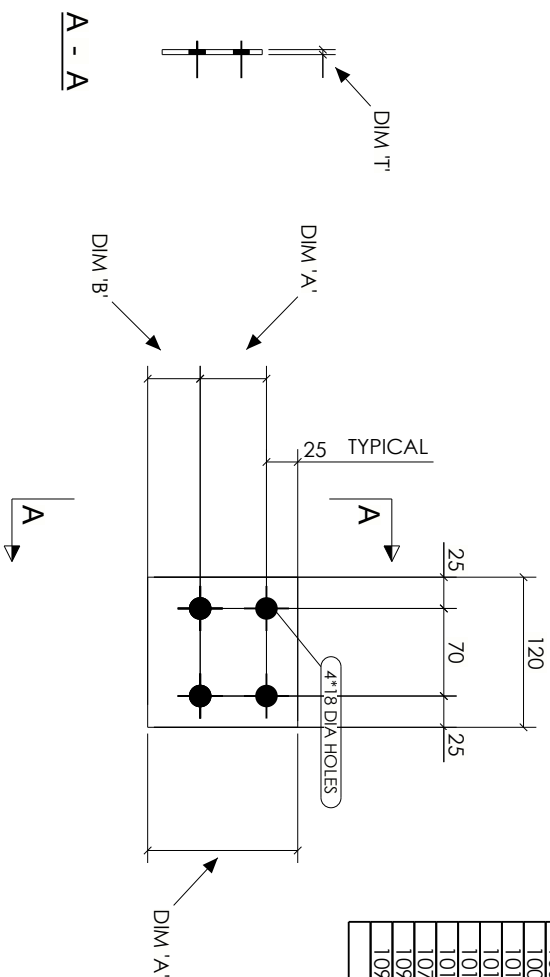

PRODUCT TYPE:- **CLEAT**

ALLOCATION TO ASSEMBLIES	
Assembly Mark	TOTAL
1005	1
1006	1
1009	1
1015	14
1016	14
1017	7
1018	7
1072	42
1090	1
1094	1
TOTAL	89



Tekla Structures

GENERAL NOTES:-
 STANDARD HOLE PUNCHING FOR ALL SECTIONS, 18mm DIA
 ALL OUR CLEATS ARE HOT ROLLED STEEL GRADE S355JR
 ALL WELD ON CLEATS ARE SUPPLIED BLACK
 ALL BOLT ON CLEATS CAN BE SUPPLIED BLACK OR GALVANISED TO 85 MICRONS

 - SITE BOLTS
 - SITE C/SUNK NEARSIDE
 - SITE C/SUNK FARSIDE

CLIENT: **CMF**
 PROJECT: **CMF Master Model**
 PROJECT ADDRESS: **Construction Metal Forming (Head Office)**
 COMPONENT NAME:- **CMF WELD ON CLEAT P-203*6 (MWOC)**
 DRAWN BY: **CMF** DATE: **18.01.2023** SCALE: **1:5**
 CONTRACT NUMBER **123445** DRAWING NUMBER **F4** REVISION **C01**

Construction Metal Forming (Head Office)
 Unit 3, Mammilad Technology Park,
 Old Abergavenny Road, Mammilad,
 Monmouthshire, NP24 0JJ
 Tel: 01452 61080
 Fax: 01452 61080
 Website: www.cmf.fuk.com

86 No. CLEAT REQUIRED MARKED F4



ALLOCATION TO ASSEMBLIES	
Assembly Mark	TOTAL
1005	1
1006	1
1023	7
1024	7
1025	6
1026	7
1074	42
1090	1
1094	1
1097	6
1098	7
TOTAL	86

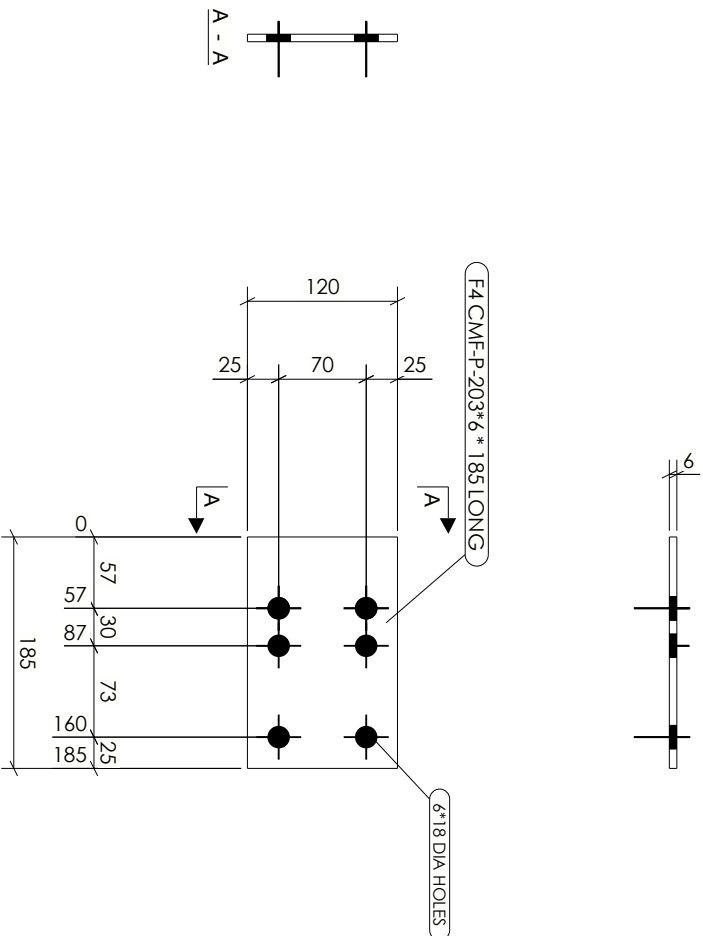

APPENDIX A - COMPONENT DRAWINGS

CMF CLEATS

Tekla Structures

GENERAL NOTES:-
 STANDARD HOLE PUNCHING FOR ALL SECTIONS, 18mm DIA
 ALL OUR CLEATS ARE HOT ROLLED STEEL GRADE S355JR
 ALL WELD ON CLEATS ARE SUPPLIED BLACK
 ALL BOLT ON CLEATS CAN BE SUPPLIED BLACK OR GALVANISED TO 85 MICRONS

- - SITE BOLTS
- - SITE C/SUNK NEAR SIDE
- - SITE C/SUNK FAR SIDE

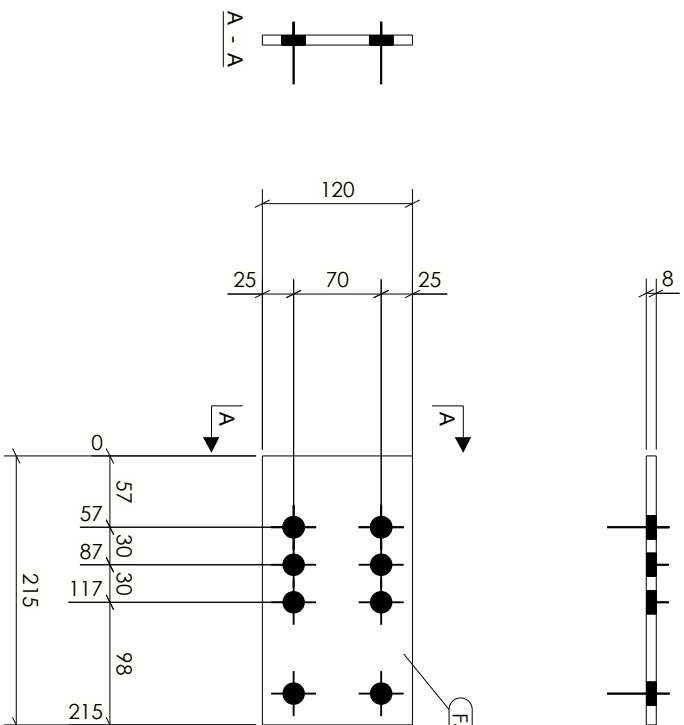

F5 CMF-P-233*8*215 LONG

ALLOCATION TO ASSEMBLIES	
Assembly Mark	TOTAL
1005	1
1006	1
1027	7
1028	7
1029	7
1030	7
1075	42
1090	1
1092	6
1093	6
1094	1
TOTAL	86

CMF PROFILE SIZE:- **CMF-P-233*8**

ALL DIMENSIONS IN MILLIMETRES - DO NOT SCALE - IF IN DOUBT ASK

PRODUCT TYPE:- **CLEAT**

86 No. CLEAT REQUIRED MARKED F5



Construction Metal Forming (Head Office)
 Unit 3, Mammilad Technology Park,
 Old Abergavenny Road, Mammilad,
 Monmouthshire, NP24 0JJ
 Tel: 01452 61080
 Fax: 01452 61080
 Email: info@cmf.co.uk
 Website: www.cmf.co.uk



CLIENT:	CMF
PROJECT:	CMF Master Model
PROJECT ADDRESS:	Construction Metal Forming (Head Office)
COMPONENT NAME:	CMF WELD ON CLEAT P-233*8 (MWOC)
DRAWN BY:	CMF
DATE:	27.09.2022
CONTRACT NUMBER:	12345
DRAWING NUMBER:	F5
SCALE:	1:5
REVISION:	C01

Tekla Structures

GENERAL NOTES:-
 STANDARD HOLE PUNCHING FOR ALL SECTIONS, 18mm DIA
 ALL OUR CLEATS ARE HOT ROLLED STEEL GRADE S355JR
 ALL WELD ON CLEATS ARE SUPPLIED BLACK
 ALL BOLT ON CLEATS CAN BE SUPPLIED BLACK OR GALVANISED TO 85 MICRONS

- - SITE BOLTS
- - SITE C/SUNK NEAR SIDE
- - SITE C/SUNK FAR SIDE

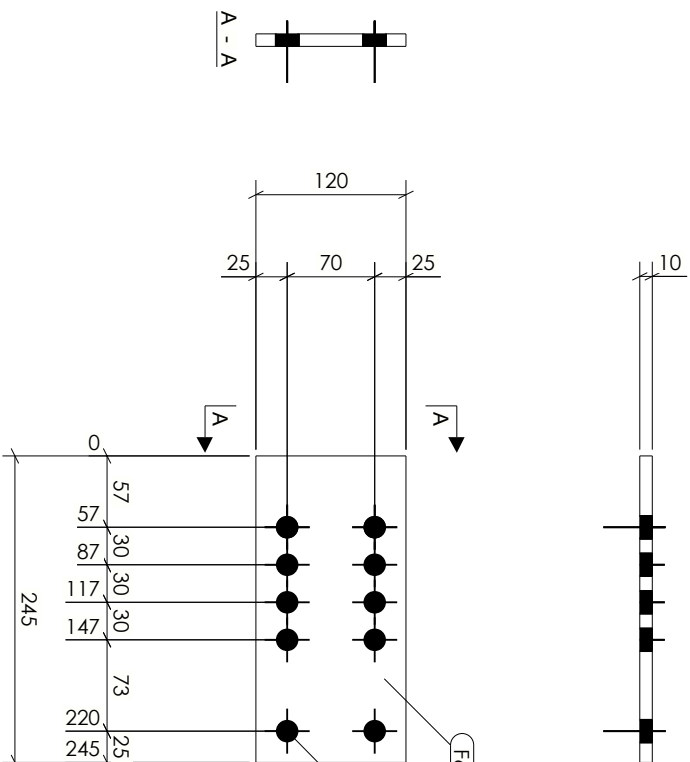

F6 CMF-P-263*10*245 LONG

ALLOCATION TO ASSEMBLIES	
Assembly Mark	TOTAL
1005	1
1006	1
1031	14
1032	14
1033	7
1034	7
1076	42
1090	1
1094	1
TOTAL	88

88 No. CLEAT REQUIRED MARKED F6



Construction Metal Forming (Head Office)
 Unit 3, Mammilad Technology Park,
 Old Abergavenny Road, Mammilad,
 Monmouthshire, NP24 0JJ
 Tel: 01452 61080
 Fax: 01452 61080
 Email: info@cmf.co.uk
 Website: www.cmf.co.uk



CLIENT:	CMF
PROJECT:	CMF Master Model
PROJECT ADDRESS:	Construction Metal Forming (Head Office)
COMPONENT NAME:	CMF WELD ON CLEAT P-263*8 (MWOC)
DRAWN BY:	CMF
DATE:	27.09.2022
CONTRACT NUMBER:	12345
DRAWING NUMBER:	F6
SCALE:	1:5
REVISION:	C01

CMF PROFILE SIZE:- **CMF-P-263*10**

ALL DIMENSIONS IN MILLIMETRES - DO NOT SCALE - IF IN DOUBT ASK

PRODUCT TYPE:- **CLEAT**

APPENDIX A - COMPONENT DRAWINGS

CMF CLEATS

CMF PROFILE SIZE:- CMF-WC203	ALL DIMENSIONS IN MILLIMETRES - DO NOT SCALE - IF IN DOUBT ASK	PRODUCT TYPE:- CLEAT
-------------------------------------	--	-----------------------------

ALLOCATION TO ASSEMBLIES	
Assembly Mark	TOTAL
1007	3
1009	1
1025	1
1097	1
TOTAL	6

GENERAL NOTES:-
 STANDARD HOLE PUNCHING FOR ALL SECTIONS, 18mm DIA
 ALL OUR CLEATS ARE HOT ROLLED STEEL GRADE S355JR
 ALL WELD ON CLEATS ARE SUPPLIED BLACK
 ALL BOLT ON CLEATS CAN BE SUPPLIED BLACK OR GALVANISED TO 85 MICRONS

CMF PROFILE SIZE:- CMF-WC173	ALL DIMENSIONS IN MILLIMETRES - DO NOT SCALE - IF IN DOUBT ASK	PRODUCT TYPE:- CLEAT
-------------------------------------	--	-----------------------------

ALLOCATION TO ASSEMBLIES	
Assembly Mark	TOTAL
1007	3
1009	1
1093	1
1095	1
1096	8
TOTAL	14

GENERAL NOTES:-
 STANDARD HOLE PUNCHING FOR ALL SECTIONS, 18mm DIA
 ALL OUR CLEATS ARE HOT ROLLED STEEL GRADE S355JR
 ALL WELD ON CLEATS ARE SUPPLIED BLACK
 ALL BOLT ON CLEATS CAN BE SUPPLIED BLACK OR GALVANISED TO 85 MICRONS

Tekla Structures

- SITE BOLTS
- SITE C/SUNK NEARSIDE
- SITE C/SUNK FARSIDE

GENERAL NOTES:-
 STANDARD HOLE PUNCHING FOR ALL SECTIONS, 18mm DIA
 ALL OUR CLEATS ARE HOT ROLLED STEEL GRADE S355JR
 ALL WELD ON CLEATS ARE SUPPLIED BLACK
 ALL BOLT ON CLEATS CAN BE SUPPLIED BLACK OR GALVANISED TO 85 MICRONS

CLIENT: **CMF**
 PROJECT: **CMF Master Model**
 PROJECT ADDRESS: **Construction Metal Forming (Head Office)**
 COMPONENT NAME:- **CMF WELD ON CLEAT PSC-173 (WOC)**
 DRAWN BY: **CMF** DATE: **23.01.2023** SCALE: **1:3.3**
 CONTRACT NUMBER **12345** DRAWING NUMBER **F110** REVISION **C01**

14 No. CLEAT REQUIRED MARKED F110

APPENDIX A - COMPONENT DRAWINGS

CMF CLEATS

Tekla Structures

GENERAL NOTES:-
 STANDARD HOLE PUNCHING FOR ALL SECTIONS, 18mm DIA
 ALL OUR CLEATS ARE HOT ROLLED STEEL GRADE S355JR
 ALL WELD ON CLEATS ARE SUPPLIED BLACK
 ALL BOLT ON CLEATS CAN BE SUPPLIED BLACK OR GALVANISED TO 85 MICRONS

- - SITE BOLTS
- - SITE C/SUNK NEARSIDE
- - SITE C/SUNK FARSIDE

Construction Metal Forming (Head Office)
 Unit 3, Mammilad Technology Park,
 Old Aberqeenry Road, Mammilad,
 Monmouthshire, NP4 0JJ
 Tel: 01452 61080
 Fax: 01452 61080
 Website: www.cmf.uk.com



4 NO. CLEAT REQUIRED MARKED F20



CLIENT:	CMF
PROJECT:	CMF Master Model
PROJECT ADDRESS:	Construction Metal Forming (Head Office)
COMPONENT NAME:	CMF WELD ON CLEAT PSC-233 (WOC)
DRAWN BY:	CMF
DATE:	23.01.2023
CONTRACT NUMBER	12345
DRAWING NUMBER	F20
SCALE:	1:3.3
REVISION	C01

CMF PROFILE SIZE:- **CMF-WC233** | ALL DIMENSIONS IN MILLIMETRES - DO NOT SCALE - IF IN DOUBT ASK | PRODUCT TYPE:- **CLEAT**

ALLOCATION TO ASSEMBLIES	
Assembly Mark	TOTAL
1007	3
1009	1
TOTAL	4

Tekla Structures

GENERAL NOTES:-
 STANDARD HOLE PUNCHING FOR ALL SECTIONS, 18mm DIA
 ALL OUR CLEATS ARE HOT ROLLED STEEL GRADE S355JR
 ALL WELD ON CLEATS ARE SUPPLIED BLACK
 ALL BOLT ON CLEATS CAN BE SUPPLIED BLACK OR GALVANISED TO 85 MICRONS

- - SITE BOLTS
- - SITE C/SUNK NEARSIDE
- - SITE C/SUNK FARSIDE

Construction Metal Forming (Head Office)
 Unit 3, Mammilad Technology Park,
 Old Aberqeenry Road, Mammilad,
 Monmouthshire, NP4 0JJ
 Tel: 01452 61080
 Fax: 01452 61080
 Website: www.cmf.uk.com



4 NO. CLEAT REQUIRED MARKED F19



CLIENT:	CMF
PROJECT:	CMF Master Model
PROJECT ADDRESS:	Construction Metal Forming (Head Office)
COMPONENT NAME:	CMF WELD ON CLEAT PSC-263 (WOC)
DRAWN BY:	CMF
DATE:	23.01.2023
CONTRACT NUMBER	12345
DRAWING NUMBER	F19
SCALE:	1:3.3
REVISION	C01

CMF PROFILE SIZE:- **CMF-WC263** | ALL DIMENSIONS IN MILLIMETRES - DO NOT SCALE - IF IN DOUBT ASK | PRODUCT TYPE:- **CLEAT**

ALLOCATION TO ASSEMBLIES	
Assembly Mark	TOTAL
1007	3
1009	1
TOTAL	4

APPENDIX A - COMPONENT DRAWINGS

CMF ACCESSORIES

Tekla Structures

<ul style="list-style-type: none"> ● - SITE BOLTS ● - SITE C/SUNK NEAR SIDE ● - SITE C/SUNK FAR SIDE 	
---	--

GENERAL NOTES:-
 STANDARD HOLE PUNCHING FOR ALL SECTIONS, 18mm DIA
 ALL OUR SECTIONS ARE COLD FORMED FROM HOT DIPPED Z275
 GALVANISED S450GD STEEL TO BS EN 10346:2015 AND
 BS EN 10143:2006 WITH A MINIMUM YIELD STRENGTH OF 450N/mm²

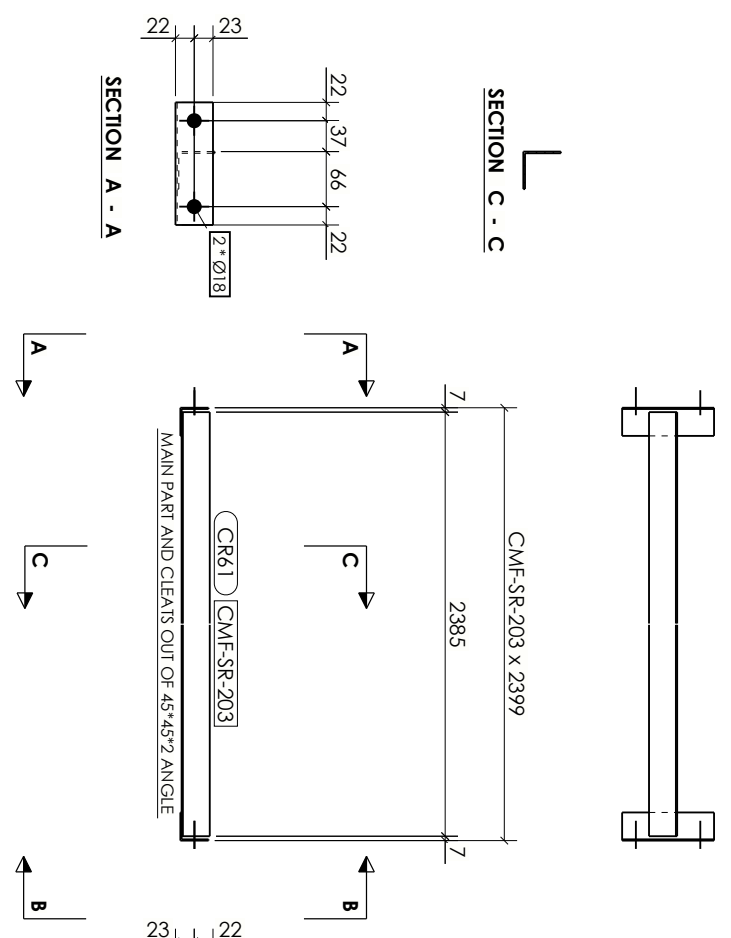

24 NO. ITEMS REQUIRED MARKED CR61



Construction Metal Forming (Head Office)
 Unit 3, Marnlied Technology Park,
 Old Abergoenny Road, Marnlied,
 Monrovia, N/A 4 011
 Tel: 01 493 61080
 Email: info@cmfuk.com
 Website: www.cmfuk.com



CLIENT: CMF	PROJECT: CMF Master Model
PROJECT ADDRESS: Construction Metal Forming (Head Office)	COMPONENT NAME: CMF_STRUT
DRAWN BY: CMF	DATE: 06.01.2023
CONTRACT NUMBER: 12345	DRAWING NUMBER: CR61
	SCALE: 1:10
	REVISION: C01

CMF PROFILE SIZE:- **CMF-SR-203** ALL DIMENSIONS IN MILLIMETRES - DO NOT SCALE - IF IN DOUBT ASK PRODUCT TYPE:- **STRUT**

Tekla Structures

<ul style="list-style-type: none"> ● - SITE BOLTS ● - SITE C/SUNK NEAR SIDE ● - SITE C/SUNK FAR SIDE 	
---	--

GENERAL NOTES:-
 STANDARD HOLE PUNCHING FOR ALL SECTIONS, 18mm DIA
 ALL OUR SECTIONS ARE COLD FORMED FROM HOT DIPPED Z275
 GALVANISED S450GD STEEL TO BS EN 10346:2015 AND
 BS EN 10143:2006 WITH A MINIMUM YIELD STRENGTH OF 450N/mm²

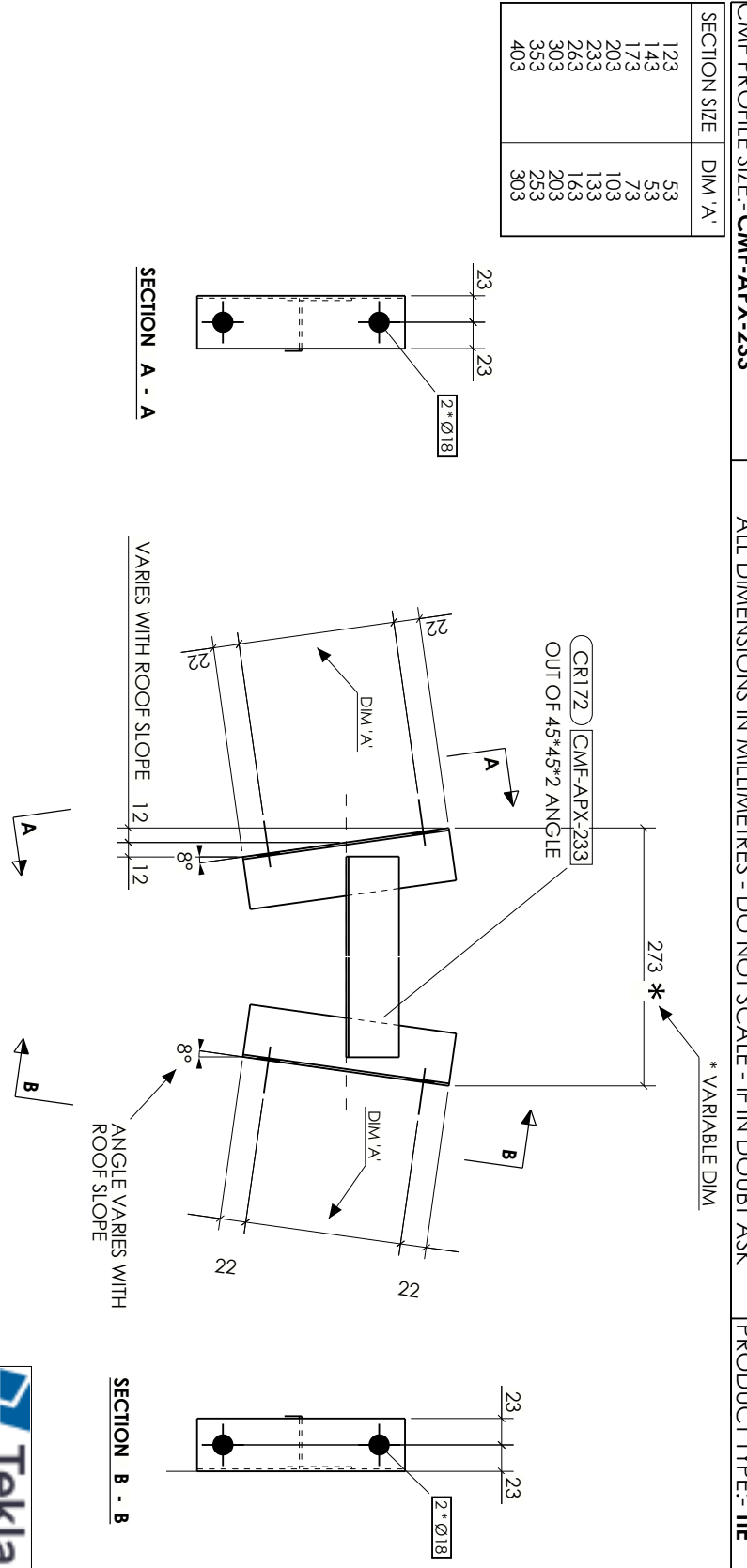

10 NO. ITEMS REQUIRED MARKED CR172



Construction Metal Forming (Head Office)
 Unit 3, Marnlied Technology Park,
 Old Abergoenny Road, Marnlied,
 Monrovia, N/A 4 011
 Tel: 01 493 61080
 Email: info@cmfuk.com
 Website: www.cmfuk.com



CLIENT: CMF	PROJECT: CMF Master Model
PROJECT ADDRESS: Construction Metal Forming (Head Office)	COMPONENT NAME: CMF_APEX_STRUT
DRAWN BY: CMF	DATE: 06.01.2023
CONTRACT NUMBER: 12345	DRAWING NUMBER: CR172
	SCALE: 1:5
	REVISION: C01

CMF PROFILE SIZE:- **CMF-APX-233** ALL DIMENSIONS IN MILLIMETRES - DO NOT SCALE - IF IN DOUBT ASK PRODUCT TYPE:- **TIE**

SECTION SIZE	DIM 'A'
123	53
143	53
173	73
203	103
233	133
263	163
303	203
353	253
403	303

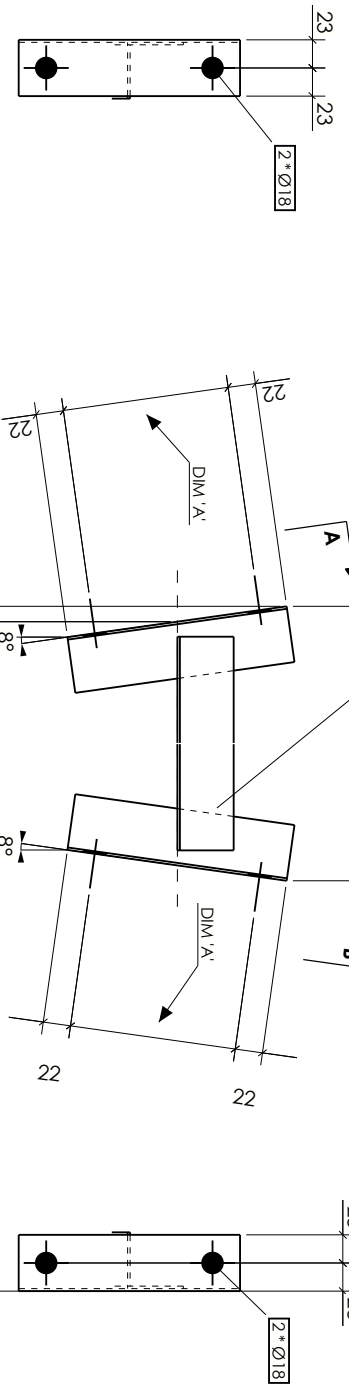

APPENDIX A - COMPONENT DRAWINGS

CMF ACCESSORIES

Tekla Structures

<p>GENERAL NOTES:- STANDARD HOLE PUNCHING FOR ALL SECTIONS 18mm DIA ALL OUR SECTIONS ARE COLD FORMED FROM HOT DIPPED Z275 GALVANISED S450GD STEEL TO BS EN 10346:2015 AND BS EN 10143:2006 WITH A MINIMUM YIELD STRENGTH OF 450N/mm²</p>	<ul style="list-style-type: none"> ● - SITE BOLTS ● - SITE C/SUNK NEARSIDE ● - SITE C/SUNK FARSIDE
---	---

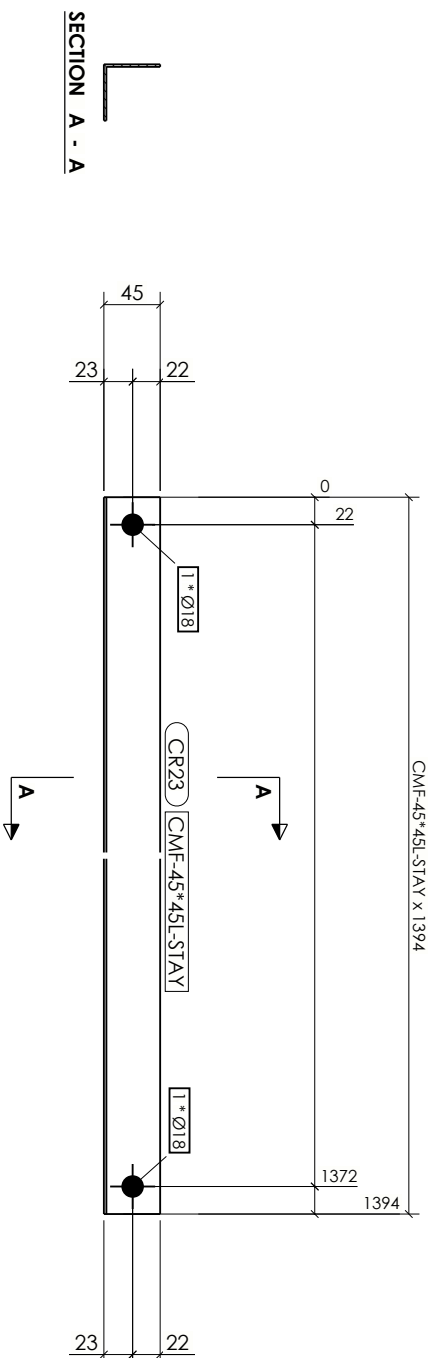

2 NO. ITEMS REQUIRED MARKED **CR23**



Construction Metal Forming (Head Office)
Unit 3, Marnlied Technology Park,
Old Abergoenny Road, Marnlied,
Morriston, Cardiff, NP24 0JJ
Tel: 01 493 61080
Email: info@cmfuk.com
Website: www.cmfuk.com

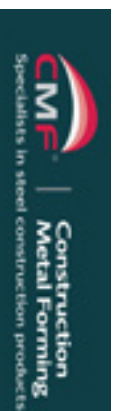

CLIENT:	CMF
PROJECT:	CMF Master Model
PROJECT ADDRESS:	Construction Metal Forming (Head Office)
COMPONENT NAME:-	CMF_STAY (45*45*2)
DRAWN BY:	CMF
DATE:	13.12.2022
CONTRACT NUMBER	12345
DRAWING NUMBER	CR23
SCALE:	1:5
REVISION	C01

CMF PROFILE SIZE:- **CMF-45*45L-STAY** ALL DIMENSIONS IN MILLIMETRES - DO NOT SCALE - IF IN DOUBT ASK PRODUCT TYPE:- **STAY**

Tekla Structures

<p>GENERAL NOTES:- STANDARD HOLE PUNCHING FOR ALL SECTIONS 18mm DIA ALL OUR SECTIONS ARE COLD FORMED FROM HOT DIPPED Z275 GALVANISED S450GD STEEL TO BS EN 10346:2015 AND BS EN 10143:2006 WITH A MINIMUM YIELD STRENGTH OF 450N/mm²</p>	<ul style="list-style-type: none"> ● - SITE BOLTS ● - SITE C/SUNK NEARSIDE ● - SITE C/SUNK FARSIDE
---	---

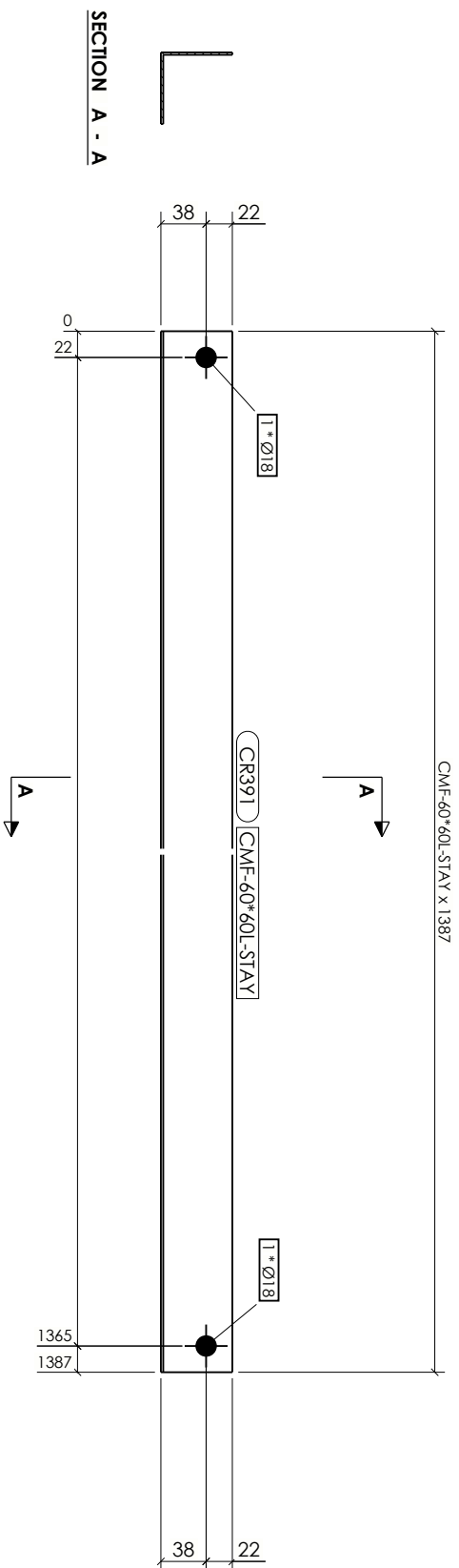

1 NO. ITEMS REQUIRED MARKED **CR391**



Construction Metal Forming (Head Office)
Unit 3, Marnlied Technology Park,
Old Abergoenny Road, Marnlied,
Morriston, Cardiff, NP24 0JJ
Tel: 01 493 61080
Email: info@cmfuk.com
Website: www.cmfuk.com



CLIENT:	CMF
PROJECT:	CMF Master Model
PROJECT ADDRESS:	Construction Metal Forming (Head Office)
COMPONENT NAME:-	CMF_STAY (60*60*2)
DRAWN BY:	CMF
DATE:	26.01.2023
CONTRACT NUMBER	12345
DRAWING NUMBER	CR391
SCALE:	1:5
REVISION	C01

CMF PROFILE SIZE:- **CMF-60*60L-STAY** ALL DIMENSIONS IN MILLIMETRES - DO NOT SCALE - IF IN DOUBT ASK PRODUCT TYPE:- **STAY**

APPENDIX A - COMPONENT DRAWINGS

CMF ACCESSORIES

Tekla Structures

CMF PROFILE SIZE:- CMF-CLEADER-45*45 | ALL DIMENSIONS IN MILLIMETRES - DO NOT SCALE - IF IN DOUBT ASK | PRODUCT TYPE:- CLEADER RAIL

ALL CLEADER RAILS ARE PROVIDED WITHOUT HOLES
 THE MAXIMUM LENGTH IS 4m
 ALL OUR SECTIONS ARE COLD FORMED FROM HOT DIPPED Z275 GALVANISED S450GD STEEL TO BS EN 10346:2015 AND BS EN 10143:2006 WITH A MINIMUM YIELD STRENGTH OF 450N/mm²

GENERAL NOTES:-
 ALL CLEADER RAILS ARE PROVIDED WITHOUT HOLES
 THE MAXIMUM LENGTH IS 4m
 ALL OUR SECTIONS ARE COLD FORMED FROM HOT DIPPED Z275 GALVANISED S450GD STEEL TO BS EN 10346:2015 AND BS EN 10143:2006 WITH A MINIMUM YIELD STRENGTH OF 450N/mm²

- SITE BOLTS
 - SITE C/SUNK NEAR SIDE
 - SITE C/SUNK FAR SIDE

CMF-CLEADER-45 x 45 x 4000

CL1 | CMF-CLEADER-45*45

1 No. ITEMS REQUIRED MARKED **CL1**

Tekla

Construction Metal Forming (Head Office)
 Unit 3, Marnliad Technology Park,
 Old Abergavenny Road, Marnliad,
 Monmouthshire, NP24 0JJ
 Tel: 01495 61080
 Email: info@cmfuk.com
 Website: www.cmfuk.com

CLIENT:- **CMF**
 PROJECT:- **CMF Master Model**
 PROJECT ADDRESS:- **Construction Metal Forming (Head Office)**

COMPONENT NAME:- **CMF_CLEADER**

DRAWN BY:- CMF	DATE:- 25.01.2023	SCALE:- 1:5
CONTRACT NUMBER 12345	DRAWING NUMBER CL1	REVISION C01

Tekla Structures

CMF PROFILE SIZE:- CMF-CLEADER-60*60 | ALL DIMENSIONS IN MILLIMETRES - DO NOT SCALE - IF IN DOUBT ASK | PRODUCT TYPE:- CLEADER RAIL

ALL CLEADER RAILS ARE PROVIDED WITHOUT HOLES
 THE MAXIMUM LENGTH IS 4m
 ALL OUR SECTIONS ARE COLD FORMED FROM HOT DIPPED Z275 GALVANISED S450GD STEEL TO BS EN 10346:2015 AND BS EN 10143:2006 WITH A MINIMUM YIELD STRENGTH OF 450N/mm²

GENERAL NOTES:-
 ALL CLEADER RAILS ARE PROVIDED WITHOUT HOLES
 THE MAXIMUM LENGTH IS 4m
 ALL OUR SECTIONS ARE COLD FORMED FROM HOT DIPPED Z275 GALVANISED S450GD STEEL TO BS EN 10346:2015 AND BS EN 10143:2006 WITH A MINIMUM YIELD STRENGTH OF 450N/mm²

- SITE BOLTS
 - SITE C/SUNK NEAR SIDE
 - SITE C/SUNK FAR SIDE

CMF-CLEADER-60 x 60 x 4000

CL2 | CMF-CLEADER-60*60

1 No. ITEMS REQUIRED MARKED **CL2**

Tekla

Construction Metal Forming (Head Office)
 Unit 3, Marnliad Technology Park,
 Old Abergavenny Road, Marnliad,
 Monmouthshire, NP24 0JJ
 Tel: 01495 61080
 Email: info@cmfuk.com
 Website: www.cmfuk.com

CLIENT:- **CMF**
 PROJECT:- **CMF Master Model**
 PROJECT ADDRESS:- **Construction Metal Forming (Head Office)**

COMPONENT NAME:- **CMF_CLEADER**

DRAWN BY:- CMF	DATE:- 25.01.2023	SCALE:- 1:5
CONTRACT NUMBER 12345	DRAWING NUMBER CL2	REVISION C01

APPENDIX A - COMPONENT DRAWINGS

CMF ACCESSORIES

Tekla Structures

SECTION SIZE	DIM 'A'
123	53
143	73
173	103
203	133
233	163
263	193
303	223
353	253
403	303

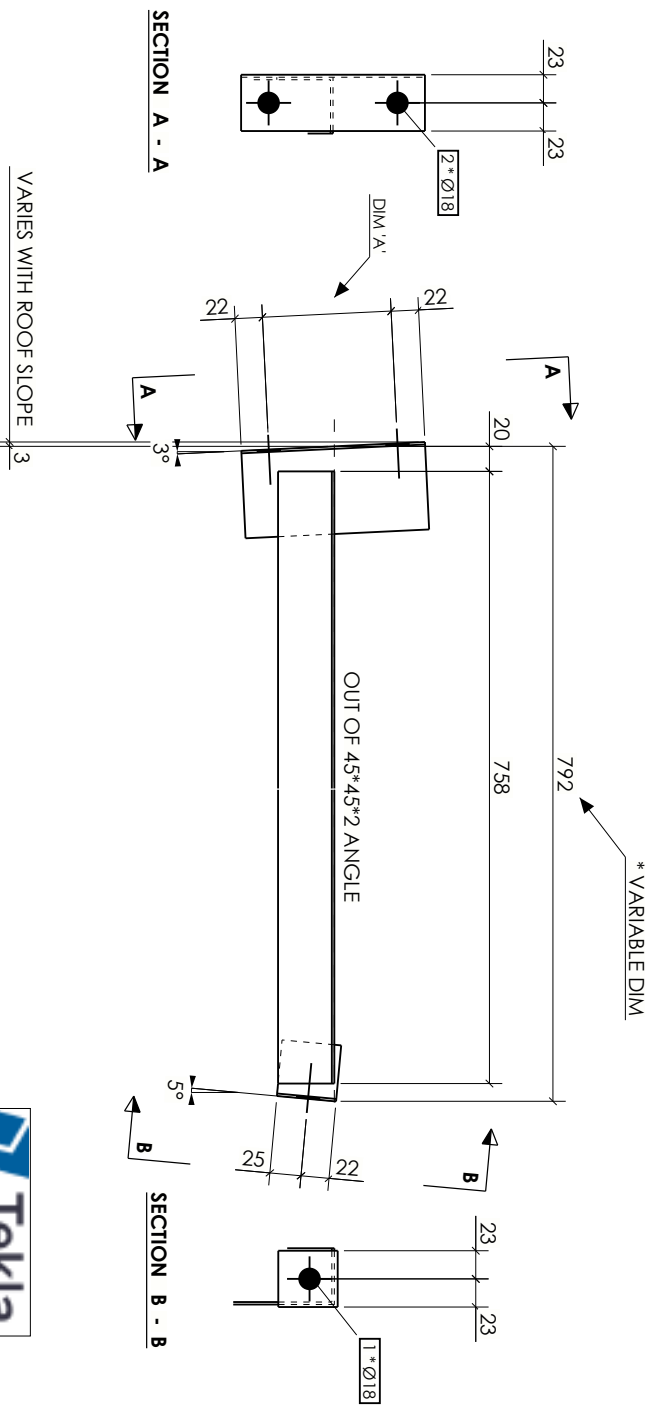

CMF PROFILE SIZE:- **CMF-ES-203**

ALL DIMENSIONS IN MILLIMETRES - DO NOT SCALE - IF IN DOUBT ASK

PRODUCT TYPE:- **EAVES BRACE**

1 NO. ITEMS REQUIRED MARKED **CR247**



GENERAL NOTES:-
STANDARD HOLE PUNCHING FOR ALL SECTIONS 18mm DIA
ALL OUR SECTIONS ARE COLD FORMED FROM HOT DIPPED Z275
GALVANISED S450GD STEEL TO BS EN 10346:2015 AND
BS EN 10143:2006 WITH A MINIMUM YIELD STRENGTH OF 450N/mm²

- - SITE BOLTS
- - SITE C/SUNK NEARSIDE
- - SITE C/SUNK FARSIDE

Construction Metal Forming (Head Office)
Unit 3, Marmida Technology Park,
Old Abercromby Road, Marmilad,
Montrose, Angus, N74 0JJ
Tel: 01492 511080
Email: info@cmfuk.com
Website: www.cmf.uk.com

CLIENT:- **CMF**
PROJECT:- **CMF Master Model**
PROJECT ADDRESS:- **Construction Metal Forming (Head Office)**

COMPONENT NAME:- **CMF_EAVES_BRACE**

DRAWN BY:- CMF	DATE:- 06.01.2023	SCALE:- 1:5
CONTRACT NUMBER	DRAWING NUMBER	REVISION
12345	CR247	C01

Tekla Structures

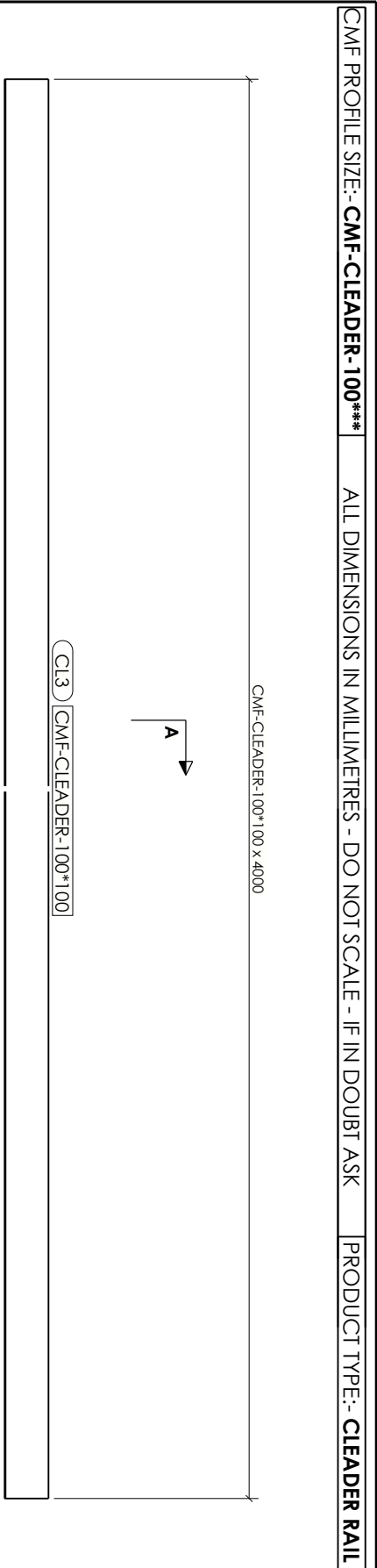

CMF PROFILE SIZE:- **CMF-CLEADER-100*****

ALL DIMENSIONS IN MILLIMETRES - DO NOT SCALE - IF IN DOUBT ASK

PRODUCT TYPE:- **CLEADER RAIL**

1 NO. ITEMS REQUIRED MARKED **CL3**



GENERAL NOTES:-
ALL CLEADER RAILS ARE PROVIDED WITHOUT HOLES
THE MAXIMUM LENGTH IS 4m
ALL OUR SECTIONS ARE COLD FORMED FROM HOT DIPPED Z275
GALVANISED S450GD STEEL TO BS EN 10346:2015 AND
BS EN 10143:2006 WITH A MINIMUM YIELD STRENGTH OF 450N/mm²

- - SITE BOLTS
- - SITE C/SUNK NEARSIDE
- - SITE C/SUNK FARSIDE

Construction Metal Forming (Head Office)
Unit 3, Marmida Technology Park,
Old Abercromby Road, Marmilad,
Montrose, Angus, N74 0JJ
Tel: 01492 511080
Email: info@cmfuk.com
Website: www.cmf.uk.com

CLIENT:- **CMF**
PROJECT:- **CMF Master Model**
PROJECT ADDRESS:- **Construction Metal Forming (Head Office)**

COMPONENT NAME:- **CMF_CLEADER**

DRAWN BY:- CMF	DATE:- 25.01.2023	SCALE:- 1:5
CONTRACT NUMBER	DRAWING NUMBER	REVISION
12345	CL3	C01

APPENDIX A - COMPONENT DRAWINGS

CMF ACCESSORIES

<p>CMF PROFILE SIZE:- CMF-CSR20</p> <p>ALL DIMENSIONS IN MILLIMETRES - DO NOT SCALE - IF IN DOUBT ASK</p> <p>PRODUCT TYPE:- STRUT</p>	<p>SECTION A - A</p> <p>SECTION B - B</p> <p>SECTION C - C</p> <p>4 NO. ITEMS REQUIRED MARKED CR201</p> <p></p> <p>GENERAL NOTES:- STANDARD HOLE PUNCHING FOR ALL SECTIONS, 18mm DIA ALL OUR SECTIONS ARE COLD FORMED FROM HOT DIPPED Z275 GALVANISED S450GD STEEL TO BS EN 10346:2015 AND BS EN 10143:2006 WITH A MINIMUM YIELD STRENGTH OF 450N/mm²</p> <p>CLIENT:- CMF PROJECT:- CMF Master Model PROJECT ADDRESS:- Construction Metal Forming (Head Office) COMPONENT NAME:- CMF CLADDING_SUPPORT_RAIL</p> <p>Construction Metal Forming (Head Office) Unit 3, Marnlied Technology Park, Old Abergavenny Road, Marnlied, Monmouthshire, NP24 0JJ Tel: 01493 61080 Email: info@cmfuk.com Website: www.cmfuk.com</p> <p></p> <p>CLIENT:- CMF PROJECT:- CMF Master Model PROJECT ADDRESS:- Construction Metal Forming (Head Office) COMPONENT NAME:- CMF CLADDING_SUPPORT_RAIL</p> <p>DRAWN BY:- CMF DATE:- 06.01.2023 SCALE:- 1:7.5 CONTRACT NUMBER DRAWING NUMBER REVISION 12345 CR201 C01</p>
---	--

<p>CMF PROFILE SIZE:- CMF-CJR20</p> <p>ALL DIMENSIONS IN MILLIMETRES - DO NOT SCALE - IF IN DOUBT ASK</p> <p>PRODUCT TYPE:- STRUT</p>	<p>SECTION A - A</p> <p>SECTION B - B</p> <p>SECTION C - C</p> <p>3 NO. ITEMS REQUIRED MARKED CR228</p> <p></p> <p>GENERAL NOTES:- STANDARD HOLE PUNCHING FOR ALL SECTIONS, 18mm DIA ALL OUR SECTIONS ARE COLD FORMED FROM HOT DIPPED Z275 GALVANISED S450GD STEEL TO BS EN 10346:2015 AND BS EN 10143:2006 WITH A MINIMUM YIELD STRENGTH OF 450N/mm²</p> <p>CLIENT:- CMF PROJECT:- CMF Master Model PROJECT ADDRESS:- Construction Metal Forming (Head Office) COMPONENT NAME:- CMF CLADDING_JOINT_RAIL</p> <p>Construction Metal Forming (Head Office) Unit 3, Marnlied Technology Park, Old Abergavenny Road, Marnlied, Monmouthshire, NP24 0JJ Tel: 01493 61080 Email: info@cmfuk.com Website: www.cmfuk.com</p> <p></p> <p>CLIENT:- CMF PROJECT:- CMF Master Model PROJECT ADDRESS:- Construction Metal Forming (Head Office) COMPONENT NAME:- CMF CLADDING_JOINT_RAIL</p> <p>DRAWN BY:- CMF DATE:- 27.09.2022 SCALE:- 1:7.5 CONTRACT NUMBER DRAWING NUMBER REVISION 12345 CR228 C01</p>
---	--

MetPurl[®]



**Construction
Metal Forming**

Specialists in steel construction products

Unit 3, Mamhilad Tech. Park,
Old Abergavenny Rd,
Mamhilad, Monmouthshire, NP4 0JJ

Customer services: 01495 761 080

Sales enquiries: 01495 788 936

Technical support: 01495 788 937

e: info@cmf.uk.com

www.cmf.uk.com

Whilst Construction Metal Forming Limited have taken every care to ensure the accuracy of the information, data or advice contained in this brochure, no liability in respect of such information or advice, whether given negligently or not, can be accepted by the company. Construction Metal Forming Limited retain the right to amend the technical specifications of any of its products without prior notice.

Copyright ©2023 Construction Metal Forming Limited. All rights reserved.

No part of this material may be reproduced in any form by any means without the express written permission of Construction Metal Forming Ltd.